

Electromagnetic Transients Program (EMTP)

WORKBOOK

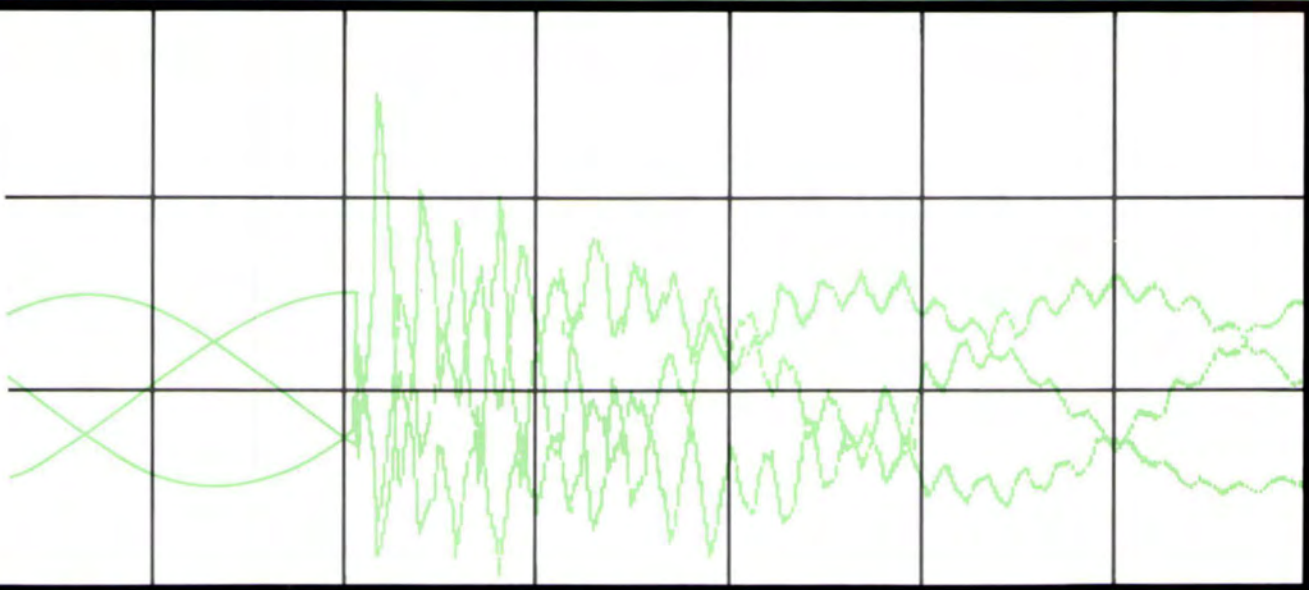

**EMTP DEVELOPMENT COORDINATION GROUP
ELECTRIC POWER RESEARCH INSTITUTE**

R E P O R T S U M M A R Y

SUBJECTS	Power system planning / Transmission: Protection and control	
TOPICS	Transients	Substations
	Computer simulation	Transmission
	Power systems	EMTP code
AUDIENCE	Power system planners / Electrical engineers	

Electromagnetic Transients Program (EMTP) Workbook

High-speed electromagnetic transients are often the controlling factor in transmission system design and operation. This workbook provides case studies for introducing the basics of electromagnetic transient analysis. Sample problems demonstrate analyses of such transients with the EMTP computer code.

BACKGROUND	The electromagnetic transients program (EMTP) is a versatile and efficient computer program that utilities worldwide use for analyzing high-speed power system transients. In response to user needs, EPRI and the EMTP Development Coordination Group—composed of Bonneville Power Administration, the Canadian Electrical Association, Hydro Quebec, Ontario Hydro, the U.S. Bureau of Reclamation, and the Western Area Power Administration—undertook an EMTP enhancement effort. A key part of this effort was the development of a series of program documents ranging from introductory tutorial material to guides for program researchers and experienced EMTP users.
OBJECTIVES	<ul style="list-style-type: none">• To provide utilities with introductory tutorial materials on electromagnetic transients.• To illustrate analysis of such transients with the EMTP computer code.
APPROACH	Focusing on the needs of electrical engineers with no prior experience in analyzing power system transients, the project team designed a small but representative power system model. This model provided a basis for developing case studies to explain electromagnetic transient principles and problems as well as to demonstrate EMTP applications. The workbook was used at three seminars in 1985 and then modified to incorporate the suggestions of seminar participants.
RESULTS	In trial demonstrations at the 1985 seminars, the workbook proved to be an effective means of introducing the fundamentals of analyzing power system transients. Material on such topics as single-phase and multiphase transmission line modeling is presented in detail, without obscuring basic concepts. Progressing slowly from simple to more-complex and more-realistic

analyses, it provides information for beginning EMTP users to analyze power system transients ranging from steady-state phenomena to electromechanical transients and switching surges.

EPRI PERSPECTIVE This workbook provides a practical tool for utilities wishing to build in-house EMTP expertise and to use EMTP for decreasing the cost and increasing the reliability of power system design. The workbook can also be used as a textbook for teaching electromagnetic transient principles at the university level. Intended as an introduction to electromagnetic and electromechanical phenomena, it is designed to dovetail with an EMTP primer (EL-4202) that is now available as well as source code documentation (EL-4652) and an application guide for experienced users (EL-4650) that will be completed later in 1986. Other EPRI reports describing or related to EMTP include EL-3668 and EL-4541.

PROJECT RP2149-6
EPRI Project Manager: J. V. Mitsche
Electrical Systems Division
Contractor: University of Wisconsin at Madison

For further information on EPRI research programs, call
EPRI Technical Information Specialists (415) 855-2411.

Electromagnetic Transients Program (EMTP) Workbook

EL-4651
Research Project 2149-6
Final Report, September 1986

Prepared by

UNIVERSITY OF WISCONSIN AT MADISON
Department of Electrical and Computer Engineering
Madison, Wisconsin 53706

Authors
F. L. Alvarado
R. H. Lasseter
W. F. Long

Prepared for

Electric Power Research Institute
3412 Hillview Avenue
Palo Alto, California 94304

EPRI Project Manager
J. Mitsche

Power System Planning and Operations Program
Electrical Systems Division

ORDERING INFORMATION

Requests for copies of this report should be directed to Research Reports Center (RRC), Box 50490, Palo Alto, CA 94303, (415) 965-4081. There is no charge for reports requested by EPRI member utilities and affiliates, U.S. utility associations, U.S. government agencies (federal, state, and local), media, and foreign organizations with which EPRI has an information exchange agreement. On request, RRC will send a catalog of EPRI reports.

Electric Power Research Institute and EPRI are registered service marks of Electric Power Research Institute, Inc.

Copyright © 1986 Electric Power Research Institute, Inc. All rights reserved.

NOTICE

This report was prepared by the organization(s) named below as an account of work sponsored by the Electric Power Research Institute, Inc. (EPRI). Neither EPRI, members of EPRI, the organization(s) named below, nor any person acting on behalf of any of them: (a) makes any warranty, express or implied, with respect to the use of any information, apparatus, method, or process disclosed in this report or that such use may not infringe privately owned rights; or (b) assumes any liabilities with respect to the use of, or for damages resulting from the use of, any information, apparatus, method, or process disclosed in this report.

Prepared by
University of Wisconsin at Madison
Madison, Wisconsin

ABSTRACT

This workbook represents an elementary introduction to transients in power systems and to the use of the EMTP to study these transients. It covers the following topics: introduction to transients, elementary setup of EMTP simulations, getting data for EMTP studies from load flow and short circuit studies, how extensive and detailed systems should be represented, transmission line representation, simple switching and fault transients, lightning and lightning arresters, transformers. Many examples and problems are included.

CONTENTS OF VOLUME 1

<u>Section</u>	<u>Page</u>
1 SUMMARY	1-1
History of the EMTP	1-2
Subjects Covered	1-2
Expectations	1-4
2 THE 230KV SAMPLE SYSTEM USED IN THIS WORKBOOK	2-1
Load Flow Studies on the Sample System	2-1
Short Circuit Studies on the Sample System	2-7
Transient Problems to be Studied in the Sample System	2-7
3 AN INTRODUCTION TO TRANSIENTS: CLOSING A BREAKER	3-1
Theory of Simple Switching Transients	3-1
EMTP Simulation of Simple Switching Transients	
Trapezoidal Integration	3-5
Preparing a Basic EMTP Input Data Case	3-8
Fixed Point Miscellaneous Data Line	3-9
Integer Miscellaneous Data Line	3-10
Branch Data	3-11
Switch Data	3-13
Source Data	3-14
Node Voltage Output Request Data	3-15
Plot Request Data	3-16
Load Energization Examples and Problems	3-35
Calculation of Load Impedances	3-35
Calculation of the Source Voltage	3-37
Obtaining the Source Impedance	3-37
Examples and Results	3-38
4 BASIC THEORY OF DISTRIBUTED TRANSMISSION LINES	4-1
Short Circuit	4-5
Open Circuit	4-7

<u>Section</u>	<u>Page</u>
5 THE EMTF BASIC DISTRIBUTED LINE MODELS	5-1
6 MULTIPHASE TRANSMISSION LINES	6-1
7 THE CALCULATION OF LINE PARAMETERS	7-1
8 SOURCE REPRESENTATION	8-1
9 TRANSIENTS CAUSED BY FAULTS	9-1
Analytic Calculation of Sustained Overvoltages	9-1
EMTF Studies	9-4
10 TRANSIENT RECOVERY VOLTAGES (TRV)	10-1
Background	10-1
Using the EMTF to Calculate TRV's	10-6
11 NUMERICAL OSCILLATIONS	11-1
12 RECLOSING INTO TRAPPED CHARGE	12-1
Using the EMTF to Study Reclosing into Trapped Charges	12-11
13 CAPACITOR SWITCHING	13-1
14 REPRESENTATION OF LIGHTNING ARRESTERS AND OTHER NONLINEARITIES	14-1
15 REPRESENTATION OF TRANSFORMERS	15-1
Models for Transformers	15-1
Implementing the Transformer Models in the EMTF	15-4
Calculation of Saturation Curves	15-7
Using the Saturation Curves	15-12

ILLUSTRATIONS

<u>Figure</u>	<u>Page</u>
2.1 Sample System General Features	2-2
2.2 Sample System Positive Sequence Per Unit Parameters for Load Flow Study (Shunt PI Susceptances in Parenthesis)	2-3
2.3 Sample Load Flow Results	2-5
2.4 Sample System, Per-Unit Zero Sequence Parameters For Short Circuit Study	2-8
2.5 Obtaining Circuit Diagrams from One Line Diagrams	2-11
2.6 Total Fault Currents for Three Phase (and SLG) Faults at Designated Buses	2-12
3.1 An RL Circuit with a Sine Wave Source	3-1
3.2 Response of RL Circuit	3-3
3.3 EMTP Model of a Resistor	3-5
3.4 EMTP Model of Inductor and Capacitor	3-6
3.5 The Equivalent Conductance Network Used by the EMTP for an RL Circuit	3-7
3.6 Series RLC Branch	3-12
3.7 A Simple Switch	3-13
3.8 Basic Source Types	3-14
3.9 EMTP Solution of Problem in Figure 3.1	3-19
3.10 Energization of Single Phase .95 pf RL Load From Ideal Source	3-23
3.11 Energization of .95 pf Load	3-26
3.12 Energization of Compensated .8 pf Load	3-29
3.13 Energization of a 3-Phase Load	3-32

<u>Figure</u>	<u>Page</u>
4.1 Small Element of a Transmission Line	4-1
4.2 The Function $f_-(x+vt)$ at (i) $t=0$, and (ii) $t=\tau$	4-3
4.3 Resistance Terminated Line	4-3
4.4 Reflection of a Traveling Wave From a Short Circuit	4-5
4.5 (a), (b), and (c) represent the voltage and current as a function of x for three values of t . (d) and (e) represent the current at either end as a function of t .	4-6
4.6 Traveling Waves Initiated by Energizing an Open-Circuited Line	4-7
5.1 The EMTP Model of a Distributed Line	5-2
5.2 Energization of the Positive Sequence 60 Hz the Equivalent of an Open 15 Mile 230 KV Line Using a PI Equivalent Model	5-7
5.3 Energization of the Positive Sequence of an Open 15 Mile Distributed Line From an Ideal 230 KV Source	5-10
5.4 Energization of the Positive Sequence of a Shorted 15 Mile Distributed Line From an Ideal 230 KV Source	5-13
6.1 How the EMTP Deals With the Propagation of Multimodal Waves	6-7
6.2 Energization of all Three Phases of Transposed Line	6-11
6.3 Energization of Phase "a" of Three Phase Distributed Line	6-14
6.4 Energization of Transposed Line Terminated by a Transformer and an RL Load Using Transposed Distributed Line Models	6-17
6.5 Energization of Transposed Line Connected to Compensated Load	6-20
7.1 The Line of Interest	7-4
7.2 EMTP Input to Determine Parameters of Line. Transposition Assumed	7-5
7.3 Selected Output From Line Constants, Transposed Line	7-5
7.4 EMTP Input to Determine Parameters of Line. Untransposed Line. Bundling Option was not Used. Each Conductor in Bundling Specified Separately	7-6
7.5 Selected Output from Line Constants, Untransposed Line	7-7
8.1 The Form of the Thevenin Equivalent	8-5
8.2 Energization of Transposed Line 1-2 from an Ideal Voltage Source. This Model is Inadequate	8-9

<u>Figure</u>	<u>Page</u>
8.3 Energization of Transposed Line 1-2 Using a Thevenin Equivalent at Bus 1. This Model is Marginally Adequate	8-12
8.4 Energization of Transposed Line 1-2 With Line 7-1 Represented in Detail and Thevenin Equivalence at Buses 1 and 7. This Model is Adequate	8-15
9.1 Illustration of Fault Induced Overvoltages	9-1
9.2 The Effect of Grounding on Sustained Fault Overvoltages	9-3
9.3 Calculation of Steady State Fault Overvoltages. Notice that $t_{max} < 0$ and $KSSOUT > 0$	9-5
9.4 Calculation of Transient Fault Overvoltages for a SLG Fault at Bus 2, Phase a	9-8
10.1 A Trivial TRV Example	10-3
10.2 TRV for Fault at Bus 1, Lines 1-7 and 7-12 Represented	10-7
10.3 Numerical Current Chopping can Produce Numerical Oscillations	10-12
11.1 De-Energization of a Pure RL Load. Numerical Oscillation will occur	11-2
11.2 Result of Differentiation of a Step Function	11-6
11.3 Differentiation of a Slower Step Function	11-6
11.4 Percent Error over a Single Time Step versus Normalized Time Step for Trapezoidal Integration with Damping	11-7
11.5 The de-energization of an Inductor can Produce Numerical Oscillations	11-9
12.1 Circuit to Illustrate Reclosing into Trapped Charges	12-3
12.2 Trapping of Charge in a Capacitor	12-4
12.3 Reclosing into Trapped Charge	12-5
12.4 Trapped Charge in a Trivial Circuit. Two Breakers are used to Model Opening and Reclosing	12-8
12.5 Trapping of Charge on Line 1-2 by Opening of Breaker	12-14
12.6 Reclosing into a Trapped Charge on Line 1-2	12-17
12.7 The Effect of 300 Ω Pre-insertion (see problem 12.3)	12-20
13.1 Disconnection of a Three Phase Y-Connected Capacitor Bank. Phase C Opens First, Followed by Phases A and B. TRV is differences Between Voltages.	13-2

<u>Figure</u>	<u>Page</u>
13.2 Same as 13.1, but Breakers for Phase A and B stuck	13-6
13.3 Same as 13.1, but Breaker for Phase B stuck. Notice pu TRV in excess of 3 pu on Phase 3	13-9
14.1 The Variable Characteristic Devices Handled by the EMTP	14-2
14.2 How the EMTP Represents Nonlinearities	14-4
14.3 Nonlinearities may lead to Multiple Solutions	14-5
14.4 Time-Dependent Resistances	14-6
14.5 Two or More Linearities cannot be solved by the EMTP unless they are in Different Subnetworks	14-8
14.6 How to Separate Nonlinearities	14-9
14.7 Reducing a Nonlinear Inductance to a Nonlinear Resistance	14-11
14.8 Energization of Line 1-2 from Ideal Source. Line Terminated in ZnO Arrester	14-13
14.9 Energization of same line, but terminated in a SiC Gapped Arrester	14-16
14.10 Same as 14.9, but using the Pseudo-nonlinear Arrester Model	14-19
14.11 Same, with Gapless SiC Arresters	14-22
15.1 Representation of a Two Winding Transformer for Slow Transients	15-3
15.2 Recursive Conversion of V_{RMS}/I_{RMS} Curve into ψ/i -Curve	15-7
15.3 Calculation of Saturation Curves Using the EMTP	15-14
15.4 Illustration of the Steady State Magnetization Current as the Voltage is stepped from .9 pu to 1.1 pu every two Cycles. Parallel Voltage Sources are Actually in Series, by EMTP Convention	15-15
15.5 Effect of Saturation and Nonlinearities on Voltage Waveforms	15-18

TABLES

<u>Table</u>	<u>Page</u>
2-1 Listing of Common Format Data for Load Flow	2-4
2-2 Listing of Data for Short Circuit Studies	2-9
3-1 EMTP Input Data Structure	3-9

Section 1

SUMMARY

The objective of this workbook is to provide basic information on the use of the Electromagnetic Transients Program (EMTP). The intent is that a new user may be introduced to the proper application of the EMTP. Power system transients cover range from slow steady state phenomena to electromechanical transients, switching surges, and lightning phenomena. The EMTP can, within certain limitations, study all these.

This workbook is prepared for use in a three-day introductory seminar entitled "Introduction to the ElectroMagnetic Transients Program (EMTP)," sponsored by the Electric Power Research Institute (EPRI). The workbook can be used together with other EPRI documentation to develop increasing knowledge of the EMTP and transients in power systems. The other documentation and approximate dates of availability are:

EMTP Primer	(September 1985)
EMTP Rule Book	(January 1986)
EMTP Theory Book	(September 1986)
EMTP Application Guide	(1987)
EMTP Source Code Documentation	(1987)
EMTP Model Verification	(1987).

Other information on the EMTP may be found in the EMTP Newsletter, IEE/PES Transactions, and in IEEE publication 81EH-173-5-PIMR, the text for a tutorial course "Digital Simulation of Electrical Transient Phenomena."

History of the EMTP

The EMTP was originally developed in the late 1960's by Dr. Hermann Dommel, who brought the program to the Bonneville Power Administration (BPA). They considered the program to be the digital computer replacement for the transient network analyzer (TNA), and expanded it accordingly. Many program improvements have been made by BPA; others have been contributed by utilities and universities. The code has grown by more than an order of magnitude since its early years.

In the last 1970's it was realized that two major shortcomings existed. First, there was no means of educating users; second a broader base of support for program development and distribution was needed. The University of Wisconsin responded to the education need by offering a summer short course on the use of the EMTP. This course continued to be offered, now as an advanced seminar for experienced users.

The program development activity began to move beyond BPA in 1982 with the formation of the EMTP Development Coordination Group. EPRI's participation was formalized in 1983. An improved EMTP will be distributed by EPRI together with the documentation referred to previously. EPRI also has accepted responsibility for the education and training of EMTP users. This workbook and associated seminar, developed by the University of Wisconsin-Madison, are part of that activity.

Subjects Covered

This workbook is intended for use by electric utility engineers. No prior experience with EMTP is assumed. Readers are expected to have an understanding of basic power systems and simple electromagnetic and electromechanical phenomena as would be taught in an undergraduate electrical engineering curriculum.

This workbook is strongly directed toward introductory material, new users, and practical EMTP application. The material is designed to slowly build from simple to more complex and realistic analyses. Thus, readers will receive enough preparation so that EMTP can be used and sophistication can increase with

experience.

The following topics are covered:

- Introduction to transients - the sources of transient phenomena on power systems and means of solution. Lumped parameter circuits, sources.
- Transmission lines - means of modeling single phase and multiphase transmission lines. Traveling wave representation, time delays, attenuation, coupling.
- Switching and fault transients - faults, switching surges, breaker operation, transient recovery voltages.
- Transformer modeling - linear and nonlinear characteristics, loss elements, single phase and multiphase representation, overvoltages, ferroresonance.
- Lightning and arresters - lightning characteristics, SiC and ZnO nonlinear arrester models, insulation coordination, arrester application, voltage and energy considerations.

The material is organized into 15 sections.

Expected Uses of this Workbook

Each of the following sections covers a description of the problem, how to obtain data, an analysis of base case variations, and EMTP input data preparation. Using this workbook as a starting point, other EMTP documentation can be used to increase knowledge of the program, its capabilities, and applying it in more complex studies. In addition to knowledge of the program, however, an understanding of power system transient phenomena is needed before sufficient expertise can be claimed. There is no substitute for fundamental understanding of why a phenomenon exists, and what its effects are expected to be.

Section 2

THE 230KV SAMPLE SYSTEM USED IN THIS WORKBOOK

Most of the case studies in this workbook are based on a 230 KV sample power system designed to illustrate a wide range of transient problems. The intent of this single system approach is to:

- Provide a unified background against which all problems of interest are highlighted.
- Illustrate the way in which you may approach a comprehensive assessment of potential transient problems in your system.
- Show how to make the transition from a steady state power flow/short circuit data base to an EMTF data base.

The sample system is illustrated in Figure 2.1. The scenario provided is one where most of the system generation is toward the left, most load toward the right. The studies are centered around bus 1. Note that bus 1 has the following features:

- Some local generation
- Shunt capacitance, necessary when the generation is out of service.
- Both long and short lines connected to it.

Load flow studies on the sample system

A number of power flow runs have been performed to ascertain the reasonableness of the system. Loadflow data is illustrated in Figure 2.2 and loadflow results for several runs are illustrated in Figure 2.3. These include:

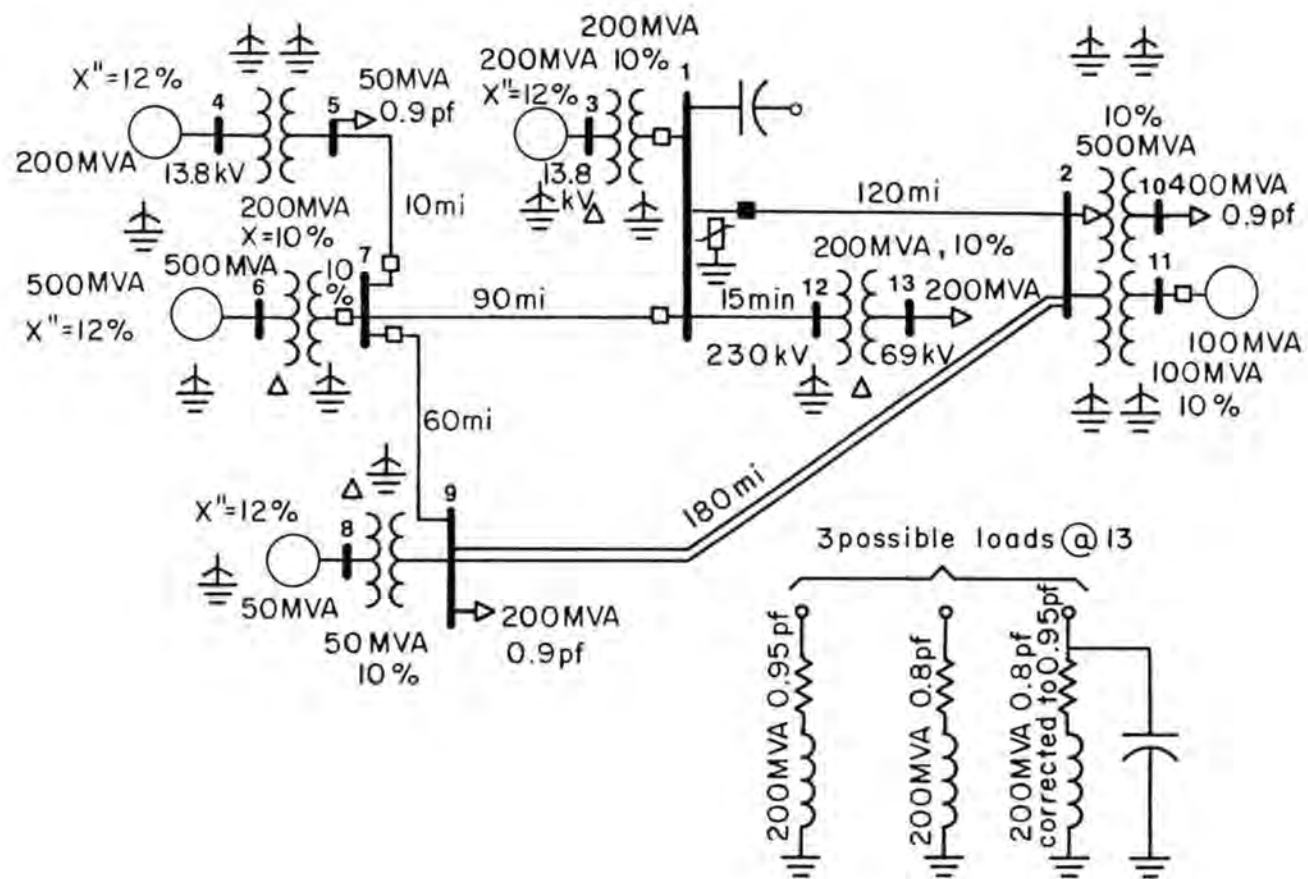

Figure 2.1: Sample system general features.

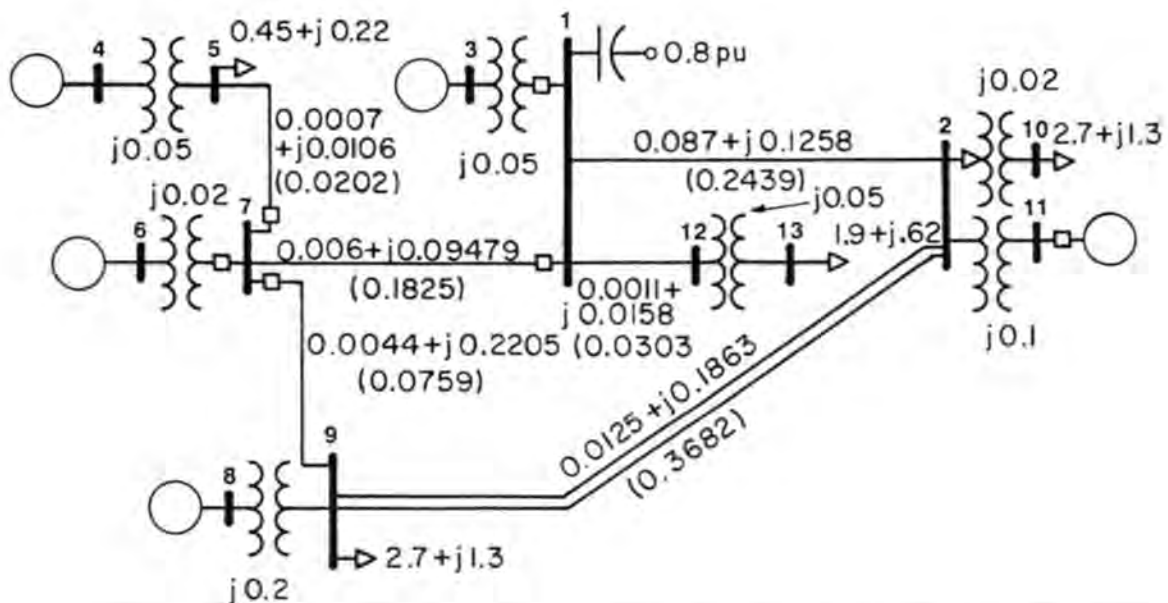

Figure 2.2: Sample system positive sequence per unit parameters for load flow study. (Shunt PI susceptances in parenthesis).

TABLE 2-1

Listing of Common Format Data for Load Flow

BUS DATA FOLLOWS

1	BUS1	0	0	0	1.0324	-9.471	0.0	0.0	0.0	0.0	230.00	0.0000	0.0	0.0	0.0	0.8000027239	
2	BUS2	0	0	0	0.9941	-18.862	0.0	0.0	0.0	0.0	230.00	0.0000	0.0	0.0	0.0	0.027239	
3	GEN3	0	0	2	1.0500	-4.178	0.0	0.0	200.0000	46.1127	13.80	1.0500	9999.00	-9999.0	0.0	0.0	3
4	GEN4	0	0	2	1.0500	3.172	0.0	0.0	200.0000	42.4693	13.80	1.0500	9999.00	-9999.0	0.0	0.0	4
5	BUS5	0	0	0	1.0342	-2.112	45.00000	21.79000	0.0	0.0	230.00	0.0000	0.0	0.0	0.0	0.0	4
6	BUS6	0	0	3	1.0500	0.000	0.0	0.0	283.1200	96.8722	13.80	1.0500	9999.00	-9999.0	0.0	0.0	6
7	BUS7	0	0	0	1.0330	-2.993	0.0	0.0	0.0	0.0	230.00	0.0000	0.0	0.0	0.0	0.0	6
8	GEN8	0	0	2	1.0500	-8.418	0.0	0.0	50.00000	40.9326	13.80	1.0500	9999.00	-9999.0	0.0	0.0	8
9	BUS9	0	0	0	0.9767	-14.013	270.0000	130.7700	0.0	0.0	230.00	0.0000	0.0	0.0	0.0	0.0	8
10	BUS10	0	0	0	0.9786	-22.044	270.0000	130.7625	0.0	0.0	13.80	0.0000	0.0	0.0	0.0	0.65000	8
11	GEN11	0	0	2	1.0500	-16.116	0.0	0.0	50.00000	59.8891	13.80	1.0500	9999.00	-9999.0	0.0	0.0	11
12	BUS12	0	0	0	1.0173	-11.060	0.0	0.0	0.0	0.0	230.00	0.0000	0.0	0.0	0.0	0.0	11
13	BUS13	0	0	0	0.9809	-16.523	190.0000	62.45000	0.0	0.0	69.00	0.0000	0.0	0.0	0.0	0.0	11

-999

BRANCH DATA FOLLOWS

1	2	0	0	1	0	0.0087000	0.1258000	0.2439000	9999	9999	0	0	0	1.0000	0.00	0.0	0.0	0.0	0.0	0.0
2	9	0	0	1	0	0.0127000	0.1863000	0.3682000	9999	9999	0	0	0	1.0000	0.00	0.0	0.0	0.0	0.0	0.0
9	7	0	0	1	0	0.0044000	0.0634000	0.1215000	9999	9999	0	0	0	1.0000	0.00	0.0	0.0	0.0	0.0	0.0
1	7	0	0	1	0	0.0086000	0.0947900	0.1825000	9999	9999	0	0	0	1.0000	0.00	0.0	0.0	0.0	0.0	0.0
5	7	0	0	1	0	0.0007000	0.0106000	0.0202000	9999	9999	0	0	0	1.0000	0.00	0.0	0.0	0.0	0.0	0.0
1	12	0	0	1	0	0.0011000	0.0158000	0.0303000	9999	9999	0	0	0	1.0000	0.00	0.0	0.0	0.0	0.0	0.0
5	4	0	0	1	1	0.0	0.0500000	0.0	9999	9999	0	0	0	1.0000	0.00	0.0	0.0	0.0	0.0	0.0
7	6	0	0	1	1	0.0	0.0200000	0.0	9999	9999	0	0	0	1.0000	0.00	0.0	0.0	0.0	0.0	0.0
9	8	0	0	1	1	0.0	0.2000000	0.0	9999	9999	0	0	0	1.0000	0.00	0.0	0.0	0.0	0.0	0.0
1	3	0	0	1	1	0.0	0.0500000	0.0	9999	9999	0	0	0	1.0000	0.00	0.0	0.0	0.0	0.0	0.0
2	10	0	0	1	1	0.0	0.0200000	0.0	9999	9999	0	0	0	1.0000	0.00	0.0	0.0	0.0	0.0	0.0
2	11	0	0	1	1	0.0	0.1000000	0.0	9999	9999	0	0	0	1.0000	0.00	0.0	0.0	0.0	0.0	0.0
12	13	0	0	1	1	0.0	0.0500000	0.0	9999	9999	0	0	0	1.0000	0.00	0.0	0.0	0.0	0.0	0.0
9	2	0	0	2	0	0.0127000	0.1863000	0.3682000	9999	9999	0	0	0	1.0000	0.00	0.0	0.0	0.0	0.0	0.0

-999

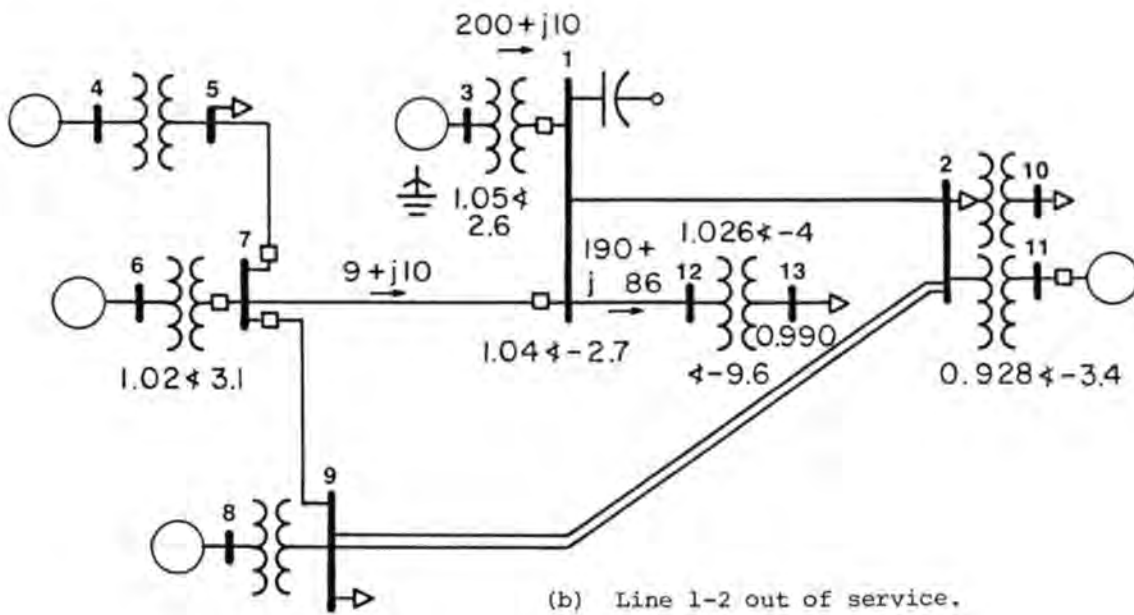
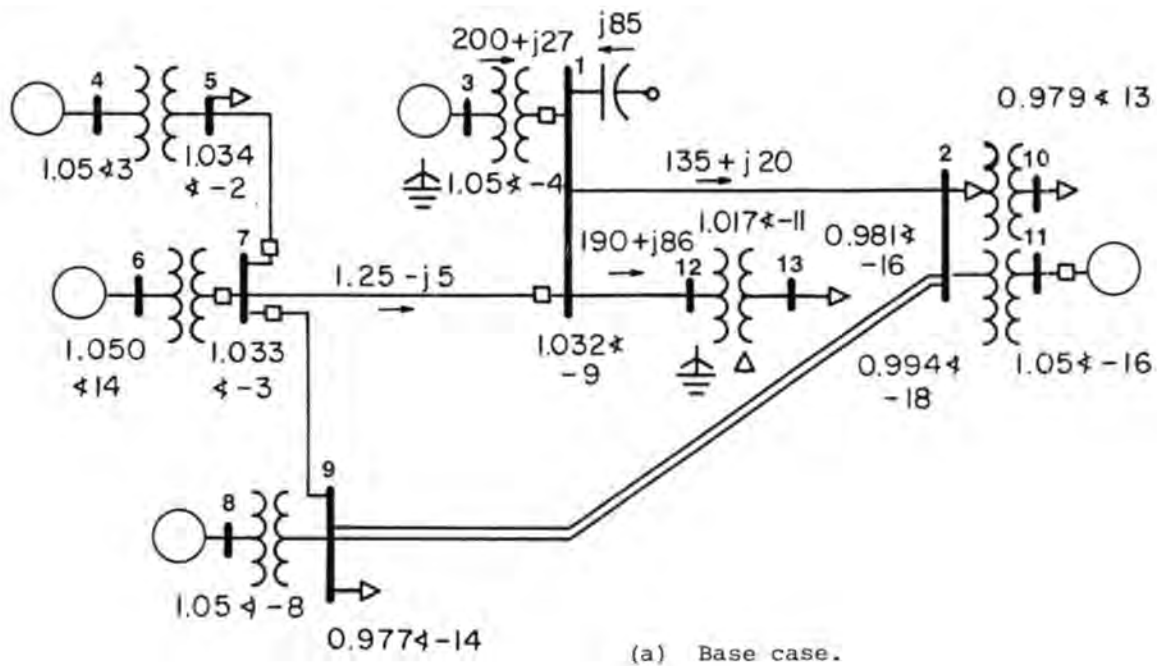

Figure 2.3: Sample load flow results.

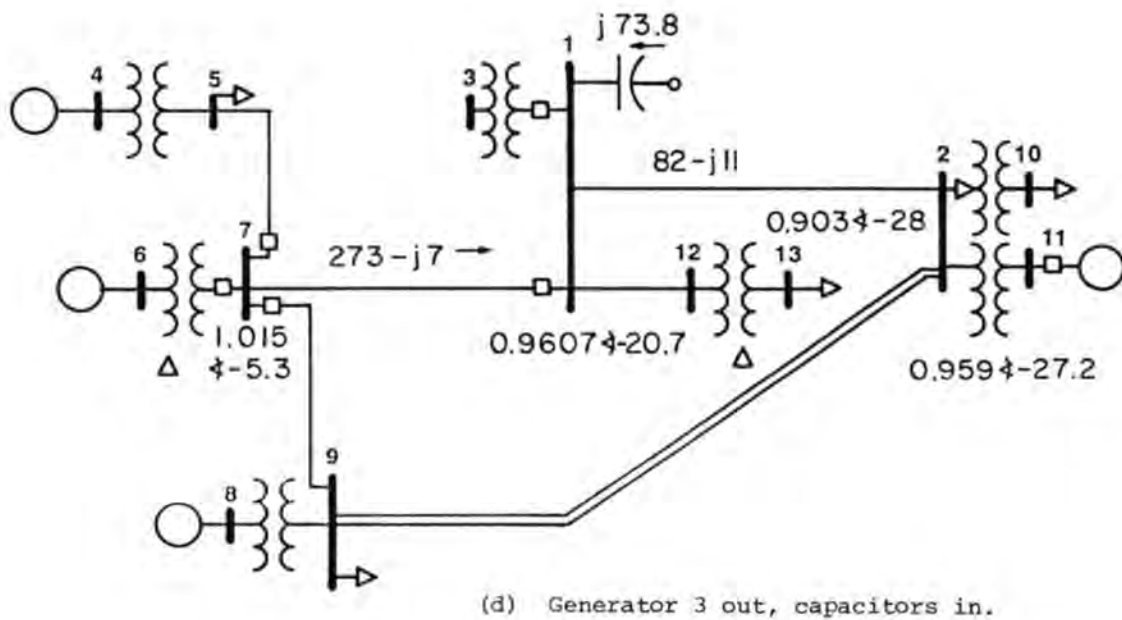
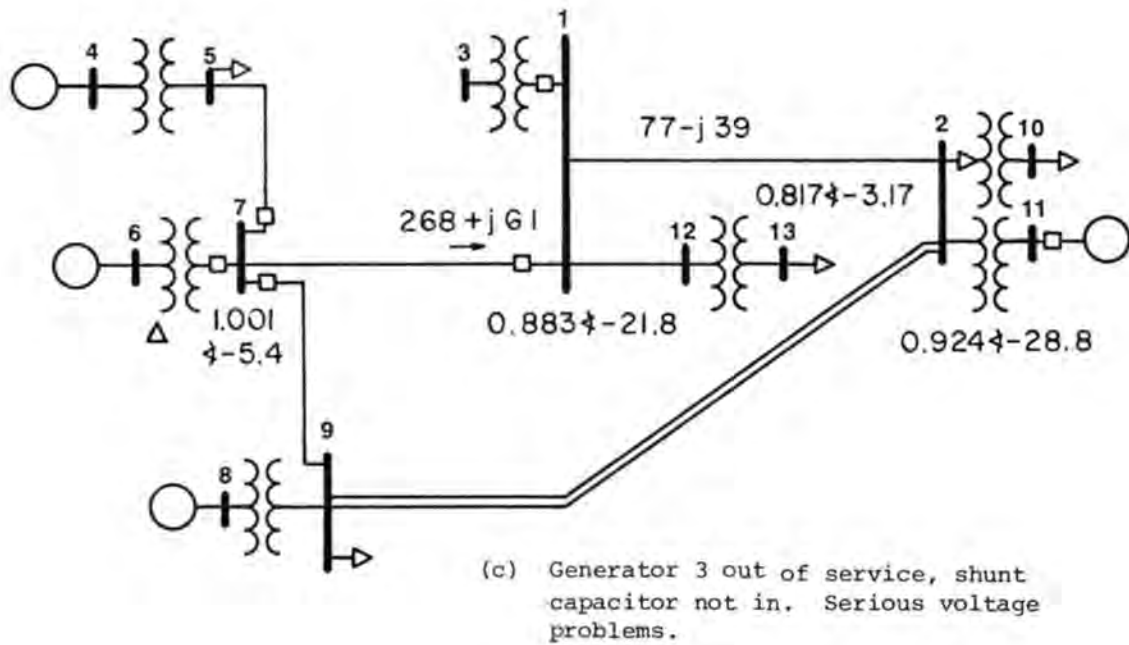

Figure 2.3: (continued).

- A base case with all generators and lines in, capacitors out.
- Generator at bus 3 out of service, capacitors out (for illustration only)
- Generator at bus 3 out of service, capacitors in.
- Line 1-2 out of service.

Table 1-1 illustrates the "common format" data base often available as part of load flow studies. These data are also available in the supplementary diskette.

Short circuit studies on the sample system

The second type of studies often performed on a system are short circuit studies. These studies usually require that simplified positive and zero (and sometimes also negative) sequence diagrams be prepared for the system. The data for these studies is shown in Figure 2.4, the sequence diagrams are illustrated in Figure 2.5 and typical results in Figure 2.6. The data used in these studies is shown in Table 1-2 and in the supplementary diskette. Short circuit studies provide very valuable information for transient studies, as will be seen later in this workbook.

Transient problems to be studied in the sample system

This system will be used to study the following problems:

- Load switching
- Transmission line energization
- Transients due to SLG Faults
- Transient Recovery Voltages (TRV's).
- Reclosing into trapped charges
- Capacitor switching
- Transformer effects
- Lightning and arrestor studies

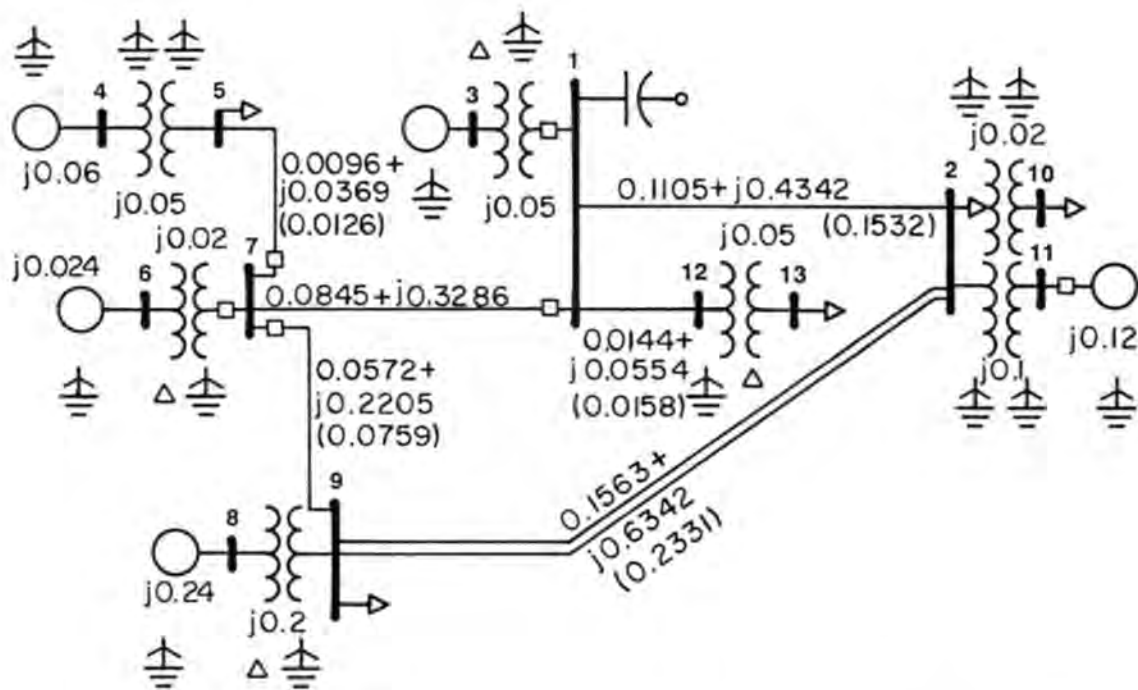

Figure 2.4: Sample system, per-unit zero sequence parameters for short circuit study.

TABLE 2-2

Listing of Data for Short Circuit Studies

BUS DATA in Electrocon Format.

% For each bus:

% Line 1: Number Name Area Zone BaseKV Voltage Angle

% Line 2 (Optional Shunt Data): "S" Code Y0 Y+ Y-

%2345678		112345678		212345678		312345678		412345678		512345678		612345678		71234567890	
	1	BUS1		1	1	230.00	1.00000	0.0							1
	2	BUS2		1	1	230.00	1.00000	0.0							1
	3	GEN3		1	1	13.80	1.00000	0.0							1
S	1	0.0000	-16.667			0.0000	-16.667								
	4	GEN4		1	1	13.80	1.00000	0.0							1
S	1	0.0000	-16.667			0.0000	-16.667								
	5	BUS5		1	1	230.00	1.00000	0.0							1
	6	GEN6		1	1	13.80	1.00000	0.0							1
S	1	0.0000	-41.667			0.0000	-41.667								
	7	BUS7		1	1	230.00	1.00000	0.0							1
	8	GEN8		1	1	13.80	1.00000	0.0							1
S	1	0.0000	-4.1667			0.0000	-4.1667								
	9	BUS9		1	1	230.00	1.00000	0.0							1
	10	BUS10		1	1	230.00	1.00000	0.0							1
	11	GEN11		1	1	13.80	1.00000	0.0							1
S	1	0.0000	-8.3333			0.0000	-8.3333								
	12	BUS12		1	1	230.00	1.00000	0.0							1
	13	BUS13		1	1	69.00	1.00000	0.0							1

TABLE 2-2: (continued).

BRANCH DATA in Electrocon Format.

% For each branch:

% Line 1: From To Circuit Area Zone Number

% Line 2-4: Sequence (P/N/Z), Series Z, Shunt Y (from), Series Z, Shunt Y (to)

%2345678 112345678 212345678 312345678 412345678 512345678 612345678 71234567890

	1	3	1	0	0	1	2						
P	0.000000	0.050000			0.000000	0.000000							
Z	INFINITE				0.000000	-20.0000	INFINITE			0.000000	0.000000		
P	0.001100	0.015800	0.000000	0.030300									
Z	0.014400	0.055400	0.000000	0.018900									
P	0.012700	0.186300	0.000000	0.368200									
Z	0.156300	0.634200	0.000000	0.233100									
P	0.012700	0.186300	0.000000	0.368200									
Z	0.156300	0.634200	0.000000	0.233100									
P	0.000000	0.020000	0.000000	0.000000									
Z	0.000000	0.020000	0.000000	0.000000	0.000000	0.020000	0.000000	0.000000					
P	0.000000	0.100000	0.000000	0.000000									
Z	0.000000	0.100000	0.000000	0.000000									
P	0.000000	0.050000	0.000000	0.000000									
Z	0.000000	0.050000	0.000000	0.000000	0.000000	0.050000	0.000000	0.000000					
P	0.000700	0.010600	0.000000	0.020200									
Z	0.009600	0.036900	0.000000	0.012800									
P	0.000000	0.020000	0.000000	0.000000									
Z	INFINITE				0.000000	0.000000	INFINITE			0.000000	-50.0000		
P	0.004400	0.063400	0.000000	0.121500									
Z	0.057200	0.220500	0.000000	0.075900									
P	0.000000	0.020000	0.000000	0.000000									
Z	INFINITE				0.000000	0.000000	INFINITE			0.000000	-5.00000		
P	0.000000	0.050000	0.000000	0.000000									
Z	0.000000	0.050000	0.000000	0.000000	0.000000	0.050000	0.000000	0.000000					

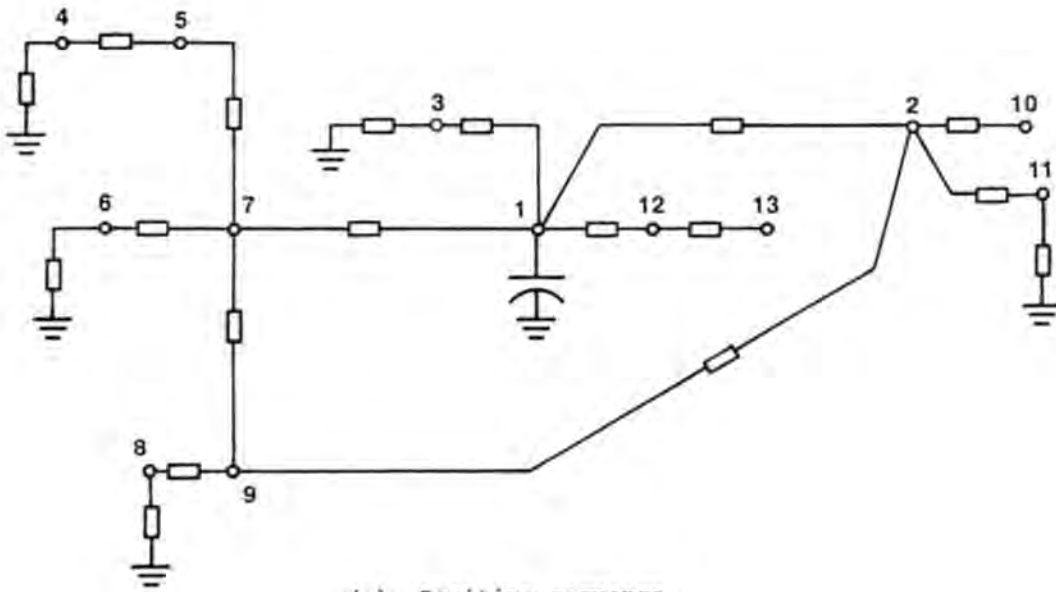

(a) Positive sequence.

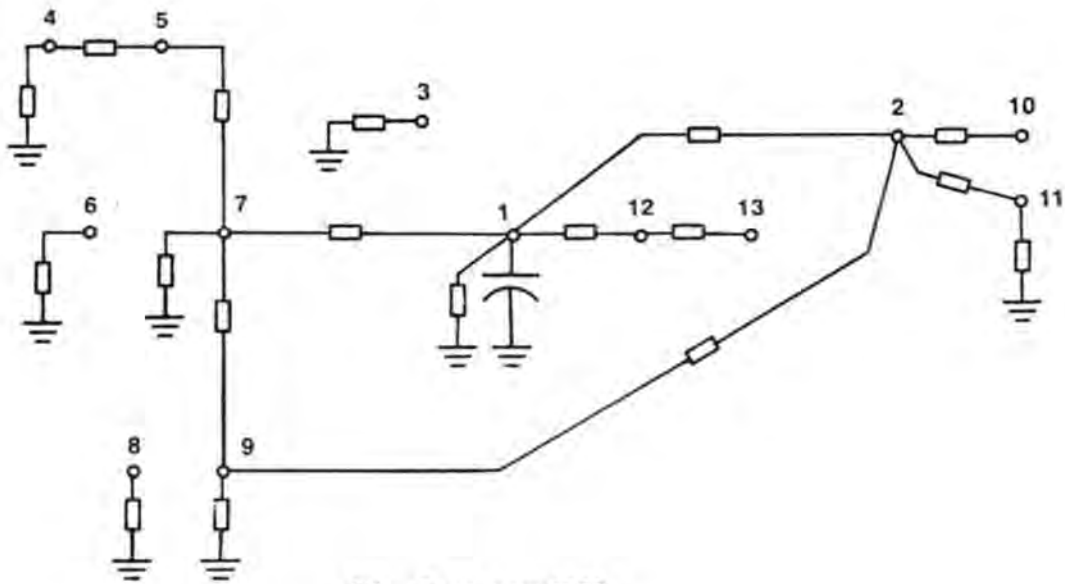

(b) Zero sequence.

Figure 2.5: Obtaining circuit diagrams from one line diagrams.

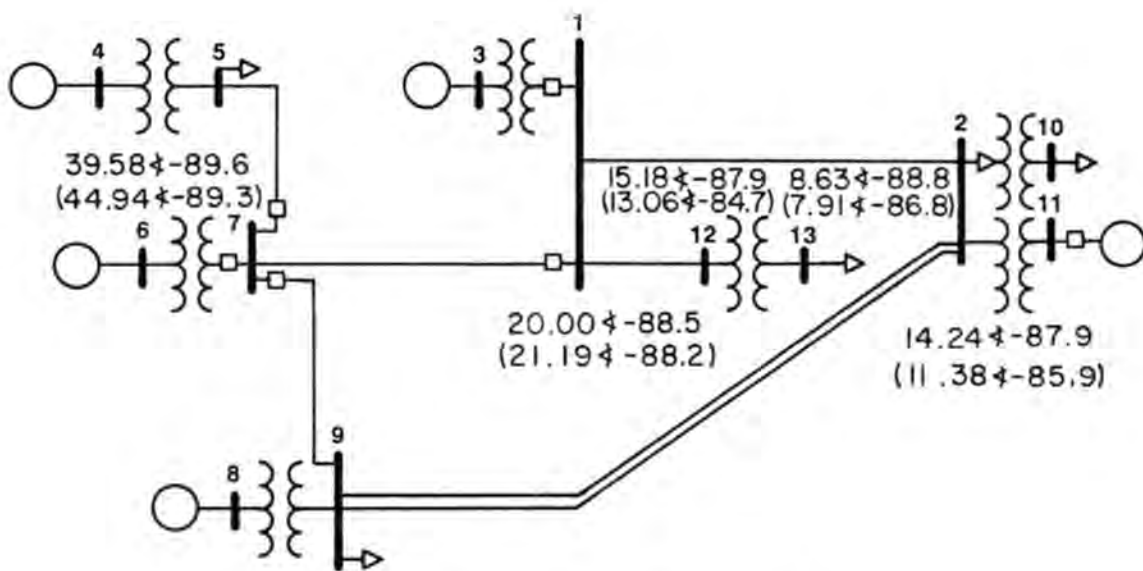

(a) All components in service.

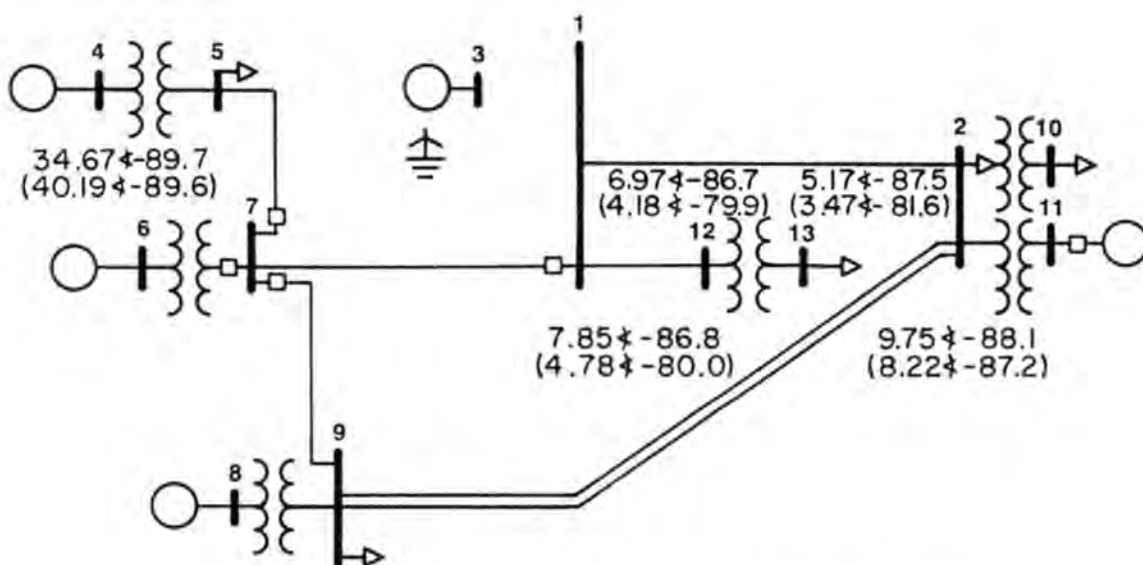

(b) Generator 3 and line 1-2 out of service.

Figure 2.6: Total fault currents for 3 phase (and SLG) faults at designated buses.

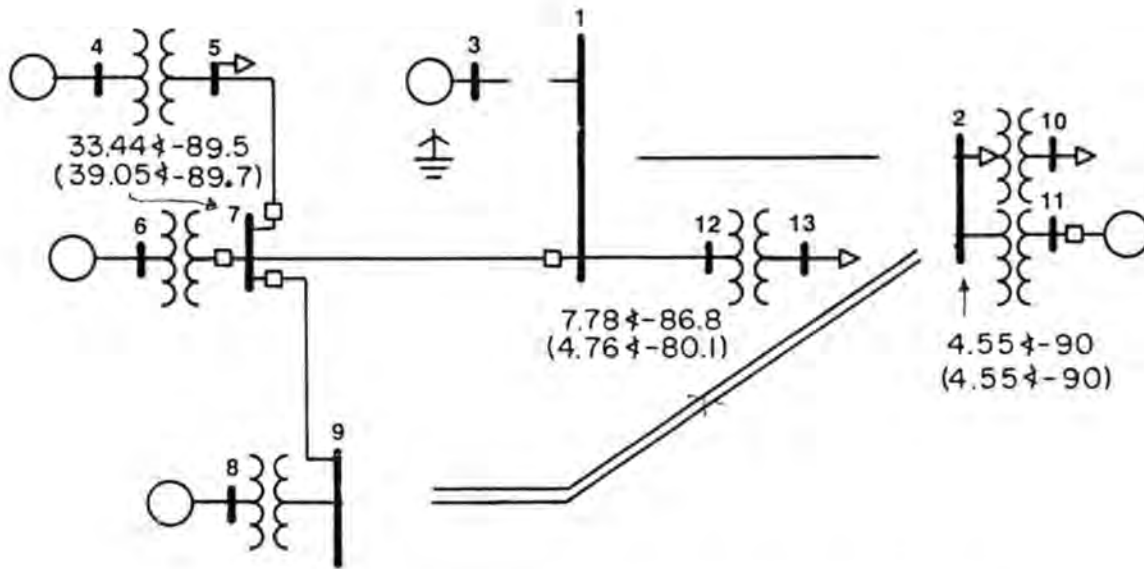

(c) Generator 3, line 1-2 and lines 9-2 out of service.

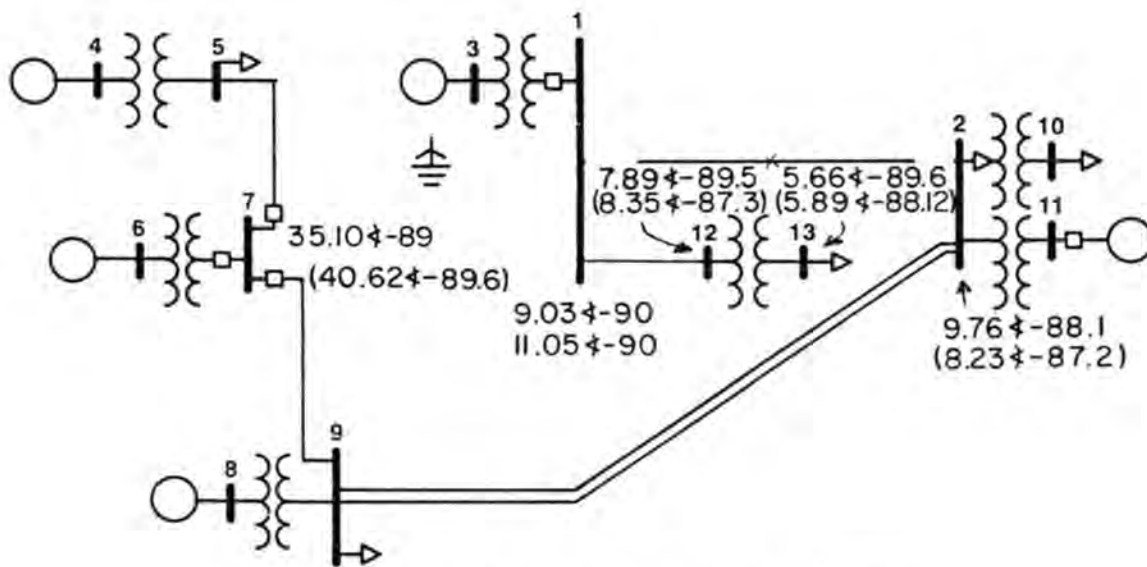

(d) Lines 1-2 and 7-1 out of service.

Figure 2.6: (continued).

Later chapters of this workbook illustrate how to use the data and results from these studies to obtain data for transient studies.

Problem 2.1: From the load flow results illustrated in Figure 2.3(a):

- (a) Verify the flow in line 7-1.
- (b) Determine the P and Q power delivered by the generator at bus 3 under base case conditions.
- (c) Determine the voltage magnitude and phase angle for the voltage behind subtransient reactance for this generator.

Section 3

AN INTRODUCTION TO TRANSIENTS: CLOSING A BREAKER

One of the simplest transient problems is the mere act of closing a breaker connected to a load. This action in itself seldom results in interesting transients worthy of detailed study. However, this simple problem does provide an excellent arena in which to introduce many transients of interest. Consider, for example, the problem of energizing the load at bus 13 by closing the load breaker. Several immediate questions arise:

- How to represent the load.
- How to represent the generators and lines.
- Can "positive sequence only" models be used?
- Can (or should) symmetrical components be used?
- Where to get data for this study.
- How to interpret the results of this study.

Theory of simple switching transients

Consider the circuit in Figure 3.1.

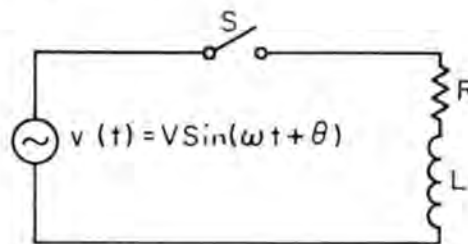

Figure 3.1: An RL circuit with a sine wave source.

The source is assumed to have negligible impedance compared with the load. The source voltage is v , indicating a phasor varying at the supply frequency ω . When the switch S is closed, the equation expressing the current is

$$Ri + L \frac{di}{dt} = s(t) = V_m \sin(\omega t + \theta)$$

The inclusion of the arbitrary phase angle θ permits closing of the switch at any instant in the voltage cycle.

Before attempting to solve this equation consider what is known about the solution. It is clear that in due course the current attains a steady-state value of $|I_{ss}| = \frac{V}{Z}$ where

$$Z = \sqrt{R^2 + \omega^2 L^2}$$

The current is delayed in phase relative to the voltage by an angle ϕ defined as

$$\cos \phi = \frac{R}{Z} = \text{power factor}$$

Except under special circumstances, the current cannot achieve its steady state value instantaneously, because the circuit inductance demands that the current start at zero. There is some transient that leads the current to its steady-state value in a smooth continuous way. Since this is an RL circuit, the exponential $e^{-Rt/L}$ plays an important part in the solution.

The differential equation can be solved using Laplace transforms resulting in a solution

$$i(t) = \frac{V}{Z} \{ \sin(\omega t + \theta - \phi) - \sin(\theta - \phi) e^{-\alpha t} \}$$

where Z and ϕ have been defined and $\alpha = \frac{R}{L}$

This is precisely the form predicted before embarking on the analysis. The first term is the steady-state final value. Its amplitude is V/Z and it indeed has a phase angle $-\phi$ with respect to the voltage. The second term is the transient term. It involves, as expected, an exponential term times a constant. Moreover,

at $t = 0$, it is equal and opposite to the steady-state term, thus assuring that the current starts from zero. Figure 3.2 illustrates this response.

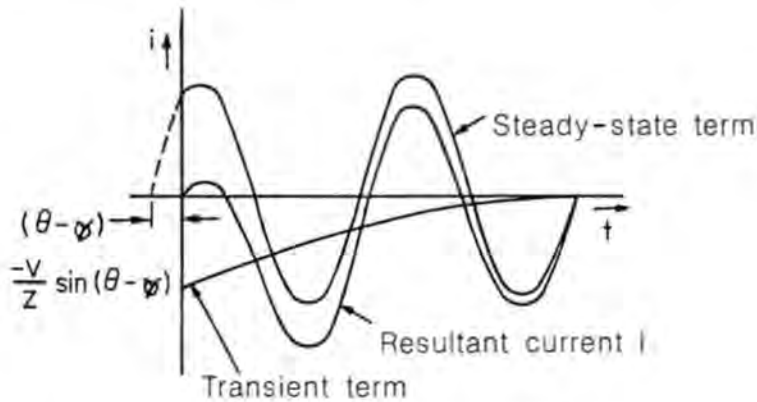

Figure 3.2: Response of RL Circuit

In the very special case where the switch closes at the instant when $\theta = \phi$, the transient term will be zero and the current wave will be symmetrical. On the other hand, if the switch closes when the transient term attains its maximum amplitude and the first peak of the resulting composite current wave will approach twice the peak amplitude of the steady-state sinusoidal component. The peak amplitude is dependent on the switch closing time defined by θ and the power factor through the angle ϕ . This has some significant practical implications for circuit breakers.

For more practical load switching transients we must include capacitors, transformer effects and possible transmission line effect. It becomes clear that the simple case can be of help in understanding the basic behavior but to achieve detailed waveforms a transient analysis program such as the EMTP must be used.

Problem 3.1: For the energization of the RL circuit in Figure 3.1, determine the exact peak current and time at which the peak occurs. Assume energization occurs at $t = 0$, for comparison with later EMTP runs.

To do these calculations, let

$$R = .1 \, \Omega \qquad L = 1 \, \text{mH}$$

$$V = 1 \, \text{pu} \qquad f = 60 \, \text{Hz}$$

θ	I_{peak}	t_{peak}
0°		
45°		
90°		

EMTP simulation of simple switching transients trapezoidal integration

In this section a description of the basic methods used in the EMTP are discussed along with the structure of EMTP input data and the most commonly used input formats. The simple example of energizing an LR load is also presented. The digital computer cannot give a continuous history of transient phenomena but rather a sequence of solutions at discrete intervals Δt . Discretization causes truncation errors which can lead to numerical instability. To avoid numerical instability the EMTP uses the trapezoidal rule for integrating differential equations. This is a simple method which is numerically stable. It does have problems with certain numerical oscillations which are discussed later in this workbook.

The most basic elements are system branches; inductances, capacitances and resistances. The easiest branch is the resistance, for which

$$i_{km}(t) = \frac{1}{R} \{v_k(t) - v_m(t)\}$$

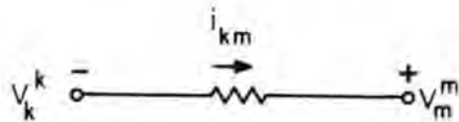

Figure 3.3: EMTP model of a resistor.

The differential equation for the inductance is:

$$v_k - v_m = L \frac{di_{k-m}}{dt}$$

The EMTP replaces this equation with an algebraic equation using the trapezoidal rule of integration:

$$i_{km}(t) = \frac{\Delta t}{2L}(v_k(t)-v_m(t)) + i_{km}(t-\Delta t) + \frac{\Delta t}{2L} [(v_k(t-\Delta t) - v_m(t-\Delta t))]$$

Note that the first term is dependent upon node voltage at time t while the last two terms are dependent on voltage and current one time step Δt before t . These terms would have already been found. This expression can be expressed as a resistance term and a current source calculated one time step back.

$$i_{km}(t) = \frac{\Delta t}{2L} (v_k(t)-v_m(t)) = \frac{1}{R_{eq}} \{v_k(t) - v_m(t)\} + I_{km}(t-\Delta t)$$

where

$$R_{eq} = \frac{2L}{\Delta t}$$

and

$$I_{km}(t-\Delta t) = i_{km}(t-\Delta t) + \frac{1}{R_{eq}} \{v_k(t-\Delta t) - v_m(t-\Delta t)\}$$

The current I_{km} is known from past history. This allows us to replace the inductor with an equivalent resistance and current source :

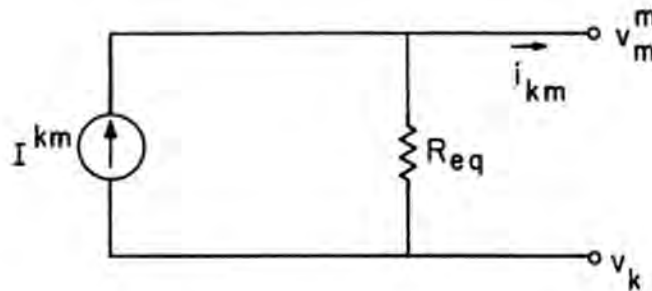

Figure 3.4: EMTP model of inductor and capacitor.

The branch equation for the capacitance is derived analogously. It becomes

$$i_{km}(t) = \frac{1}{R} \{v_k(t)-v_m(t)\} + i_{km}(t-\Delta t)$$

where

$$R_{eq} = \frac{\Delta t}{2C}$$

and

$$I_{km}(t-\Delta t) = -\frac{1}{R} \{V_k(t-\Delta t) - v_m(t-\Delta t)\} - i_{km}(t-\Delta t)$$

This results in the same form for the equivalent network. Thus, all branch components have a simple "Norton equivalent" circuit. Consider again the simple RL network in Figure 3.4. We could replace the L & R with their Norton equivalent networks. The result would be the network illustrated in Figure 3.5

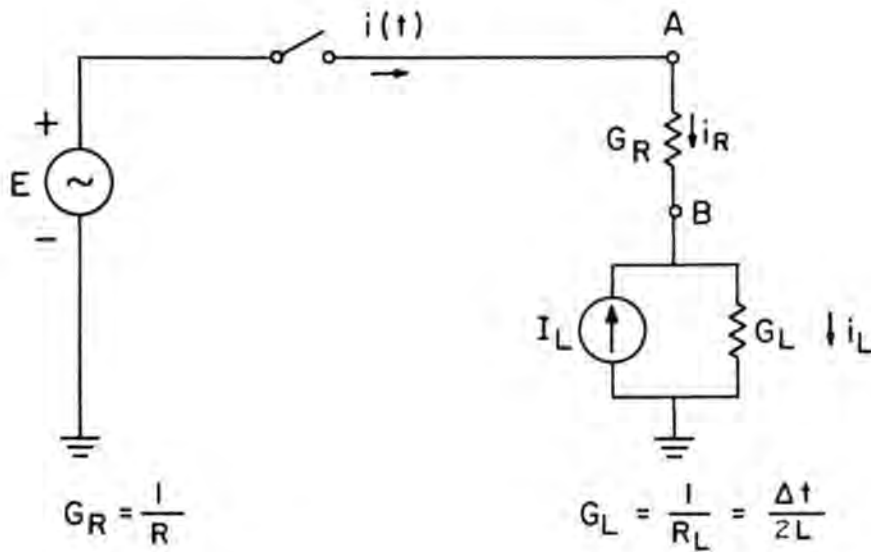

Figure 3.5: The equivalent conductance network used by the EMTP for an RL circuit.

The EMTP then solves this problem by construction a set nodal simultaneous equations:

$$\bar{I}(t) = [G] \bar{v}(t) + \bar{I}(t-\Delta t)$$

[G] is the nodal admittance matrix. Solving these equation yields $\bar{v}(t)$.

Problem 3.2: You have specified a solution time step $\Delta t = 1$ ms, and a 1 mH inductor. What is the conductance in mhos that the EMTP will use internally to represent this inductor?

G = _____ mhos

Preparing a Basic EMTP Input Data Case

This section describes the basic structure of an EMTP input data with the needed formats to model R, L, and C components and to study switching transients. The structure of the EMTP input data is shown in Table 3-1. Most data sections are separated by a blank card. For convenience, the user can enter a blank line as "BLANK" line starting in column 1. This will be interpreted by the EMTP as a blank line. Comment lines can also be added to the input data by entering a "C-blank" in Columns 1 and 2. Additional comment text can also be added after a "BLANK" line. Comment lines are used extensively in the sample cases in this workbook. The EMTP prints these lines in the record of input data, but otherwise ignores them.

TABLE 3-1
EMTP Input Data Structure

BEGIN NEW DATA CASE (one line)
 Fixed-point Miscellaneous Data Line
 Integer Miscellaneous Data Line
 Branch, Transformer and Transmission Line Data
 BLANK
 Switch Data
 BLANK
 Source Data
 BLANK
 Node Voltage Output Request Data
 BLANK
 PLOT Request Data
 BLANK
 BLANK (Ends the case)

BEGIN NEW DATA CASE: This line always precedes all input data cases.

Fixed-Point Miscellaneous Data Line: This data line contains seven real number parameters to be entered in fields eight columns wide. Only the four parameters shown below are used in this workbook.

<u>DELTAT</u>	<u>TMAX</u>	<u>XOPT</u>	<u>COPT</u>
E8.0	E8.0	E8.0	E8.0

DELTAT is the time step used in the simulation. It must always be greater than zero. This time step should not be too large. In general, Δt should result in ten sample points in the highest frequency of interest.

TMAX is the length of time to be simulated. It can be equal to or less than zero, in which case the EMTP performs a steady-state solution of the initial conditions only, and does not perform a transient simulation.

XOPT is the power frequency for purposes of inductance specification. If it is zero or blank, all inductances are entered in millihenries. If it is 60.0, for example, all inductances are entered as reactive ohms at 60 Hertz.

COPT is the power frequency for purposes of capacitance specification. If it is zero or blank, all capacitances are entered in microfarads. If it is 60.0, for example, all capacitances are entered as micro-ohms at 60 Hertz.

Integer Miscellaneous Data Line: This data line contains up to ten integer parameters, which are entered right-justified in fields eight columns wide. Only the seven parameters shown below are used in this workbook.

<u>IPRNT</u>	<u>IPLOT</u>	<u>IDOUBL</u>	<u>KSSOUT</u>	<u>MAXOUT</u>		<u>ICAT</u>	<u>NENERG</u>
I8	I8	I8	I8	I8	16X	I8	I8

IPRNT - This parameter specifies the rate at which output variables are printed during the simulation. If IPRNT is zero or one, each time step is printed. If IPRNT = k, then every kth time step is printed. IPRNT should always be either blank or equal to an odd number. Even numbers will permit numerical oscillations to exist which the user cannot detect in the output.

I PLOT - This parameter specifies the rate at which output variables are plotted during the simulation in exactly the same way that IOUT controls printed output. I PLOT should also be either blank or equal to an odd number.

I DOUBL - Setting I DOUBL equal to one will cause a network topology listing to be printed out. It is useful in checking branch and switch connections when setting up a case.

KSSOUT - Setting KSSOUT equal to one will cause a complete steady-state voltage and current solution to be printed for each branch in the network. KSSOUT equal to two causes only switch and source steady-state solutions to be printed. KSSOUT equal to three causes switch, source, and requested output variable steady-state solutions to be printed.

MAXOUT - Setting MAXOUT equal to one will cause the EMTP to print the maximum values attained by each output variable during the transient simulation.

I CAT - Setting I CAT equal to one causes all plot data generated by the EMTP to be saved on disk for future plotting by a separate program.

NENERG - Setting NENERG greater than zero causes a probabilistic switching simulation to be performed.

Branch Data: Only the single-phase, lumped-parameter branches shown in Figure 3.6 are used in the RLC circuit examples.

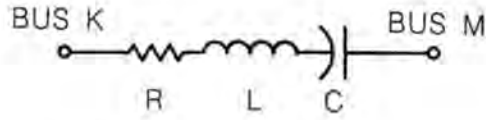

Figure 3.6: Series RLC Branch

The parameters are entered in fields six columns wide. Resistances are input in ohms. Inductances are specified in ohms or milihenries and capacitances are specified in micro-ohms or microfarads. A request to output branch current and branch voltage variables is specified on data lines by a nonzero entry in column 80. Node voltage outputs are specified in a separate data group. The branch data input format is shown below:

	<u>BUS K</u>	<u>BUS M</u>		<u>R</u>	<u>L</u>	<u>C</u>		<u>BRANCH OUTPUT</u>
2X	A6	A6	12X	E6.0	E6.0	E6.0	35X	I1

BUS K and BUS M are the six-character node names on the user's schematic diagram of the system. Care should be taken to assign unique names to all nodes. The parameters R, L and C are the resistance, inductance, and capacitance (in series) of the branch. One of these parameters must be non-zero. If either BUS K or BUS M is left blank, the branch is assumed to be connected from a node to ground.

BRANCH OUTPUT is a single integer which requests branch variable output. Use a 1 to request branch current outputs, Other options include a 2 to have the branch differential voltage output, a 3 to have both branch current and voltage output. and a 4 to have branch power and energy output.

If columns 15 to 26 contain the bus names of a previously entered branch, the EMTP uses the parameters of this branch instead.

Switch Data: The format of these data lines is similar to the branch data, except that switch closing and opening times are specified rather than R, L, and C. Ordinary EMTP switch models perform one close-open operation during the simulation. A diagram for the switch depicted in Figure 3.7. The format is listed below.

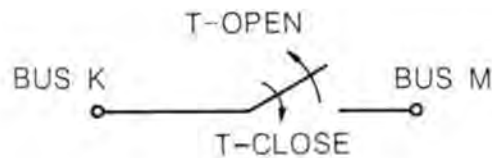

NOTE: T-OPEN > T-CLOSE

Figure 3.7: A Simple Switch

	<u>BUS K</u>	<u>BUS M</u>	<u>T-CLOSE</u>	<u>T-OPEN</u>		<u>BRANCH OUTPUT</u>
2X	A6	A6	E10.0	E10.0	45X	11

The switch is connected between nodes BUS K and BUS M, one of which may be left blank to indicate a switch to ground. T-CLOSE and T-OPEN are specified in seconds. A negative T-CLOSE may be used to indicate a switch which is already closed in the steady state. If T-OPEN is left blank or is assigned a value greater than TMAX, the switch will never open during the simulation. Branch current and voltage outputs may also be requested for switches in the same way as for branches.

Source Data: A variety of source types are available in the EMTP. Step functions and cosine functions shown in Figure 3.8 are often used. The sources can be either node voltages to ground or currents injected at the node. Input formats are shown below.

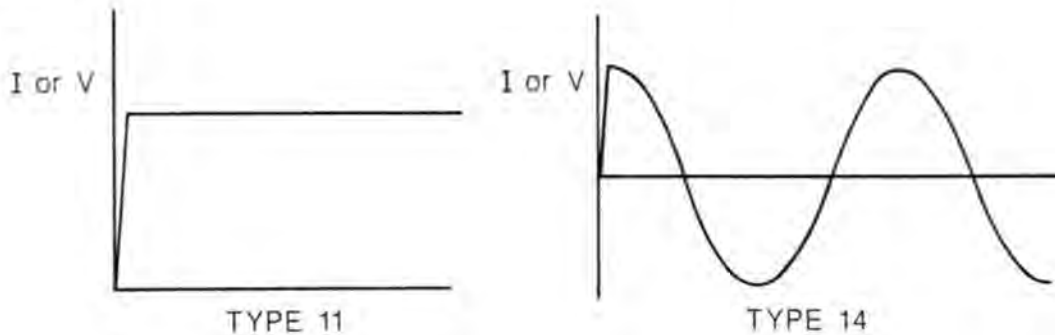

Figure 3.8: Basic Source Types

<u>TYPE</u>	<u>BUS</u>	<u>V OR I</u>	<u>AMPLITUDE</u>	<u>FREQUENCY</u>	<u>TO/PHIO</u>	<u>A1</u>	<u>TSTART</u>	<u>TSTOP</u>
I2	A6	I2	E10.6	E10.6	E10.6	E10.6	E10.6	E10.6

TYPE is a two-digit integer: 11=step function
14=cosine function.

BUS is the node name where the source is connected (sources are always from ground)

V OR I is a two-digit integer: blank=voltage source
-1=current source.

AMPLITUDE is the current or voltage level of the step, or the amplitude in peak units line-to-ground of the cosine wave.

FREQUENCY is the frequency in Hertz of a cosine function (blank for step function).

TO/PHIO is the phase angle in degrees (or time offset in seconds) of the cosine function (blank for step function).

EMTP sources become active in the first time step of the transient simulation. However, sinusoidal (type 14) sources of fundamental frequency with negative "TSTART" are active in the pre-transient steady state. Sources become inactive when $t < TSTART$ or when $t > TSTOP$. An inactive voltage source is a short circuit. If more than one input voltage source is connected to a node, the sources are combined in series.

Node Voltage Output Request Data: These data lines immediately follow the initial condition data (if any). Node voltage output request data lines specify the names of nodes where the voltage to ground is desired. Initial condition data lines are not described in this workbook and are seldom needed.

A single data line can be used with a "1" in Column 2 to request all node voltages to be output. In this case, DO NOT use the BLANK data line which normally terminates the node voltage output request data.

To select individual node voltages to be output, use the format below.

	<u>BUS 1</u>	<u>BUS 2</u> <u>BUS 13</u>	
2X	A6	A6	A6

Each line contains node names of the output voltages. More than one node voltage output line may be used if there are more than 13 voltages to be output. However, there is an upper limit on the number of output variables which varies from installation to installation.

On each data line, BUS 1 must be non-blank.

Plot Request Data: The lines for batch-mode plots fall in two general types. The first (optional) type specifies line printer or Calcomp plots, the plot title and a few other features. The organization of these lines is shown below.

<u>Col. 1-2</u>	<u>Col. 3-80</u>
"bb"	"CALCOMP PLOT" or "PRINTER PLOT"
"bb"	CASE TITLE
"02"	CASE SUBTITLE
"01"	PLOT REQUEST

ALCOMP PLOT may not be operational at each installation, but PRINTER PLOT will always produce plots in the EMTP printout using alphanumeric characters. For that reason, these plots are harder to use than CALCOMP PLOTS. Whichever type is used, the specification of each individual plot is made using the format shown below.

<u>FLAG</u>	<u>TYPE</u>	<u>UNITS</u>	<u>UPI</u>	<u>ORIG</u>	<u>END</u>	<u>BUS 1</u>	<u>BUS 2</u>	<u>BUS 3</u>	<u>BUS 4</u>
I2	I1	I1	E3.0	E4.0	E4.0	9X	A6	A6	A6

FLAG is always equal to 1 in Column 2.

TYPE=4 for a node voltage plot.

=8 for a branch voltage plot.

=9 for a branch current plot.

UNITS=3 for a time scale in seconds.

=4 for a time scale in milliseconds.

=5 for a time scale in microseconds.

UPI is the number of UNITS per inch.

ORIG is the beginning time (in "UNITS") of the plot.

END is the ending time (in "UNITS") of the plot.

In most cases, UPI, ORIG, and END should be chosen to get a total time-scale length of 10 to 12 inches. That is, let $(END-ORIG)/UPI = 10$ or 12 . UPI should be a convenient scaling division, since the grid lines are drawn one per inch.

If a node voltage plot is being made, up to four different node voltages may be plotted on the same graph. If a branch voltage or current plot is being made, BUS 1 and BUS 2 are the branch node names as specified in the EMTP simulation. BUS 3

and BUS 4 may contain node names for a second branch variable to be plotted on the same graph.

Basic data for the LR load switching transient example in Figure 3.1 is shown in Figure 3.9(a). The EMTP simulation output is given in Figure 3.9(b) and plots of the energization current given in Figure 3.9(c)

Problem 3.3: Compare the results of Figure 3.9 with analytically calculated values for several values of time.

ELECTROMAGNETIC TRANSIENTS PROGRAM (EMTP), APOLLO TRANSLATION, AS USED BY BONNVILLE POWER ADMINISTRATION, PORTLAND, OREGON (USA).
 DATE (MM/DD/YY) AND TIME OF DAY (HH.MM.SS) = 03/07/86 16.10.40 NAME OF PLOT FILE (IF ANY) = PLOT030786161040.PL4
 FOR INFORMATION, CONSULT THE 840-PAGE EMTP RULE BOOK DATED MARCH, 1983. PROGRAM VERSION = "M39." OR JUST BEFORE.
 INDEPENDENT LIST LIMITS FOLLOW. TOTAL LENGTH OF /LABEL/ EQUALS 191816 INTEGER WORDS. 752 900 1500 300 7500
 120 1650 5250 225 480 150 150 15 1380 150 120 12 15 4800 1950 300 450 12000 9 1200 150 150

DESCRIPTIVE INTERPRETATION OF NEW-CASE INPUT DATA INPUT DATA CARD IMAGES PRINTED BELOW, ALL 80 COLUMNS, CHARACTER BY CHARACTER.
 0 1 2 3 4 5 6 7 8
 0 0 0 0 0 0 0 0 0

```

COMMENT CARD. IC #ATTACH,r1,example.
MARKER CARD PRECEDING NEW DATA CASE. IBEGIN NEW DATA CASE
COMMENT CARD. IC RL.....
COMMENT CARD. IC Energization of a trivial RL circuit. Figure 3.9(b).
COMMENT CARD. IC ----dt---tmax 1 200.E-6 50.E-3
MISC. DATA. 0.200E-03 0.500E-01 0.000E+00 1 200.E-6 50.E-3
COMMENT CARD. IC -Iprnt<--Iplot<-Idoubt<-KssOut<-MaxOut <---Icat
MISC. DATA. 25 1 1 0 0 0 0 0 0 0 1 25 1 1 0 0 0
COMMENT CARD. IC
COMMENT CARD. IC Circuit data.....
COMMENT CARD. IC Bus-->Bus-->Bus-->Bus--><---R<---L<---C 0
SERIES R-L-C. 0.100E+00 0.100E+01 0.000E+00 1 LOAD .1 1. 0
BLANK CARD TERMINATING BRANCH CARDS. IBLANK End of circuit data.....
COMMENT CARD. IC
COMMENT CARD. IC Switch data.....
COMMENT CARD. IC Bus-->Bus--><---fclose<---fopen<---Ie 0
SWITCH. 0.10E-02 0.10E+05 0.00E+00 0.00E+00 1 SRC LOAD 1.E-3 9999. 0 1
BLANK CARD TERMINATING SWITCH CARDS. IBLANK End of switch data.....
COMMENT CARD. IC
COMMENT CARD. IC Source data.....
COMMENT CARD. IC Bus--><I<Amplitude<Frequency<---T0IPhi0<---0<Phi0<-Ignore-><---Istart<---Istop
SOURCE. 0.10E+01 0.60E+02 0.00E+00 -0.10E+01 114SRC 1. 60. 0 0. -1. 9999.
BLANK CARD TERMINATING SOURCE CARDS. IBLANK End of source data.....
  
```

LIST OF INPUT ELEMENTS CONNECTED TO EACH BUS.
 1) ONLY THE PHYSICAL CONNECTIONS OF MULTIPHASE LINES ARE SHOWN (CAPACITIVE AND INDUCTIVE COUPLING IGNORED)
 2) REPEATED ENTRIES IMPLY PARALLEL CONNECTIONS
 3) SOURCES ARE OMITTED, ALTHOUGH SWITCHES ARE INCLUDED;
 4) U.M. USAGE PRODUCES EXTRA, INTERNALLY-DEFINED NODES "UM????" (1ST 2 LETTERS "UM").

FROM BUS NAME: 1 NAMES OF ALL ADJACENT BUSES

```

LOAD ITERRA *SRC *
SRC ILOAD *
TERRA ILOAD *
  
```

```

PI-EQUIV BRANCHES OF DISTRIB LINES IN TR, TX, ETC. BETWEEN LIMITS 2 1
COMMENT CARD. IC
COMMENT CARD. IC Nodal Output Request Data.....
COMMENT CARD. IC Bus-->Bus-->Bus-->Bus-->Bus-->Bus-->Bus-->Bus-->Bus-->Bus-->Bus-->Bus-->Bus-->
CARD OF BUS NAMES FOR NODE-VOLTAGE OUTPUT. 1 SRC LOAD
BLANK CARD ENDING NODE NAMES FOR VOLTAGE OUTPUT. IBLANK End of output requests.....
  
```

COLUMN HEADINGS FOR THE 3 EMTP OUTPUT VARIABLES FOLLOW. THESE ARE ORDERED ACCORDING TO THE FIVE POSSIBLE EMTP OUTPUT-VARIABLE CLASSES, AS FOLLOWS
 FIRST 2 OUTPUT VARIABLES ARE ELECTRIC-NETWORK NODE VOLTAGES (WITH RESPECT TO LOCAL GROUND);
 NEXT 0 OUTPUT VARIABLES ARE BRANCH VOLTAGES (VOLTAGE OF UPPER NODE MINUS VOLTAGE OF LOWER NODE);
 NEXT 1 OUTPUT VARIABLES ARE BRANCH CURRENTS (FLOWING FROM THE UPPER EMTP NODE TO THE LOWER);

(b) Sample output.

Figure 3.9: (continued).

NEXT 0 OUTPUT VARIABLES PERTAIN TO DYNAMIC SYNCHRONOUS MACHINES, WITH NAMES GENERATED INTERNALLY!
 FINAL 0 OUTPUT VARIABLES BELONG TO 'TACS' (NOTE INTERNALLY-ADDED UPPER NAME OF PAIR).
 BRANCH POWER CONSUMPTION (POWER FLOW, IF A SWITCH) IS TREATED LIKE A BRANCH VOLTAGE FOR THIS GROUPING!
 BRANCH ENERGY CONSUMPTION (ENERGY FLOW, IF A SWITCH) IS TREATED LIKE A BRANCH CURRENT FOR THIS GROUPING.

```
STEP  TIME      SRC      LOAD      SRC
      LOAD
0 0.100000 0.100000E+01 0.000000E+00 0.000000E+00
***
25 0.025000-0.309017E+00-0.309017E+00 0.10e+44E+01
50 0.010000-0.309017E+00-0.309017E+00-0.2e44E+01
75 0.015000 0.309017E+00 0.309017E+00-0.132331E+01
100 0.020000 0.309017E+00 0.309017E+00 0.231714E+01
125 0.025000-0.100000E+01-0.100000E+01-0.802417E+00
150 0.030000 0.309017E+00 0.309017E+00-0.224193E+01
175 0.035000 0.309017E+00 0.309017E+00 0.173346E+01
200 0.040000-0.309017E+00-0.309017E+00 0.391990E+00
225 0.045000-0.309017E+00-0.309017E+00-0.257875E+01
250 0.050000 0.100000E+01 0.100000E+01 0.644749E+00
```

SWITCH "SRC" TO "LOAD" CLOSED AFTER 0.100000E+02 SEC.

```
COMMENT CARD. IC
COMMENT CARD. IC Plot request Data.....
PLOT SUBTITLE CARD. I Figure 3.9(c): Output Plot for Switch Current
COMMENT CARD. IC Graph type: 4(volts) 8(branch volts) 9(currents)
COMMENT CARD. IC Units: 1(deg) 2(cyc) 3(sec) 4(msec) 5(microsec)
COMMENT CARD. IC Units per inch
COMMENT CARD. IC Plot starting time
COMMENT CARD. IC Plot stopping time
COMMENT CARD. IC Value at bottom of vertical axis (optional)
COMMENT CARD. IC Value at top of vertical axis (optional)
COMMENT CARD. IC VV(---|---|---|---|---|Bus--|Bus--|Bus--|Bus--|Heading--|Vert axis--|)
** PLOT CARD. 0.500E+01 0.000E+00 0.500E+02 1 194 5, 0.0 50, +4, 4.SRC LOAD RL Energization Amps
BLANK CARD TERMINATING PLOT SPEC. CARDS. IBLANK End of Plot Request Data.....
```

CORE STORAGE FIGURES FOR PRECEDING DATA CASE NOW COMPLETED.

SIZE LIST	DESCRIPTION	PRESENT FIGURE	PROGRAM LIMIT (NAME)
SIZE LIST 1.	NUMBER OF NETWORK NODES.	3	752 (LBUS)
SIZE LIST 2.	NUMBER OF NETWORK BRANCHES.	1	900 (LBRNCH)
SIZE LIST 3.	NUMBER OF DATA VALUES IN R, L, C TABLES.	1	1500 (LDATA)
SIZE LIST 4.	NUMBER OF ENTRIES IN SOURCE TABLE.	1	300 (LEXCT)
SIZE LIST 5.	STORAGE FOR (Y) AND TRIANGULARIZED (Y). NO. TIMES = 2 FACTORS = 0	2	7500 (LYMAT)
SIZE LIST 6.	NUMBER OF ENTRIES IN SWITCH TABLE. NO. FLGPs = 1	1	120 (LSWICH)
SIZE LIST 7.	NUMBER OF TOTAL DISTINCT ALPHANUMERIC (As) PROGRAM NAMES	2	1650 (LSIZE7)
SIZE LIST 8.	NUMBER OF PAST HISTORY POINTS FOR DISTRIBUTED LINES.	0	5250 (LPAST)
SIZE LIST 9.	NUMBER OF NON-LINEAR ELEMENTS.	0	225 (LNONL)
SIZE LIST 10.	NUMBER OF POINTS DEFINING NON-LINEAR CHARACTERISTICS.	0	490 (LCHAR)
SIZE LIST 11.	NUMBER OF BRANCH OR SELECTIVE-NODE-VOLTAGE OUTPUTS.	2	150 (LSMOUT)
SIZE LIST 12.	NUMBER OF OUTPUT QUANTITIES (LIMITED ONLY WHEN PRINTING MAX ABSOLUTE VALUES).	3	150 (LSIZ12)
SIZE LIST 13.	NUMBER OF 'WEIGHTING' FREQUENCY-DEPENDENT LINE MODES.	0	15 (LFDEP)
SIZE LIST 14.	NUMBER OF CELLS USED TO STORE FREQ.-DEPENDENCE WEIGHTING FUNCTIONS.	0	1380 (LWT)
SIZE LIST 15.	NUMBER OF CELLS USED FOR EXPONENTIAL-TAIL LINE-HISTORY STORAGE.	0	150 (LTAILS)
SIZE LIST 16.	TOTAL NUMBER OF TYPE-59 S.M. MASSES.	0	120 (LMASS)
SIZE LIST 17.	NUMBER OF DYNAMIC SYNCHRONOUS MACHINES.	0	12 (LSYN)
SIZE LIST 18.	NUMBER OF BRANCH POWER-AND-ENERGY OUTPUTS.	0	15 (MAXPE)
SIZE LIST 19.	FLOATING-POINT WORKING SPACE FOR ALL TACS ARRAYS.	137	4800 (LTACST)
SIZE LIST 20.	RECURSIVE CONVOLUTION PARAMETER STORAGE FOR NON-COPIED BRANCH COMPONENTS.	0	1950 (LFSEM)
SIZE LIST 21.	TOTAL STORAGE CELLS FOR MODAL-PHASE TRANSFORMATION MATRICES.	0	300 (LFD)
SIZE LIST 22.	NUMBER OF CELLS FOR CONVOLUTION HISTORY.	0	450 (LHIST)
SIZE LIST 23.	GIANT ARRAYS FOR RENUMBERING AND STEADY-STATE SOLUTION CALCULATIONS.	1	12000 (LSIZ23)

(b) Sample output.

Figure 3.9: (continued).

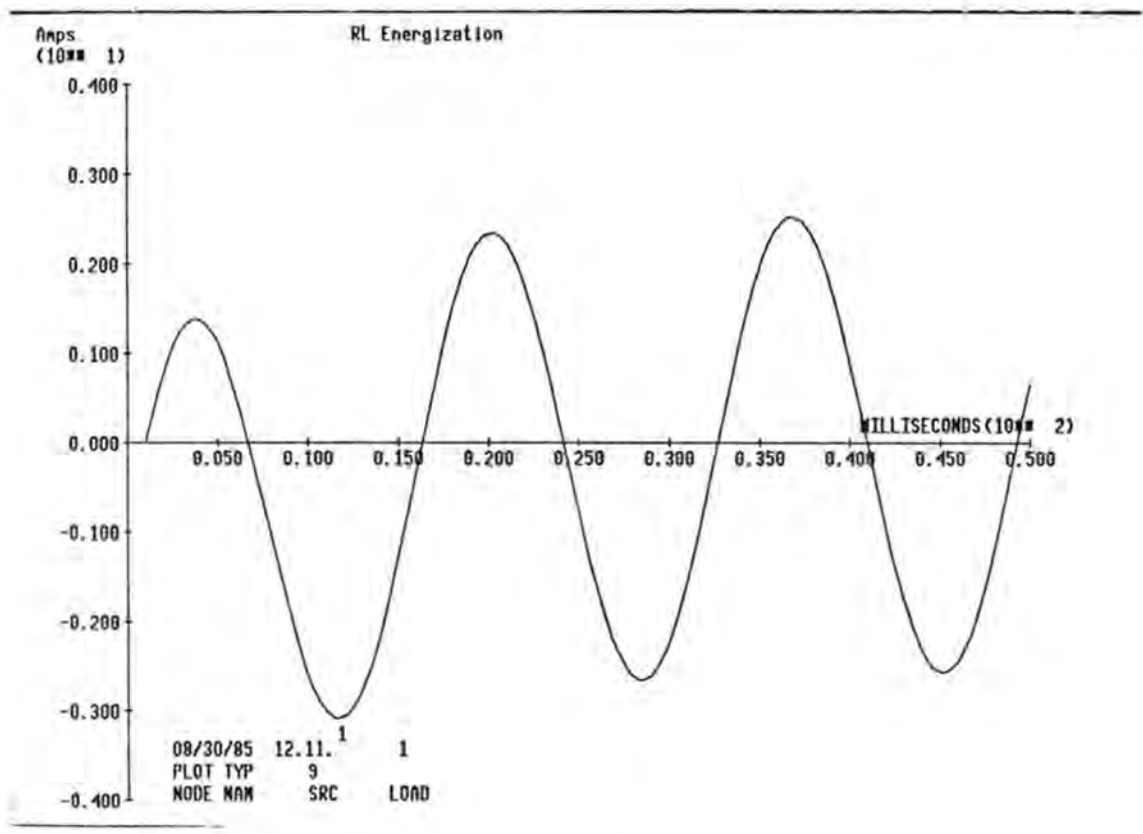

(c) Output plot for current.

Figure 3.9: (continued).

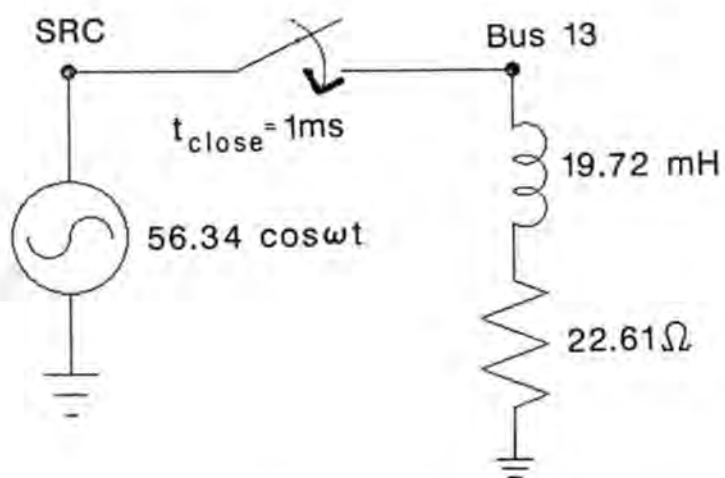

(a) Circuit diagram.

Figure 3.10: Energization of single phase .95 pf RL load from ideal source.

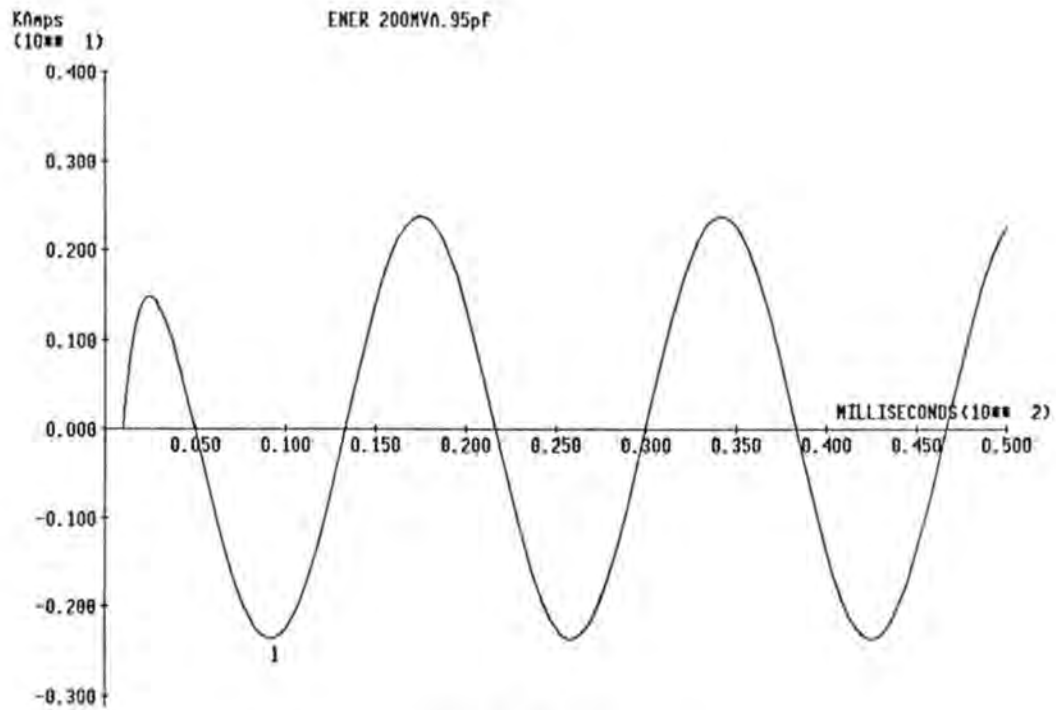

(c) Load current.

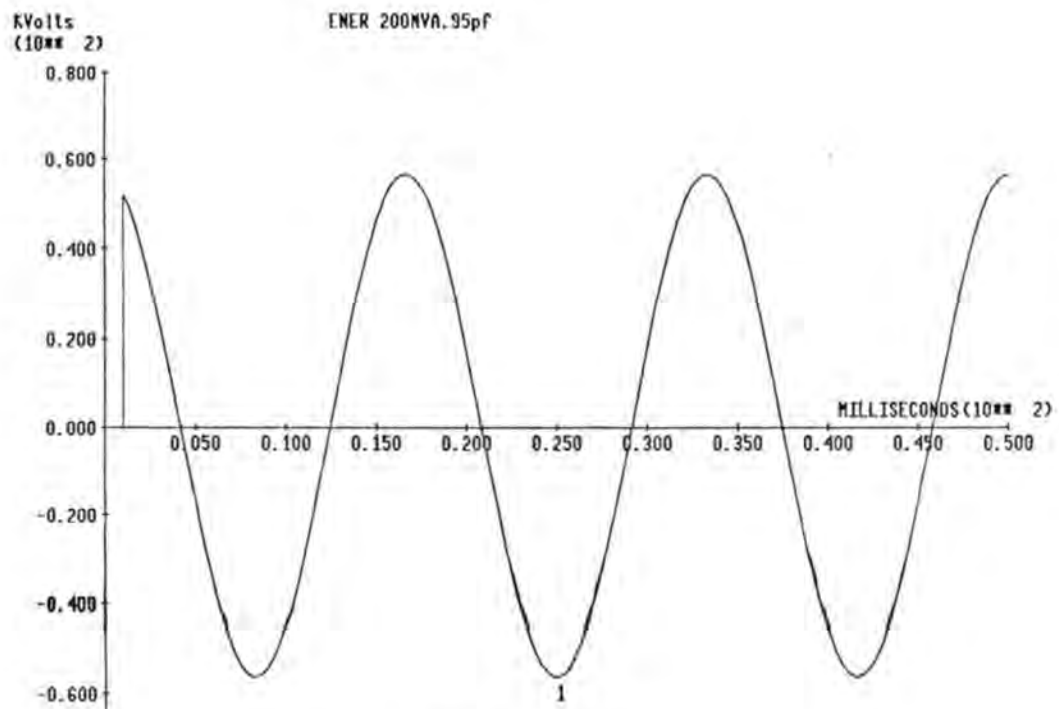

(d) Load voltage.

Figure 3.10: (continued).

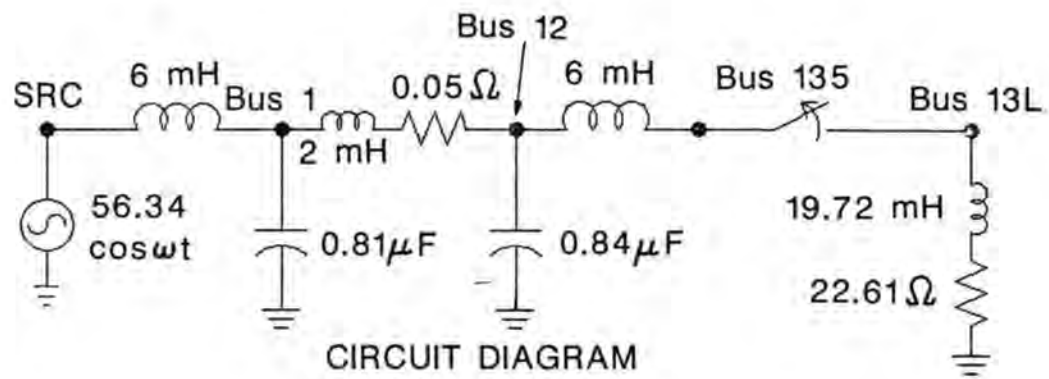

(a) Circuit diagram.

Figure 3.11: Energization of .95 pf load.

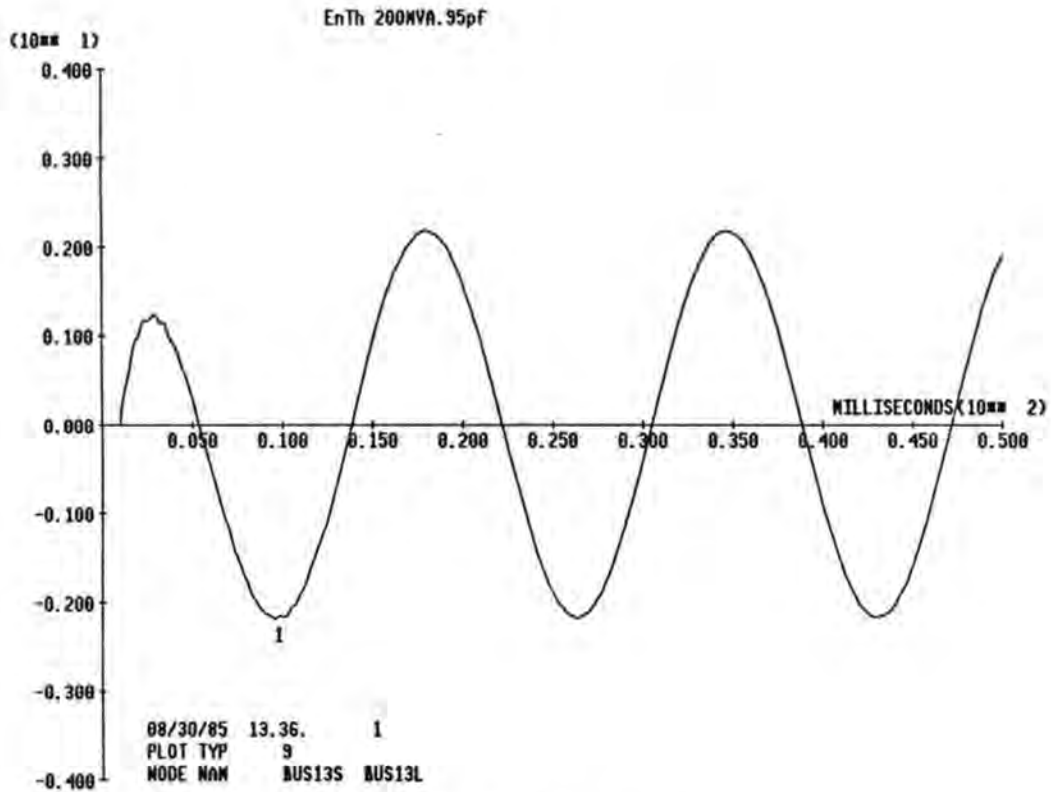

(c) Switch current.

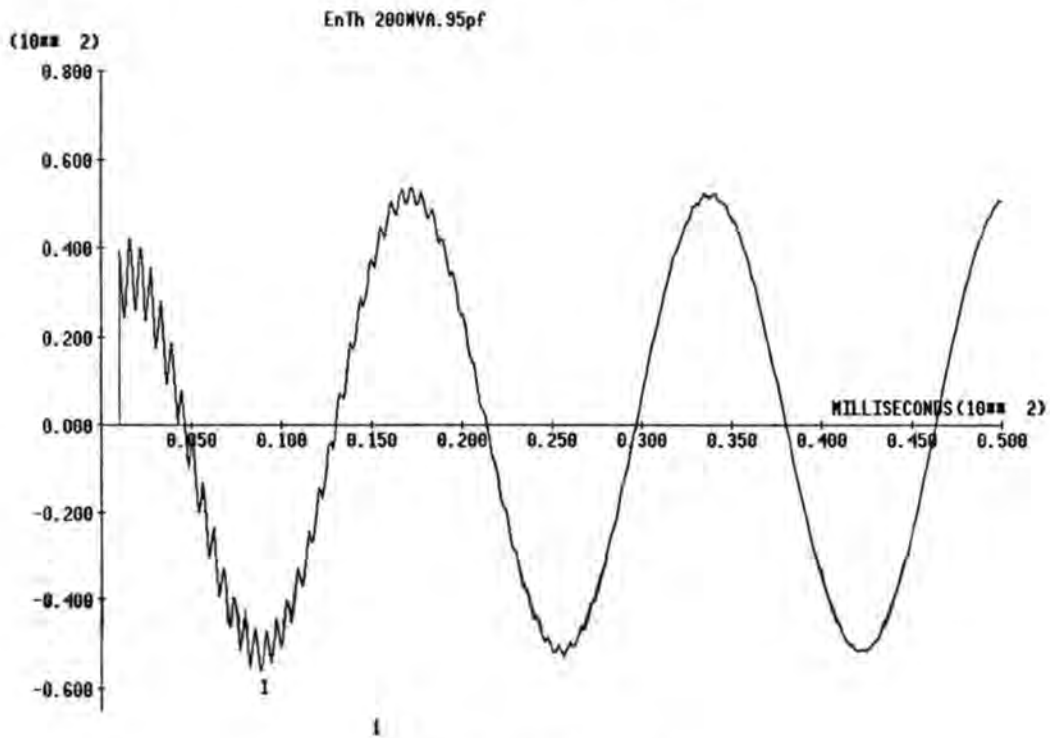

(d) Bus 13L voltage.

Figure 3.11: (continued).

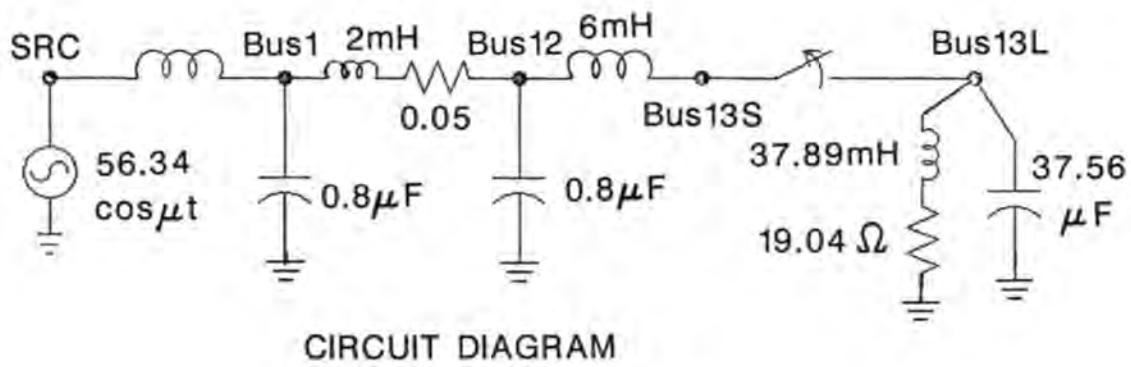

(a) Circuit diagram.

Figure 3.12: Energization of compensated .8 pf load.

```

BEGIN NEW DATA CASE
C .....Figure 3.12(b).....
C Energization of an RL load with more detailed source model
C ----dt<---tmax
   50.E-6 50.E-3
C -Iprnt<--Iplot<-Idoubl<-KssOut<-MaxOut          <---Icat
   15      1      0      0      0                    0
C
C Circuit data.....
C Bus-->Bus-->Bus-->Bus--><---R<---L<---C          0
SRC   BUS1      6.          0
BUS1  BUS12     .05      2.      0
BUS1      0.8          0
BUS12     0.8          0
BUS12  BUS13S    6.          0
BUS13L   19.04 37.89        0
BUS13L   37.56          0
BLANK End of circuit data.....
C
C Switch data.....
C Bus-->Bus--><---Tclose<---Topen<---Ie          0
BUS13SBUS13L 1.E-3 9999. 0      1
BLANK End of switch data.....
C
C Source data.....
C Bus--><I<Amplitude<Frequency<---T0;Phi0<---0=Phi0  <---Tstart<---Tstop
14SRC      56.34      60.      0      0.      -1. 9999.
BLANK End of source data.....
C
C Nodal Output Request Data.....
C Bus-->Bus-->Bus-->Bus-->Bus-->Bus-->Bus-->Bus-->Bus-->Bus-->Bus-->Bus-->
SRC   BUS13L
BLANK End of output requests.....
C
C Plot request Data.....
C _____Graph type: 4(volts) 8(branch volts) 9(currents)
C : _____Units: 1(deg) 2(cyc) 3(sec) 4(msec) 5(microsec)
C :: _____Units per inch
C :: _____Plot starting time
C :: _____Plot stopping time
C :: _____Value at bottom of vertical axis (optional)
C :: _____Value at top of vertical axis (optional)
C VV<-|<-|<-|<---|<---|<---|<---|Bus-->Bus-->Bus-->Bus-->Heading-->Vert axis-->
  194 5. 0.0 50. -4. 4.BUS13SBUS13L      EnTh 200MVA.8pf Kamps
  144 5. 0.0 50.      BUS13L              EnTh 200MVA.8pf KVolts
BLANK End of Plot Request Data.....
BLANK End of All Cases

```

(b) Input data.

Figure 3-12: (continued).

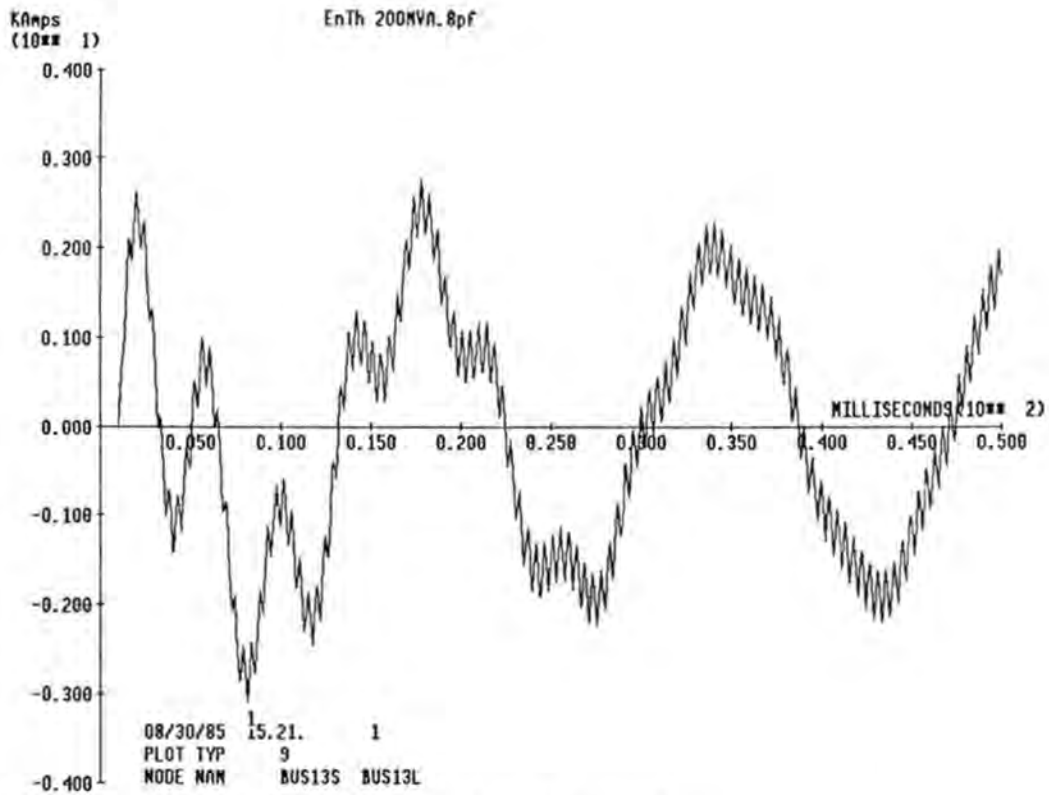

(c) Switch current.

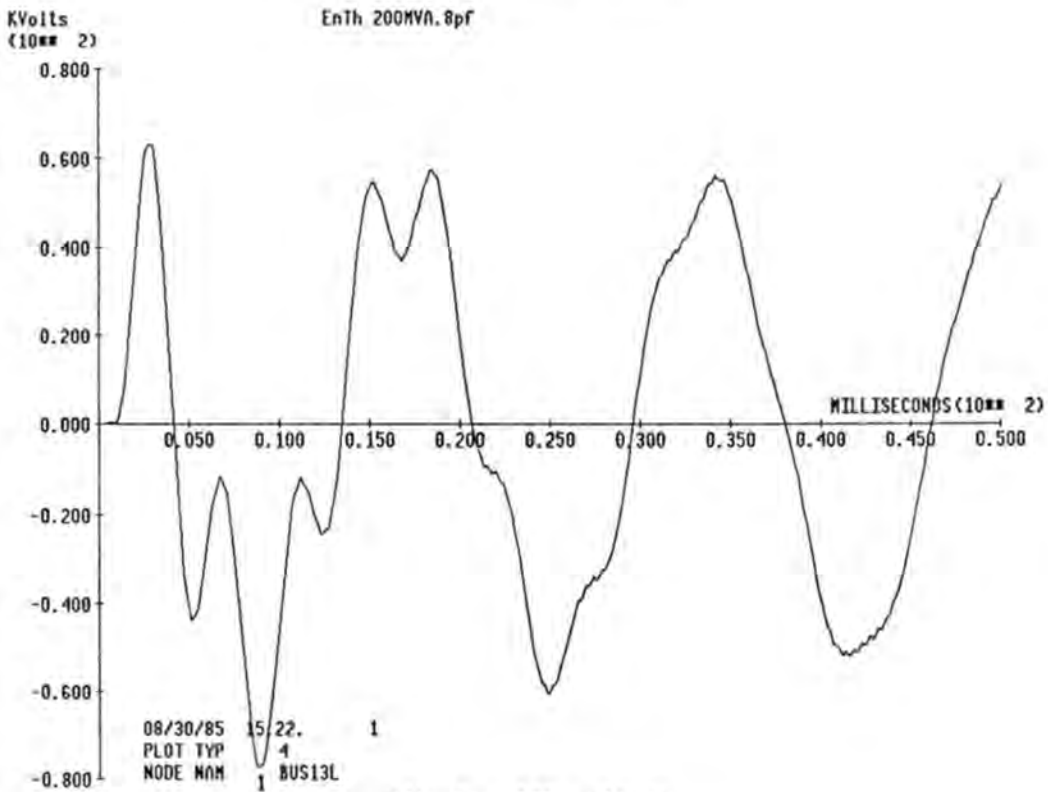

(d) Bus 13L voltage.

Figure 3.12: (continued).

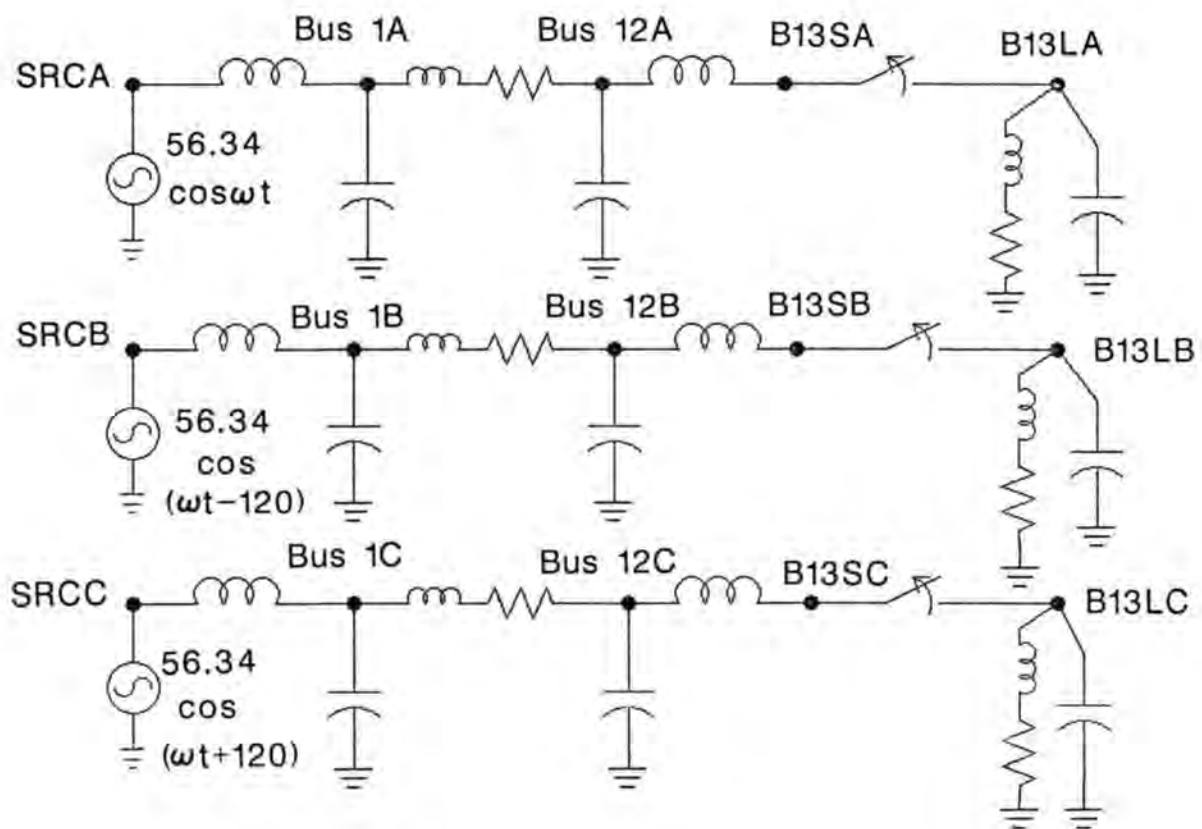

(a) Circuit diagram.

Figure 3.13: Energization of a 3-phase load.

```

BEGIN NEW DATA CASE
C .....Figure 3.13(b).....
C Energization of a 3 phase RL load
C ----dt<---tmax.....
50.E-6 50.E-3
C -Iprnt<---Iplot<-Idoubl<-KssOut<-MaxOut          <---Icat
C   15      1      0      0      0                  0
C Circuit data.....
C Bus-->Bus-->Bus-->Bus--><---R<---L<---C
SRCA  BUS1A          6.          0
SRCB  BUS1B SRCA  BUS1A          0
SRCC  BUS1C SRCA  BUS1A          0
BUS1A  BUS12A          .05  2.          0
BUS1B  BUS12B BUS1A  BUS12A          0
BUS1C  BUS12C BUS1A  BUS12A          0
BUS1A          .8          0
BUS1B          BUS1A          0
BUS1C          BUS1A          0
BUS12A          .8          0
BUS12B          BUS12A          0
BUS12C          BUS12A          0
BUS12AB13SA          6.          0
BUS12BB13SB  BUS12AB13SA          0
BUS12CB13SC  BUS12AB13SA          0
B13LA          19.04 37.89          0
B12LB          B13LA          0
B13LC          B13LA          0
          B13LA          37.56          0
          B13LB          B13LA          0
          B13LC          B13LA          0
BLANK End of circuit data.....
C
C Switch data.....
C Bus-->Bus--><---Tclose<---Topen<---Ie
B13SA B13LA  1.E-3  9999.  0          1
B13SB B13LB  1.E-3  9999.          1
B13SC B13LC  1.E-3  9999.          1
BLANK End of switch data.....
C
C Source data.....
C Bus--><I<Amplitude<Frequency<---T0:Phi0<---0=Phi          <---Tstart<---Tstop
14SRCA  56.34  60.  0  0.          -1.  9999.
14SRCB  56.34  60. -120. 0.          -1.  9999.
14SCRC  56.34  60. 120. 0.          -1.  9999.
BLANK End of source data.....
C
C Nodal Output Request Data.....
C Bus-->Bus-->Bus-->Bus-->Bus-->Bus-->Bus-->Bus-->Bus-->Bus-->Bus-->
SRCA  SRCB  SRCC  B13LA  B13LB  B13LC
BLANK End of output requests.....
C
C Plot request Data.....
C _____Graph type: 4(volts) 8(branch volts) 9(currents)
C ; _____Units: 1(deg) 2(cyc) 3(sec) 4(msec) 5(microsec)
C ; ; _____Units per inch
C ; ; ; _____Plot starting time
C ; ; ; _____Plot stopping time
C ; ; ; ; _____Value at bottom of vertical axis (optional)

```

(b) Input data.

Figure 3-13: (continued).

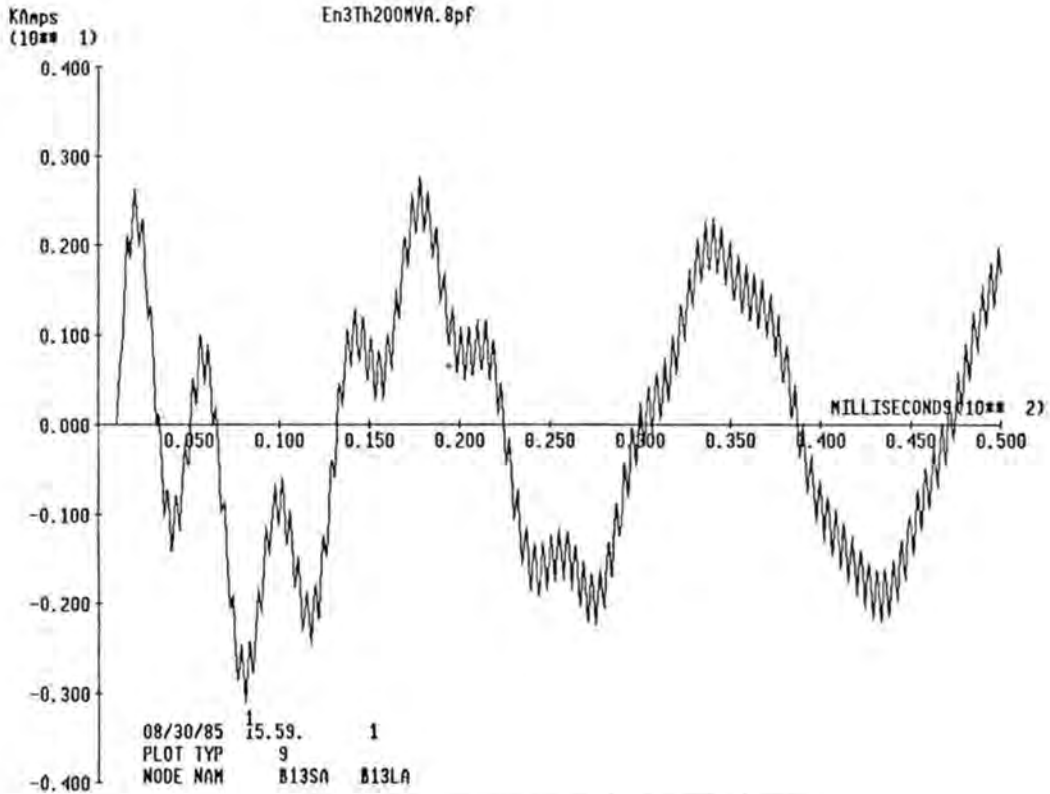

(d) B13L voltages, all three phases.

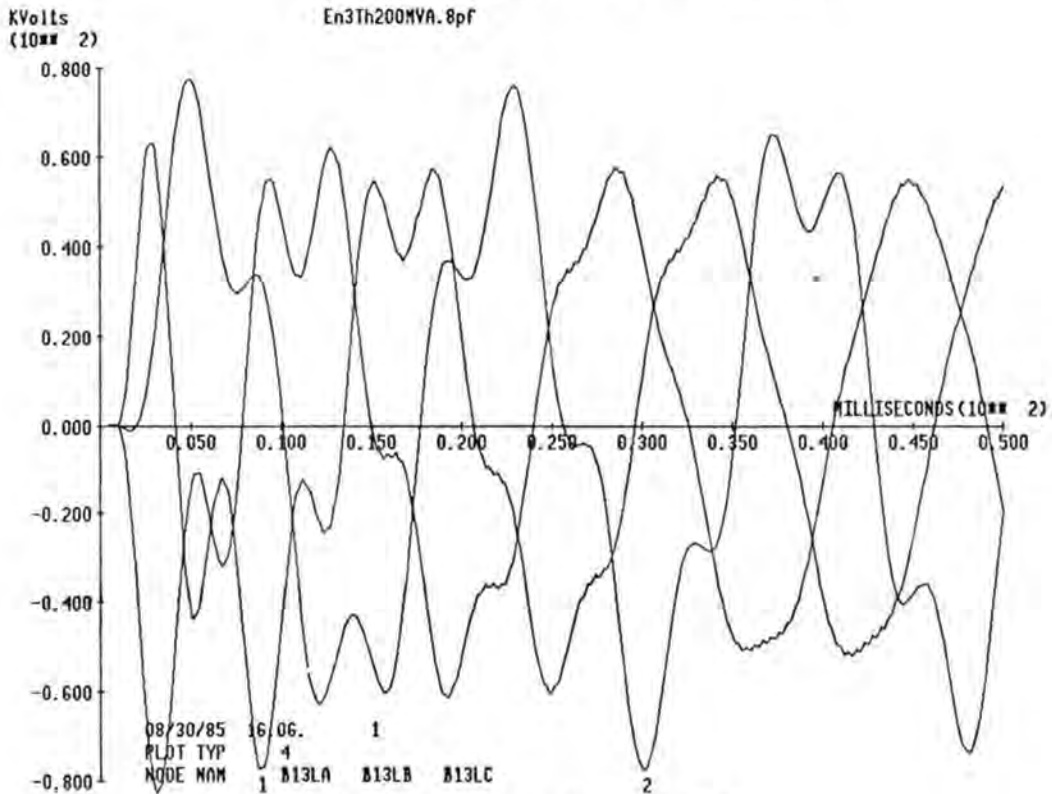

(c) Switch current, phase a.

Figure 3.13: (continued).

Load Energization Examples and Problems

As examples of simple uses of the EMTP, this section shows how to obtain, prepare and input data for several simple load energization problems. Load energization is seldom of great interest, but the ideas are easily extrapolated to other problems. The problem of interest is the energization of the load at bus 13. This study considers increasing levels of detail. It illustrates the following cases:

- Energization of a single phase load from an ideal source.
- Energization of the load with a source impedance and a PI equivalent for the 1-12 line.
- Energization of a three phase load.

Begin by calculating the necessary data. It is recommended to work in actual units: ohms, millihenries and microfarads. This workbook uses KV and KA as voltage and current units.

Calculation of the load impedances

Consider two different three phase loads.

- a) A three phase 200 MVA .95 pf purely RL load, at 69 KV. We can compute the impedance of this load if it is Y-connected from the following formula:

$$Z_Y = \frac{|V_{LL}|^2}{S_{3\phi}^*} = \frac{|KV_{LL}|^2}{MVA_{3\phi}^*}$$

This results in:

$$MVA = 200 \angle 18.19^\circ$$

$$KV_{LL} = 69$$

Therefore:

$$Z_Y = 22.61 + j 7.43 \text{ ohms.}$$

Assume that $f = 60 \text{ Hz}$. Then from here:

$$R = 22.61 \text{ ohms}$$

$$L = 19.72 \text{ mH}$$

b) A three phase 200 MVA .8 pf purely RL load compensated with a parallel connected capacitor to a power factor of .95. Using the same equation above, for the RL part of the load:

$$S = 200 \angle 36.87^\circ$$

$$R = 19.04 \text{ ohms}$$

$$L = 37.89 \text{ mH}$$

The RL part of the load absorbs:

$$Q_{RL} = 200 \sin 36.87^\circ = 120 \text{ MVAR}$$

To bring the power factor to .95 a capacitance is needed. Its value is equal to:

$$Q_{net} = \frac{200 \cos 36.87}{\tan(\cos^{-1} .95)} = 52.59 \text{ MVAR}$$

Thus, the power in the capacitor bank is:

$$Q_C = 67.41 \text{ MVAR}$$

Assume a Y connected bank. Its impedance is

$$Z_y = \frac{69^2}{67.41 \angle -90} = 70.63 \text{ ohms}$$

The net capacitance is:

$$C = 37.56 \mu\text{F.}$$

Calculation of the source voltage

A 69 KV supply implicitly assumes an RMS Line to Line voltage. However, transient analysis requires knowledge of the Line to Ground peak voltage. The following formula performs the required conversion:

$$KV_{LG}^{peak} = \frac{\sqrt{2}}{\sqrt{3}} KV_{LL}^{RMS}$$

Thus, the 69 KV source must be represented as:

$$KV_{LG}^{peak} = 56.34 KV.$$

Obtaining the source impedance

Defer the calculation of the source impedance till the next session. Assume the following information:

- a) Represent the impedance of the system as seen from bus 1 as a purely inductive impedance of 6 mH as seen from the 69 KV side.
- b) Represent the line from bus 1 to 12 as a PI equivalent circuit with the following parameters:

$$R_{ser} = .05 \text{ ohms}$$

$$L_{ser} = 2.00 \text{ mH}$$

$$C_{shunt} = .8 \text{ microF}$$

- c) Represent the transformer as an inductance of 6 mH as seen from the 69 KV side.

Ignore zero sequence effects at this time.

Examples and results

Figure 3.10(a) illustrates the first circuit studied: energization of the RL .95 pf load from an ideal source. Figure 3.10(b) gives the EMTP data listing and Figure 3.10(c) and (d) give the results of the EMTP simulation (both voltage and current).

Figure 3.11 illustrates the same studies as Figure 3.10 but with the source circuit represented in more detail. Figure 3.12 illustrates the energization of the compensated .8 pf load. Figure 3.13 illustrates the three phase model, with no attempt made to capture zero sequence effects (e.g., the system represented as three out of phase sources, each connected to the load through uncoupled impedances).

Problem 3.4: Prepare the miscellaneous data lines to perform the following simulations:

- a) A lightning study, where the item of interest is peak overvoltage magnitudes. Describe inductors in mH and capacitors in μF .
- b) An energization study, where the objective is to obtain plots of peak overvoltages and currents. Describe inductors and capacitors in ohms.
- c) A ferroresonance study, where the objective is to capture accurately all harmonics up to the 25th. Use mH, μF .

C Miscellaneous Data

C

C ----dt<---tmax<---Xopt<---Copt

C^.....^.....^.....^

C

C -Iprnt<--Iplot<-Idoubl<-KssOut<-MaxOut

<---Icat<-Nenerg

C^.....^.....^.....^.....^

.....^.....^

Problem 3.5: In the space below, enter the information required to represent the following branches between "BUS1" and "BUS2". Assume that both XOPT and COPT are zero:

- a) A capacitance whose impedance at 60 Hz is 50 ohms.
- b) An RL load that has a 60 Hz pu impedance of .2 at 60 degrees (inductive), on a 100 MVA system base, 69 KV voltage base. Use actual units.
- c) A delta-connected three phase RL load, 50 MVA, 230 KV, .85 pf, with one corner of the delta grounded.

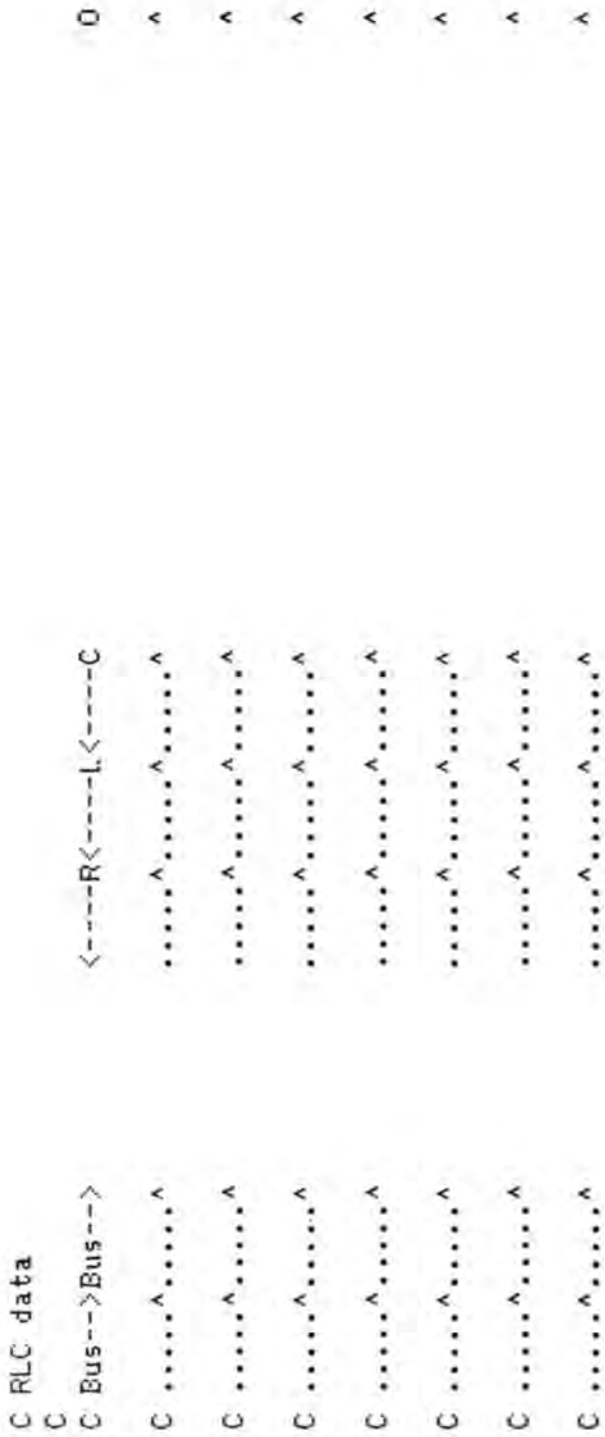

Problem 3.6: Represent the following switches:

- a) A switch between "BUS1" and ground that closes at .01 seconds.
- b) A switch between "BUS1" and "BUS2" that is closed under steady state conditions and opens at the first zero current crossing after $t = .01$. Ask for the current through this switch.
- c) A switch between "BUS1" and "BUS2" that closes at $t = .01$ and opens at $t = .02$ without waiting for a zero current crossing. Ask for the voltage across this switch.

```

C Switch data
C Bus-->Bus--><---Tclose<---Topen<-----Ie
C .....^.....^.....^.....^.....^.....^.....^
C .....^.....^.....^.....^.....^.....^.....^
C .....^.....^.....^.....^.....^.....^.....^
C .....^.....^.....^.....^.....^.....^.....^

```

Problem 3.7: Represent the following sources:

- a) A 60 Hz sinusoidal voltage source with a peak amplitude of 137 volts. The source is present under steady state conditions.
- b) A 60 Hz cosinusoidal current source with a RMS value of 10A. The source is present under steady state conditions.
- c) A set of three voltage sources to model the Line to Ground voltage of a 3-phase ideal generator, 230KV line to line RMS. The sources are first applied at $t = 0^+$.

```

C Source Data
C
C 11: Step
C 12: Ramp with rise time to "Amplitude" at time "T0", constant thereafter
C 13: Ramp with decay to "A1" at time "T1"
C 14: Amplitude * cos(2 pi f t + T0:Phi0)
C     "T1" not used. IF A1=0 then Phi0 in radians, ELSE T0 in seconds.
C 15: Amplitude * (exp(alpha t) - exp(beta t))
C     "alpha" is entered in "Frequency" field, "beta" in "T0:Phi0" field
C
C Bus--><I<Amplitude<Frequency<--T0:Phi0<-----A1<-----T1><---Tstart<----Tstop
C .....^..^.....^.....^.....^.....^.....^.....^.....^.....^.....^.....^
C .....^..^.....^.....^.....^.....^.....^.....^.....^.....^.....^.....^
C .....^..^.....^.....^.....^.....^.....^.....^.....^.....^.....^.....^
C .....^..^.....^.....^.....^.....^.....^.....^.....^.....^.....^.....^
C .....^..^.....^.....^.....^.....^.....^.....^.....^.....^.....^.....^

```

Problem 3.8: Fill in the blanks required to request the plotting of the following quantities:

a) Two nodal voltages, "NODE1" and "NODE2", plot desired in milliseconds, from $t = 0$ to $t = .05$ seconds. Size the plot to be 10" wide.

b) The current through a switch from "BUS1A" to BUS2A". You want the plot in cycles, and the interval desired is from 1 to 3 cycles of 60 Hz. Size your plot to be 12" wide.

Assume printed output requests of all these have been made previously.

Problem 3.9: Construct the complete data file to simulate the RL energization problem in Figure 3.1. Use the following parameters:

$R = 1$ $L = 1 \text{ mH}$
 $V = 1 \text{ pu}$ (peak value)
 $f = 60 \text{ Hz.}$

Select an appropriate time step Δt and an appropriate t_{\max} .

C Miscellaneous Data

C
C ---dt<---tmax<---Xopt<---Copt

C^.....^.....^

C

C -Iprnt<--Ip lot<-Idoubl<-KssOut<-MaxOut

C^.....^.....^.....^

<---Icat<-Nenerg

.....^.....^

C RLC data		
C		0
C Bus-->Bus-->	<-----R<-----L<-----C	
C ^ ^ ^ ^ ^	
C ^ ^ ^ ^ ^	
C ^ ^ ^ ^ ^	
C ^ ^ ^ ^ ^	
C ^ ^ ^ ^ ^	
C ^ ^ ^ ^ ^	
C ^ ^ ^ ^ ^	

```

C Switch data
C
C Bus-->Bus--><---Tc lose<-----Topen<-----Ie
C .....^.....^.....^.....^.....^
C .....^.....^.....^.....^.....^
C .....^.....^.....^.....^.....^
C .....^.....^.....^.....^.....^

```

0

^

^

^

^

```

C Source Data
C
C 11: Step
C 12: Ramp with rise time to "Amplitude" at time "T0", constant thereafter
C 13: Ramp with decay to "A1" at time "T1"
C 14: Amplitude * cos(2 pi f t + T0!Phi0)
C     "T1" not used. IF A1=0 then Phi0 in radians, ELSE T0 in seconds.
C 15: Amplitude * (exp(alpha t) - exp(beta t))
C     "alpha" is entered in "Frequency" field, "beta" in "T0!Phi0" field
C
C Bus--><I<Amplitude<Frequency<--T0!Phi0<-----A1<-----T1><---Tstart<----Tstop
C .....^..^.....^.....^.....^.....^.....^.....^.....^.....^.....^.....^
C .....^..^.....^.....^.....^.....^.....^.....^.....^.....^.....^.....^
C .....^..^.....^.....^.....^.....^.....^.....^.....^.....^.....^.....^
C .....^..^.....^.....^.....^.....^.....^.....^.....^.....^.....^.....^
C .....^..^.....^.....^.....^.....^.....^.....^.....^.....^.....^.....^

```

```

C Plot Data
C
C _____Graph type: 4(volts) 8(branch volts) 9(currents)
C | _____Units: 1(deg) 2(cyc) 3(sec) 4(msec) 5(microsec)
C || _____Units per inch
C || | _____Plot starting time
C || | | _____Plot stopping time
C || | | | _____Value at bottom of vertical scale .
C || | | | | _____Value at top of vertical scale .
C || | | | | _____
C VV<-|<-|<-|<-|<-|Bus-->Bus-->Bus-->Bus-->Heading----->Vert axis----->
  1
C ^^..^..^..^ .....^.....^.....^.....^.....^.....^.....^
  1
C ^^..^..^..^ .....^.....^.....^.....^.....^.....^.....^
  1
C ^^..^..^..^ .....^.....^.....^.....^.....^.....^.....^
  1
C ^^..^..^..^ .....^.....^.....^.....^.....^.....^.....^
  1
C ^^..^..^..^ .....^.....^.....^.....^.....^.....^.....^
C
C Title
C ^.....^.....^.....^.....^.....^.....^.....^.....^.....^
C
C Subtitle
O2
C ^.....^.....^.....^.....^.....^.....^.....^.....^.....^

```

Section 4

BASIC THEORY OF DISTRIBUTED TRANSMISSION LINES

To model transients in transmission lines it is necessary to use a more formalized method than a simple pi model. It is necessary to use the wave equation.

We shall consider a two-wire line and assume that it is loss-free. The effect of losses will be considered later. At this point to introduce either series resistance or shunt conductance greatly increases the complexity of the algebra without clarifying the picture.

Figure 4.1 shows a small element of a transmission line. If the line has an inductance of L henries per meter and C farads per meter, an elementary length Δx will have inductance and capacitance $L\Delta x$ and $C\Delta x$ as shown.

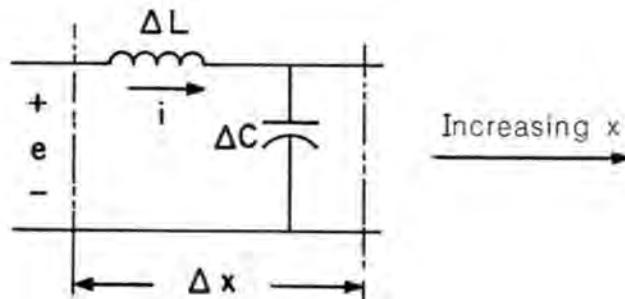

Figure 4.1: Small element of a transmission line.

The voltage across this element will be

$$-\Delta e = L'\Delta x \frac{\partial i}{\partial t}$$

which in the limit as the element shrinks in length to the infinitesimal dx can be written

$$\frac{\partial e}{\partial x} = -L' \frac{\partial i}{\partial t} \quad (4.1)$$

Partial derivatives are used because V and I are functions of both position and time.

The current to charge the elementary capacitance ΔC is given by

$$-\Delta i = C' \Delta x \frac{\partial e}{\partial t}$$

which in the limit becomes

$$\frac{\partial i}{\partial x} = -C' \frac{\partial e}{\partial t} \quad (4.2)$$

The negative signs arise from the convention being used. Figure 4.1 shows x increasing to the right. With the current flowing in the manner indicated, both V and I will diminish with increasing x . The L' and C' are per unit length.

The general solution, first given by d'Alembert, is

$$i(x,t) = f_+(x-vt) + f_-(x+vt) \quad (4.3)$$

$$e(x,t) = Z_c f_+(x-vt) - Z_c f_-(x+vt) \quad (4.4)$$

If these solutions are introduced into equations (1) and (2) they satisfy the equation when the constants Z_c and v are defined as

$$Z_c = \sqrt{\frac{L'}{C'}} \quad v = \frac{1}{\sqrt{L'C'}}$$

The physical interpretation of Z_c is that it is an impedance called the characteristic impedance or surge impedance and v is the phase velocity. The functions $f_+(x-vt)$ and $f_-(x+vt)$ can be interpreted as a wave traveling at

velocity v in a forward direction and backward direction respectively.

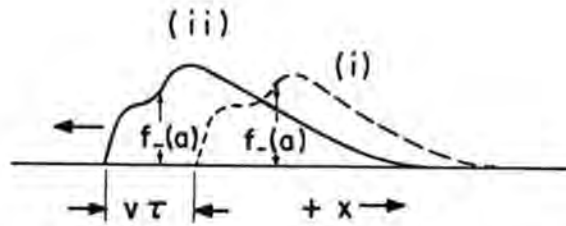

Figure 4.2: The function $f_-(x+vt)$ at (i) $t=0$, and (ii) $t=\tau$.

Consider the function $f_-(x+vt)$. At $t=0$, it has a spatial distribution $f_-(x)$ and a value at $x=a$ of $f_-(a)$. At any subsequent time, τ , it has the same value at $x = (a - v\tau)$ as it formerly had at $x=a$, which says that the voltage distribution has moved intact a distance $v\tau$ in the direction of minus x . This is illustrated in Figure 4.2. Similarly, the function $f_+(x-vt)$ represents a voltage distribution moving in the direction of plus x with a velocity v . We conclude that to satisfy the wave equation, any unbound system of charge forming a voltage distribution must be moving along the line with a velocity $v=(LC)^{-1/2}$.

What happens to these traveling waves when they reach the terminals of the line is very important in the study of transients. The effect of waves reaching the ends of a line can be interpreted as a reflection and refraction of the traveling waves. The simple way to understand this effect is to look at a simple line with a dc source and a termination resistance R_T .

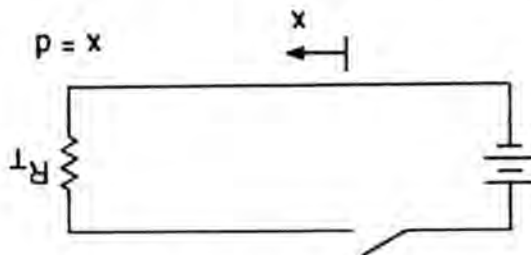

Figure 4.3: Resistance terminated line.

If we express $i(x,t)$ in equation 4.3 by a forward and backward current wave equations 4.3 and 4.4 give

$$i(x,t) = i_+(x-vt) + i_-(x+vt)$$

$$e(x,t) = Z_c i_+(x-vt) - Z_c i_-(x+vt) = e_+(x-vt) + e_-(x+vt)$$

This allows the relationship between i , and e to be expressed as

$$i^+ = \frac{e^+}{Z_c} \quad \text{and} \quad i_- = -\frac{e_-}{Z_c}$$

at the termination, $x=d$ the ratio must equal the resistance, R_T .

$$\frac{e(x=d,t)}{i(x=d,t)} = R_T$$

Using these expressions it is possible relationships between $I^+(x=d)$, $I^-(x=d)$ and $e^+(x=d)$, $e^-(x=d)$, namely:

$$i_-(d+vt) = \frac{Z_c - R_T}{Z_c + R_T} i_+(d-vt),$$

and

$$e_-(d+vt) = \frac{R_T - Z_c}{R_T + Z_c} e_+(d-vt)$$

Two obvious types of line termination are short circuit $R_T=0$ and open circuit. Consider these two extremes.

a. Short Circuit. The unique characteristic of the short circuit is that it is impossible to develop any voltage across it. Thus, when a traveling wave of voltage reaches a short circuit, the reflected voltage wave must precisely cancel out the incident wave so that the refracted wave is zero. If the incident voltage wave is e_1 and the incident current wave i_1 , the reflected voltage wave will be $-e_1$ and the reflected current wave $+i_2(=i_1)$. This is illustrated in Figure 4.4. The reflected wave of voltage annihilates the incident wave as it returns, while the reflected current wave augments the incident current wave, doubling the current flowing in the line.

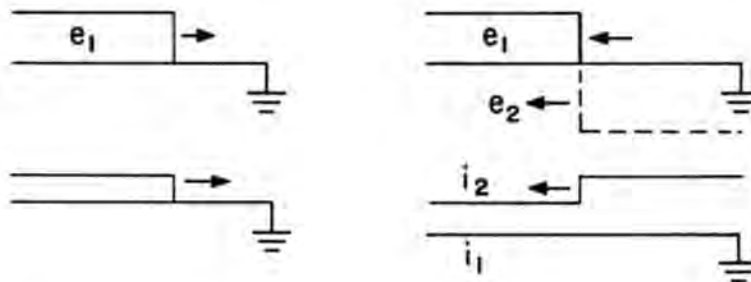

Figure 4.4: Reflection of a traveling wave from a short circuit.

Let us now examine what happens when a short circuit is applied to a transmission line fed by a voltage source, which, for the sake of simplicity, we will assume to have zero impedance and to provide a constant voltage E . Our specification of the problem implies certain boundary conditions. These are that at the short circuit the voltage is always zero, but at the source it is E at all times. To satisfy the first of these conditions when the short circuit is applied, a wave of voltage of amplitude $-E$ travels toward the source, reducing the line voltage to zero. Since this is the minus x direction, the accompany current wave is $+E/Z_0$. This is illustrated in Figure 4.5(a). When this wave reaches the source, the boundary condition there demands the initiation of a new wave of voltage $+E$, which, because of its direction, is associated with a current $+E/Z_0$. This is illustrated in Figure 4.5(b). These waves in due course reach the short circuit, whereupon the

cycle repeats 4.5(c), so that the short circuit current as seen at the fault or at the source increases in discrete steps as shown in Figures 4.5(d) and 4.5(e). At the source the effect of the short circuit is not felt until a time τ after its application. This is the time for the initial wave to travel from the fault to the source, where

$$\tau = d/v.$$

the current increases in steps of $2E/Z_0$ at intervals of 2τ .

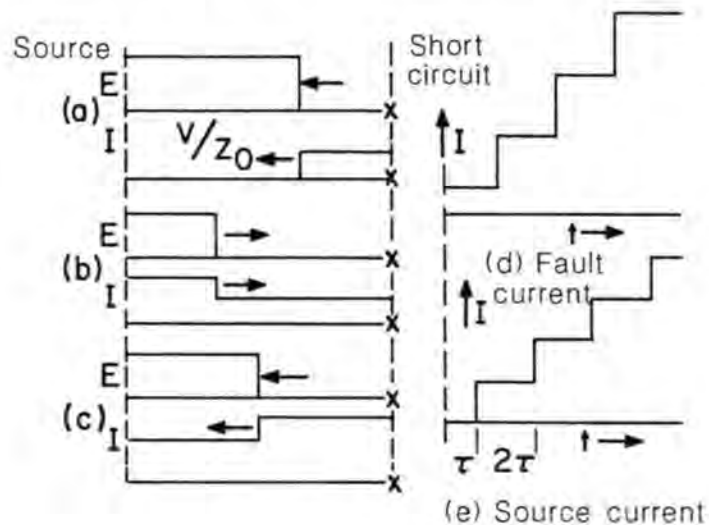

Figure 4.5: (a), (b) and (c) represent the voltage and current as a function of x for three values of t . (d) and (e) represent the current at either end as a function of t .

In an ac circuit the source voltage would vary with time. This affects what we have just discussed only to the extent that the voltage waves issuing from the source must always be such as to maintain equality between the line voltage and instantaneous source voltage whatever that may be. Between these discrete events,

when waves from the short circuit arrive at the source, the source itself is generating a continuous traveling wave by virtue of its time-varying voltage.

b. Open Circuit. An open circuit at the end of a transmission line demands that the current at that point be zero at all time. Thus when a current wave equal to I arrives at the open circuit, a current wave equal to $-I$ is at once initiated to satisfy the boundary condition. This wave will travel toward the source in company with a voltage wave of $+E$. A current wave of $-I$ incident on the open circuit would be reflected as $+I$ and be associated with $-E$. What happens when an open-circuited line is energized from a source of E volts is shown in Figure 4.6. In this situation the current disappears when the current is brought to zero at the open circuit, it reappears as voltage doubling.

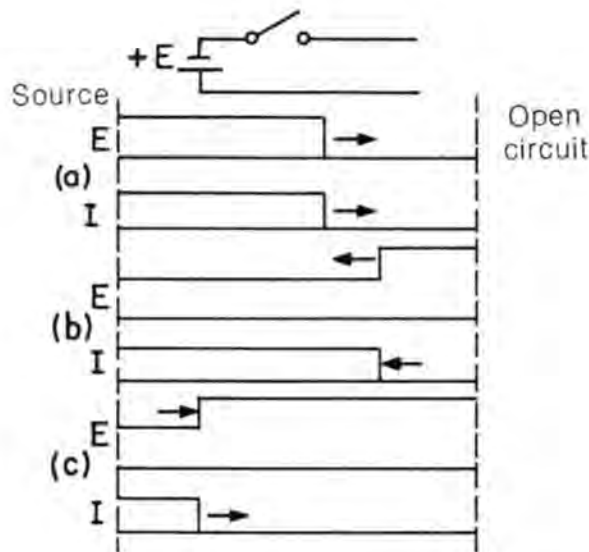

Figure 4.6: Traveling waves initiated by energizing an open-circuited line.

Section 5

THE EMTP BASIC DISTRIBUTED LINE MODELS

To understand the EMTP equivalent impedance network for a lossless distributed line, we can add and subtract equation 4.3 and 4.4.

$$e(x,t) + Z_c i(x,t) = 2Z_c f_+(x-vt) \quad (5.1)$$

$$e(x,t) - Z_c i(x,t) = 2Z_c f_-(x+vt) \quad (5.2)$$

Note that in (5.1) the expression $(e+Z_c i)$ is constant when $(x-vt)$ is constant and in (5.2) $(e-Z_c i)$ is constant when $(x+vt)$ is constant. The expressions $(x-vt) = \text{constant}$ and $(x+vt) = \text{constant}$ are called the "characteristics" of the differential equations.

Problem 5.1: You are given the following 60 Hz parameters for a distributed line:

$$\begin{aligned} z' &= .0243 + j.3483 && \text{ohms/Km} \\ y' &= j4.75 && \mu \text{ mhos/Km} \end{aligned}$$

Calculate:

$$R' =$$

$$L' =$$

$$C' =$$

$$Z_c =$$

$$\tau =$$

$$v =$$

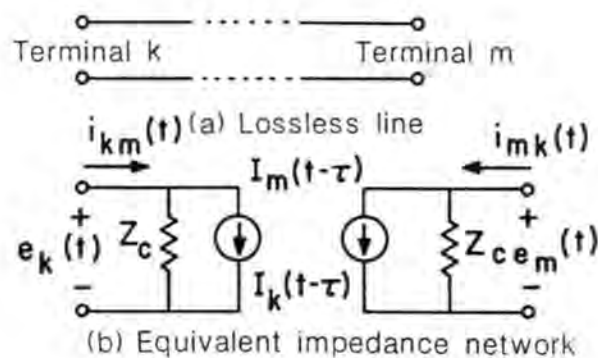

Figure 5.1: The EMTP model of a distributed line.
 (a) Lossless line. (b) Equivalent impedance network.

The significance of (5.1) may be visualized in the following way: let a fictitious observer travel along the line in a forward direction at velocity v . Then $(x-vt)$ and consequently $(e+Zi)$ along the line appears constant to the observer. If the travel time to get from one end of the line to the other is

$$\tau = d/v = d\sqrt{L'C'}$$

(d is the length of line), then the expression $(e+Zi)$ encountered by the observer when he leaves node m at time $t-\tau$ must still be the same when he arrives at node k at time t , that is

$$e(t - \tau) + Z_c i_{m,k}(t - \tau) = e(t) + Z_c (-i_{k,m}(t))$$

(currents as in Figure 5.1). From this equation follows the simple two-port equation for $i_{k,m}$

$$i_{k,m}(t) = (1/Z_c)e(t) + I_k(t - \tau)$$

similarly

$$i_{m,k}(t) = (1/Z_c)e(t) + I_m(t - \tau)$$

with equivalent current sources I_k and I_m , which are known at state t from the past history at time $t-\tau$,

$$I_k(t - \tau) = -(1/Z_c)e_m(t - \tau) - i_{mk}(t - \tau)$$

$$I_m(t - \tau) = -(1/Z_c)e_k(t - \tau) - i_{km}(t - \tau).$$

Figure 5.1 shows the corresponding equivalent impedance network, which fully describes the lossless line at its terminals. Topologically the terminals are not connected; the conditions at the other end are only seen indirectly and with a time delay τ through the equivalent current sources I .

To prepare EMTP data for a single phase distributed line, the following information is needed:

- NODE names to which the line is connected.
- Resistance R' per unit length
- L' and C' (inductance and capacitance per unit length) one
- Z_c and v (characteristic impedance and propagation velocity) of
- Z_c and τ (characteristic impedance and travel time). these
- Length

The exact format for entering this data is illustrated below:

<u>1-2</u>	<u>3-8</u>	<u>9-14</u>		<u>27-32</u>	<u>33-38</u>	<u>39-44</u>	<u>45-50</u>	<u>51-52</u>		<u>55-56</u>
"-1"	Bus1	Bus2		R'	A	B	d	Iline		Ipose
	A6	A6	12X	E6.2	E6.2	E6.2	E6.2	I2	2X	I2

BUS1, BUS2: bus names

R': series resistance per unit length

A,B: L',C' if Iline = 0

Z_c, v if Iline = 1

Z_c, τ if Iline = 2

d: length

Ipose: Not used for a single mode line.

There are several important considerations in the representation of distributed lines. These are:

- The travel time τ (whether explicitly specified or not) cannot be smaller than the time step Δt .
- The ratio of $\tau/\Delta t$ must be reasonable. Depends on your system, but values in the range of 10 to 1000 are common. Values less than 1 are not allowed. Values greater than 10000 are probably too large.
- The total resistance $R'd$ must be smaller than the characteristic impedance Z_c .
- It is best (but not necessary) that the ratio $\tau/\Delta t$ be an integer.

If any of these situations arise, you may want to think more about what you are trying to do before proceeding. For example, if τ is truly smaller than Δt you probably could use a lumped RLC branch to represent the line. If $\tau/\Delta t$ is too large, perhaps you do not need to represent the line as a distributed line since it is also likely that $t_{\max} < 2\tau$. A line from which you expect to receive no reflections during the course of the study can be represented as a pure lumped resistance with a value equal to its characteristic impedance.

As an idealized example of the energization of a single phase line, consider a single phase line with parameters corresponding to the positive sequence parameters of line i-12. Consider first the energization of this line from an ideal voltage source. The parameters for this line are:

$$R' = .0243 \text{ ohms/Km}$$

$$L' = .9238 \text{ mH/Km}$$

$$C' = .0126 \text{ micro F/Km}$$

$$d = 24.14 \text{ Km (15 miles)}$$

For illustration purposes only, begin by assuming that a PI equivalent model is adequate (it is not). Since the line is short, the 60 Hz PI equivalent can be obtained directly from the nominal PI. If this assumption is valid then:

$$R_{eq} = R' d = 0.574 \text{ ohms}$$

$$L_{eq} = L' d = 22.23 \text{ mH}$$

$$C_{eq} = C' (L/2) = .1557 \text{ microF}$$

The value of the sinusoidal source magnitude is

$$V_{\text{peak}} = 230 \times (\sqrt{2} / \sqrt{3}) \text{ KV}$$

Assume energization at exactly 1 ms after peak voltage. Figure 5.2(a) illustrates the equivalent circuit for energization of the open circuited line using a pi circuit model. Figure 5.2(b) shows the EMTP input data for this case and Figure 5.2(c) and (d) show plots of the receiving end voltage. Notice the following points:

- Voltage doubling does occur.
- The line induced oscillation is superimposed on the 60 Hz voltage.
- The waves are sinusoidal and there is no evidence of travelling waves.

Figure 5.3 illustrates the same example of energization of an open single phase line from an ideal source, but with a distributed line model used. Notice the following points:

- The waveforms of the line oscillation are square waves, not sinusoidal.
- There is voltage doubling.
- Even though energization occurs at exactly 1 ms, the receiving end voltage does not rise til $1 \text{ ms} + \tau$, where τ in this case is .082 ms.

Finally, Figure 5.4 illustrates the problem of energizing a shorted single phase line from an ideal source. Observe here:

- The fault current initially builds up as a sequence of discrete steps.
- The fault current eventually becomes a pure sinusoidal steady state current with a decaying unidirectional component.

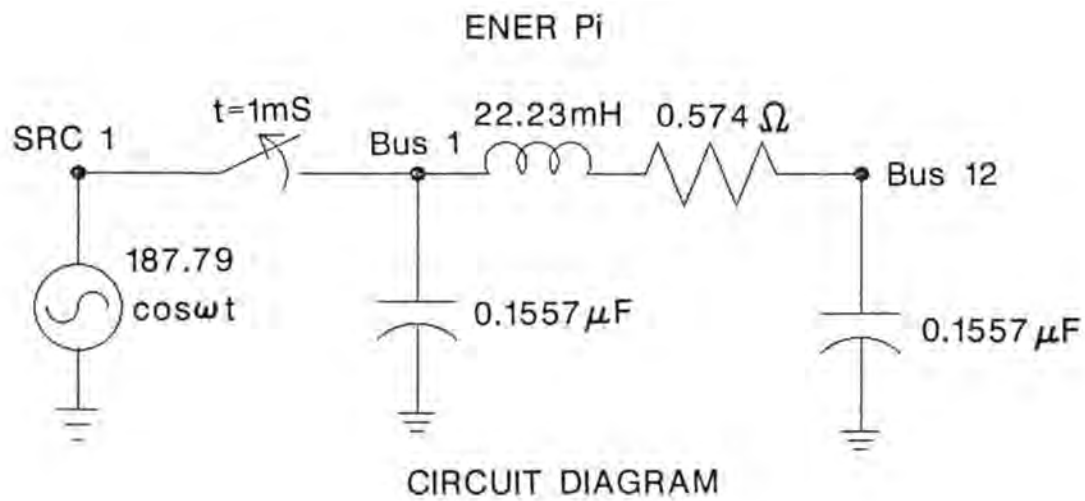

Figure 5.2: Energization of the positive sequence 60 Hz the equivalent of an open 15 mile 230 KV line using a PI equivalent model.

```

BEGIN NEW DATA CASE
C ----- Fig. 5.2(b) -----
C Energization of a 15 MILE line from an ideal voltage source .
C single phase EQUIVALENT PI model and ideal voltage source .
C ----dt<---tmax<----->
10.E-6 2.5E-3
C -Iprnt<--Iplot<-Idoubl<-KssOut<-MaxOut <---Icat
15 1 0 0 0 2
C
C .....Circuit data.....
C Bus-->Bus-->Bus-->Bus--><---R<---L<---C 0
BUS1 BUS12 0.574 22.23 0
BUS1 .1557 0
BUS12 .1557 0
BLANK End of circuit data.....!
C
C .....Switch data.....
C Bus-->Bus--><---Tclose<---Topen<---Ie 0
SRC1 BUS1 1.E-3 9999. 0 0
BLANK End of switch data.....!
C
C .....Source data.....
C Bus--><I<Amplitude<Frequency<---T0<Phi0<---0=Phi0 <---Tstart<---Tstop
14SRC1 187.79 60. 0 0. -1. 9999.
BLANK End of source data.....!
C
C .....Output Request Data.....
C Bus-->Bus-->Bus-->Bus-->Bus-->Bus-->Bus-->Bus-->Bus-->Bus-->Bus-->Bus-->
BUS1 BUS12
BLANK End of output requests.....!
C Plot request Data.....
C _____Graph type: 4(volts) 8(branch volts) 9(currents) .
C | _____Units: 1(deg) 2(cyc) 3(sec) 4(msec) 5(microsec) .
C || _____Units per inch .
C || | _____Plot starting time .
C || | | _____Plot stopping time .
C || | | | .
C VV<-|<--|<--| Bus-->Bus-->Bus-->Bus-->Heading----->Vert axis----->
ZEnergize 1phase PIequiv NoLoad IdealSrc
144.25 0.0 2.5 BUS12 EnerPi Bus12 KV
1442.5 0.0 25. BUS12 EnerPi Bus12 KV
BLANK End of Plot Request.....!
BLANK End of All Cases

```

(b) Input data.

Figure 5.2: (continued).

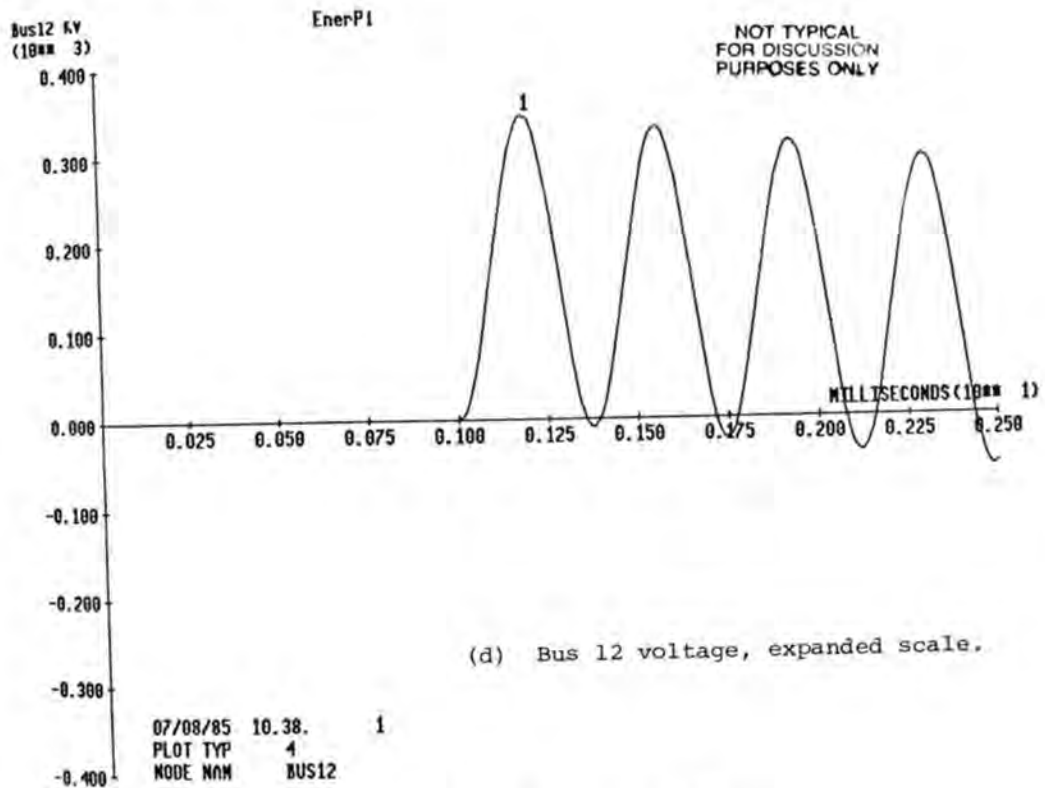
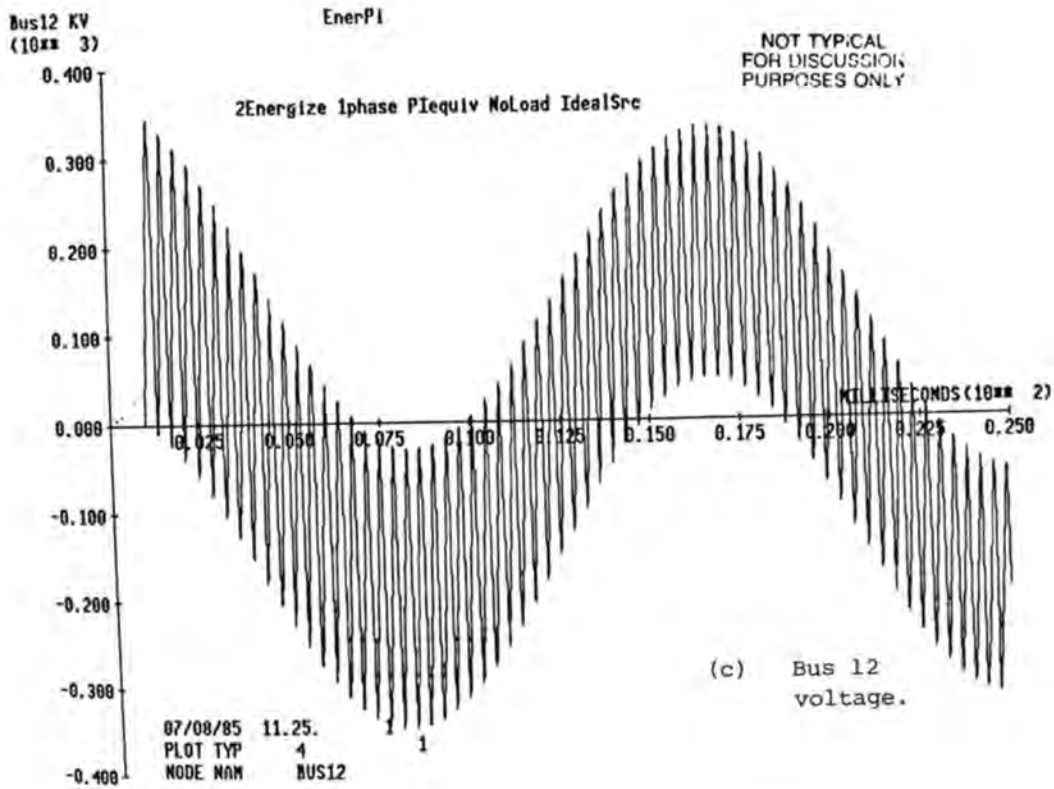
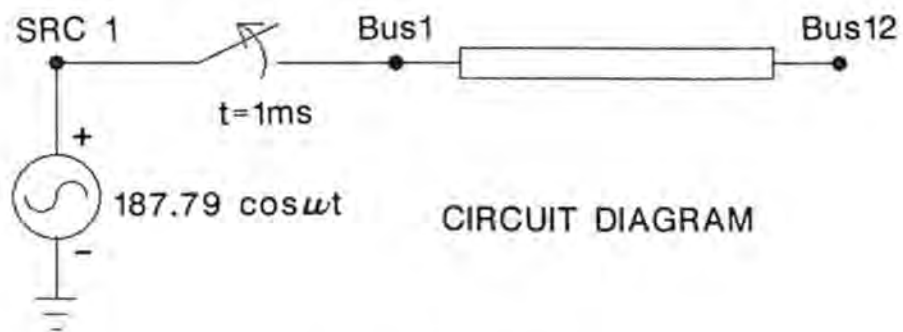

Figure 5.2: (continued).



(a) Circuit Diagram

Figure 5.3: Energization of the positive sequence of an open 15 mile distributed line from an ideal 230 KV source.

```

BEGIN NEW DATA CASE
C -----
C Energization of a 15 MILE line from an ideal voltage source .
C using actual units, single phase DISTRIBUTED LINE models. Fig. 5.3(b)
C ----dt<----tmax<----->
C 10.E-6 2.5E-3
C -Iprnt<--Iplot<-Idoubl<-KssOut<-MaxOut <---Icat
C 15 1 1 0 0 0
C
C .....Circuit data.....
C Bus-->Bus-->Bus-->Bus--><---R'<---L'<---C'<---len 0 0 0
C -1BUS1 BUS12 0.0243 .9238 .0126 24.14 0 0 0
BLANK End of circuit data.....!
C
C .....Switch data.....
C Bus-->Bus--><---Tclose<---Topen<-----Ie
C SRC1 BUS1 1.E-3 9999. 0
BLANK End of switch data.....!
C
C .....Source data.....
C Bus--><I<Amplitude<Frequency<--T0!Phi0<---0=Phi0 <---Tstart<---Tstop
C 14SRC1 187.79 60. 0 0. -1. 9999.
BLANK End of source data.....!
C
C .....Output Request Data.....
C Bus-->Bus-->Bus-->Bus-->Bus-->Bus-->Bus-->Bus-->Bus-->Bus-->Bus-->
C BUS1 BUS12
BLANK End of output requests.....!
C
C Plot request Data.....
C _____Graph type: 4(volts) 8(branch volts) 9(currents) .
C | _____Units: 1(deg) 2(cyc) 3(sec) 4(msec) 5(microsec) .
C || _____Units per inch .
C || | _____Plot starting time .
C || | | _____Plot stopping time .
C || | | | .
C VV<-!<--!<--! Bus-->Bus-->Bus-->Bus-->Heading----->Vert axis----->
C 2Energize 15mi 1phase Dist NoLoad IdealSrc
C 144.25 0.0 2.5 BUS12 EnerDist Bus12 KV
C 1442.5 0.0 25. BUS12 EnerDist Bus12 KV
BLANK End of Plot Request.....!
BLANK End of All Cases

```

(b) Input data.

Figure 5.3: (continued).

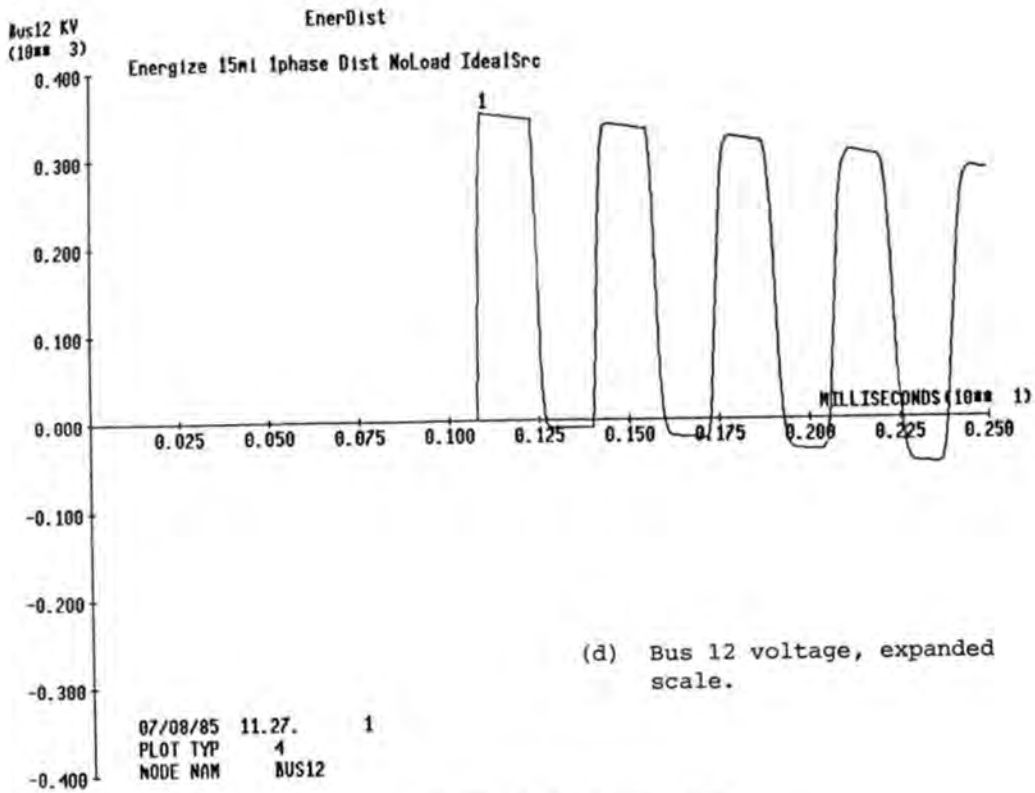
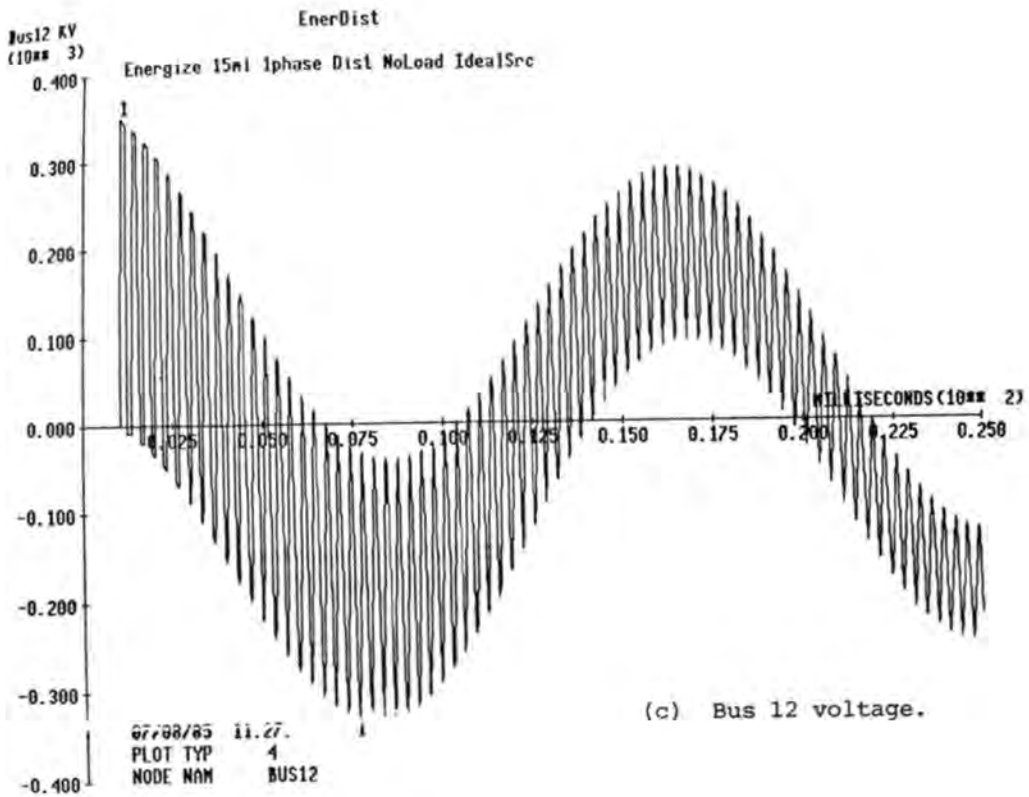
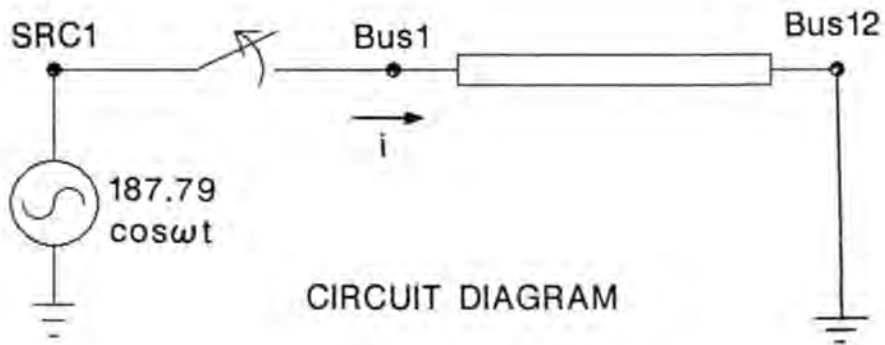

Figure 5.3: (continued).



CIRCUIT DIAGRAM

(a) Circuit Diagram

Figure 5.4: Energization of the positive sequence of a shorted 15 mile distributed line from an ideal 230 KV source.

```

BEGIN NEW DATA CASE
C ----- Fig. 5.4(b) -----
C Energization of a SHORTED 15 MILE line from an ideal voltage source
C using actual units, single phase DISTRIBUTED LINE models.
C ----dt<---tmax<----->
10.E-6 2.5E-3
C -Iprnt<---Iplot<-Idoubl<-KssOut<-MaxOut <---Icat
15 1 0 0 0 0
C
C .....Circuit data.....
C Bus-->Bus-->Bus-->Bus--><---R'<---L'<---C'<---len 0 0 0 0
-1BUS1 BUS12 0.0243 .9238 .0126 24.14 0 0 0
BLANK End of circuit data.....!
C
C .....Switch data.....
C Bus-->Bus--><---Tclose<---Topen<-----Ie 0
SRC1 BUS1 1.E-3 9999. 0 1
BUS12 -1.E-3 9999. 0 1
BLANK End of switch data.....!
C
C .....Source data.....
C Bus--><I<Amplitude<Frequency<---T0<Phi0<---0=Phi0 <---Tstart<---Tstop
14SRC1 187.79 60. 0 0. -1. 9999.
BLANK End of source data.....!
C
C .....Output Request Data.....
C Bus-->Bus-->Bus-->Bus-->Bus-->Bus-->Bus-->Bus-->Bus-->Bus-->Bus-->
BUS1 BUS12
BLANK End of output requests.....!
C Plot request Data.....
C _____Graph type: 4(volts) 8(branch volts) 9(currents)
C | _____Units: 1(deg) 2(cyc) 3(sec) 4(msec) 5(microsec)
C || _____Units per inch
C || | _____Plot starting time
C || | | _____Plot stopping time
C || | | |
C VV<-i<--!<--! Bus-->Bus-->Bus-->Bus-->Heading----->Vert axis----->
2Energize 15mi 1phase Dist Short IdealSrc
194.25 0.0 2.5 SRC1 BUS1 EnerDistShort Breaker1 KA
1942.5 0.0 25. SRC1 BUS1 EnerDistShort Breaker1 KA
BLANK End of Plot Request.....!
BLANK End of All Cases

```

(b) Input data.

Figure 5.4: (continued).

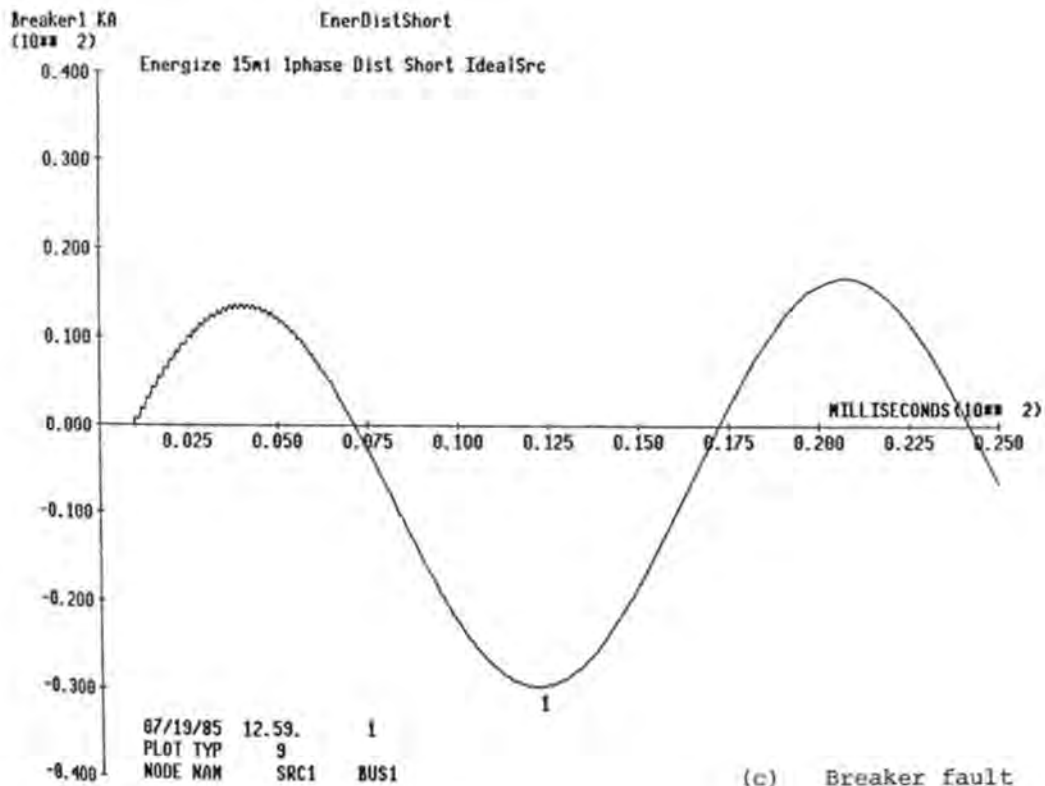

(c) Breaker fault current.

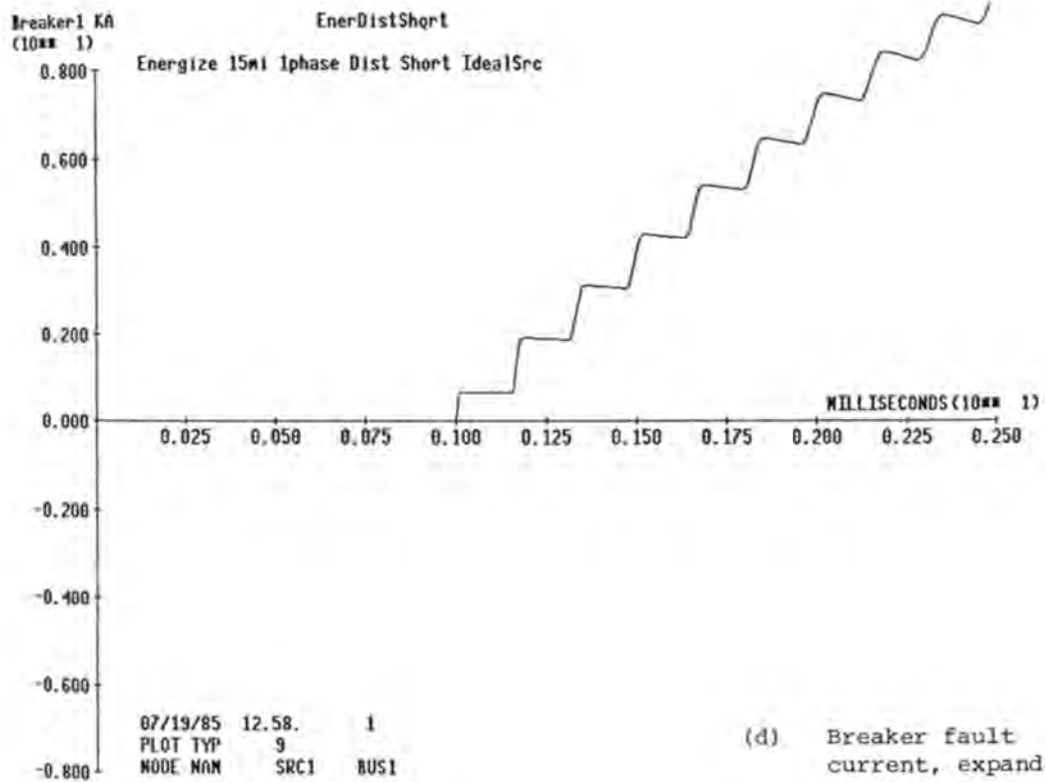

(d) Breaker fault current, expanded scale.

Figure 5.4: (continued).

Problem 5.2: You are given distributed lines with the following characteristics:

(a) $R' = .024 \text{ ohms/Km}$

$L' = 1.23 \text{ mH/Km}$

$C' = 9.08 \text{ microF/Km}$

$L = 200 \text{ Km}$

(b) $R' = .0019 \text{ ohms/Km}$

$Z_c = 295 \text{ ohms}$

$\tau = .67 \text{ ms}$

$L = 200 \text{ Km}$

(c) A 60 Hz pi equivalent equal to (Y_{shunt} is the admittance of each PI shunt leg)

$Z_{\text{ser}} = 37.2 \angle 89.7 \text{ ohms}$

$Y_{\text{shunt}} = j .000215 \text{ mhos}$

For each of these lines, prepare EMTP data to represent the line as a distributed line.

Section 6

MULTIPHASE TRANSMISSION LINES

This section helps you understand how the EMTP works, but may be skipped in a first reading.

If there is more than one conductor associated with the line, then partial differential equations describing the behavior of the line become matrix equations of the form:

$$-\frac{\partial e}{\partial x} = [R']i + [L'] \frac{\partial i}{\partial t}$$

where, for three phase systems:

$$[R'] = \begin{bmatrix} R'_{aa} & R'_{ab} & R'_{ac} \\ R'_{ba} & R'_{bb} & R'_{bc} \\ R'_{ca} & R'_{cb} & R'_{cc} \end{bmatrix} \quad [L'] = \begin{bmatrix} L'_{aa} & L'_{ab} & L'_{ac} \\ L'_{ba} & L'_{bb} & L'_{bc} \\ L'_{ca} & L'_{cb} & L'_{cc} \end{bmatrix} \quad (6.1)$$

$$-\frac{\partial i}{\partial x} = [C'] \frac{\partial e}{\partial t}$$

$$[C'] = \begin{bmatrix} C'_{aa} & C'_{ab} & C'_{ac} \\ C'_{ba} & C'_{bb} & C'_{bc} \\ C'_{ca} & C'_{cb} & C'_{cc} \end{bmatrix} \quad (6.2)$$

After a Fourier Transformation, the above equations become:

$$-\frac{\partial E}{\partial x} = [Z'] I \quad \text{where} \quad Z'_{ij} = R'_{ij} + j\omega L'_{ij} \quad (6.3)$$

$$-\frac{\partial I}{\partial x} = [Y'] E \quad \text{where} \quad Y'_{ij} = G'_{ij} + j\omega C'_{ij} \quad (6.4)$$

These last two equations can be re-written as follows:

$$\frac{\partial^2 E}{\partial x^2} = [Z'] [Y'] E \quad (6.5)$$

$$\frac{\partial^2 I}{\partial x^2} = [Y'] [Z'] I \quad (6.6)$$

A change in variables called a "modal transformation" decouples these equations. Let T_e be a modal matrix (matrix of eigenvectors) for $[Z'] [Y']$ and T_i be a modal matrix for $[Y'] [Z']$. Let:

$$E = T_e E_m \quad (6.7)$$

$$I = T_i I_m \quad (6.8)$$

Substitute in (3):

$$\frac{\partial^2 E_m}{\partial x^2} = T_e^{-1} [Z'] [Y'] T_e E_m = \Lambda E_m \quad (6.9)$$

diagonal

$$\frac{\partial^2 I_m}{\partial x^2} = T_i^{-1} [Y'] [Z'] T_i I_m = \Lambda I_m \quad (6.10)$$

diagonal

Notice that use has been made of a theorem that states that the eigenvalues of $[Z'][Y']$ are the same as those of $[Y'][Z']$. The result is thus m uncoupled modal equations, and the propagation modes are the same for both voltages and currents. The transformation matrix T_e is not unique. If T_e is a modal matrix, any matrix of the form $T_e D$ will also be a valid modal matrix (D diagonal). Furthermore, T_e and T_i are related by:

$$T_e T_i^t = D \quad (6.11)$$

Where D is diagonal and may, in particular, be the identity matrix. T_e and T_i also diagonalize equation (2).

A line can be said to be uniformly transposed (or simply transposed) if all the diagonal elements of $[L']$ and $[C']$ are equal, and all the off diagonal elements are equal. That is, both $[L']$ and $[C']$ have the form:

$$\begin{bmatrix} Z & M & M \\ M & Z & M \\ M & M & Z \end{bmatrix}$$

If a line is uniformly transposed, then we may let $T_e = T_i$. For transposed lines, this is often done. After the modal transformation, the problem is reduced to the analysis of simple scalar differential equations, each of the form:

$$- \frac{dE}{dx} = (R + j\omega L) I$$

$$- \frac{dI}{dx} = (G + j\omega C) E$$

The solution to these equations was described earlier.

Modal transformation matrices are never unique. For the case of transposed lines, a very common transformation matrix is the Karrenbauer transformation:

$$T_i = \begin{bmatrix} 1 & 1 & 1 \\ 1 & -2 & 1 \\ 1 & 1 & -2 \end{bmatrix}$$

whose inverse is:

$$T_i^{-1} = \frac{1}{3} \begin{bmatrix} 1 & 1 & 1 \\ 1 & -1 & 0 \\ 1 & 0 & -1 \end{bmatrix}$$

The Karrenbauer transformation is the default transformation used by the EMTP for transposed lines.

The Karrenbauer transformation has the virtue of being entirely real and very simple in form. In addition, if it is used for both T_e and T_i , then the resulting modal impedances and admittances are the familiar impedances and admittances that result when a symmetrical component modal transformation is performed.

For transposed lines, a user need therefore not be aware of the fact that the EMTP uses a modal transformation. If the phase matrices are given by:

$$\begin{bmatrix} Z & M & M \\ M & Z & M \\ M & M & Z \end{bmatrix}$$

then the modal matrices are given by:

$$\begin{bmatrix} Z+2M & 0 & 0 \\ 0 & Z-M & 0 \\ 0 & 0 & Z-M \end{bmatrix}$$

Once this modal transformation is applied to both the L' and the C' matrices, then the result is two distinct modal values of L' (call them L'₀' and L'₁') and two values of C'₁' (call them C'₀' and C'₁'). As in the case of the single phase line, define:

$$v_0 = \frac{1}{\sqrt{L'_0 C'_0}} \quad Z_0 = \sqrt{\frac{L'_0}{C'_0}}$$

$$v_1 = \frac{1}{\sqrt{L'_1 C'_1}} \quad Z_1 = \sqrt{\frac{L'_1}{C'_1}}$$

If the same transformation matrix has been used for i and e, then both v and Z are unique. Otherwise only the v's are unique, and Z₀ and Z₁ depend on the transformation used.

If the line is untransposed, on the other hand, it is essential to solve the so-called "eigenvalue problem" to determine the modal transformation T_i. This is a problem that in practice must be solved by computer. Fortunately, the EMTP "LINE CONSTANTS" supporting routines perform all the necessary eigenvalue calculations. As before, the modal matrix T_i is not unique. However, since the line is untransposed, it can no longer be assumed that T_e = T_i. This has the practical effect of making the characteristic impedances Z_C meaningless unless T_i is specified as well.

Internally, the EMTP represents each terminal of a multi-modal line as an equivalent circuit as shown in figure 6.1(a)(where the values of all sources and resistances are known). True modal quantities at each time step are then converted to modal quantities using T_e and T_i (Figure 6.1(b)). Modal quantities are then propagated separately and, sometime later, re-converted into current injections (Figure 6.1(c)).

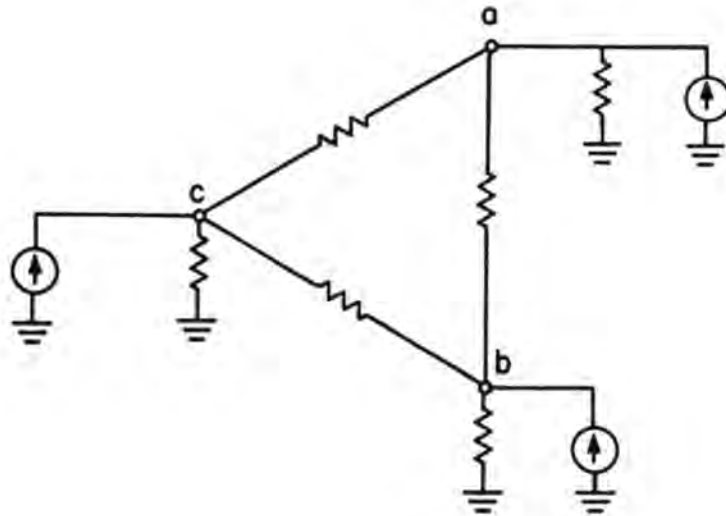

(a) Internal representation of one terminal of the line as seen from the network. Resistances are constant, current source values are known but change from one time step to the next.

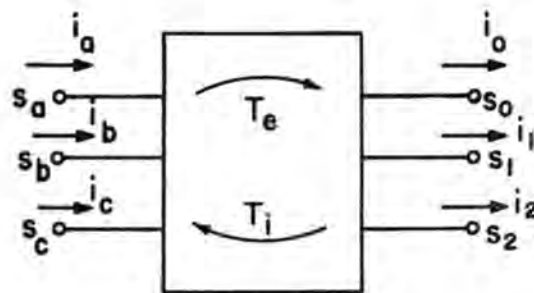

(b) Modal matrices convert phase quantities to modal and vice-verse every time step at each end of the line.

Figure 6.1: How the EMTP deals with the propagation of multimodal waves.

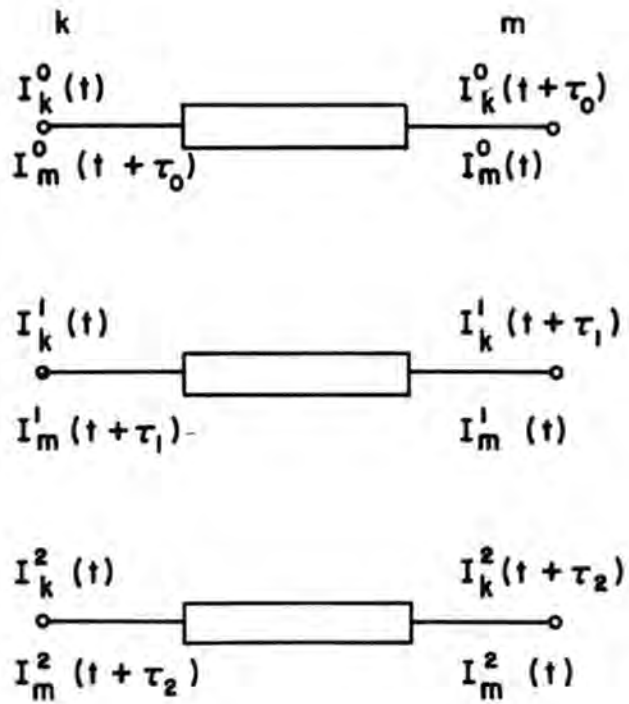

(c) Waves propagate independently and at different speeds in each mode.

Figure 6.1: (continued).

All of this discussion brings us to the final point: how to specify a multi-modal (we will assume for simplicity a three phase) line for the EMTP. The EMTP requires that you specify:

- The nodes to which the line is connected.
- The modal parameters for each node.
- The length of the line.
- Whether the line is transposed or not.

If the line is transposed, only two modes are needed, and the program assumes an implicit Karrenbauer transformation for both T_e and T_i . Thus, ordinary zero sequence and positive sequence modal data is adequate. If the line is untransposed, then three modes are needed and T_i must be specified.

The mechanics of data preparation for a three phase distributed line are:

Line #1 Node information for phase "A" and modal information for the ground mode if transposed (first mode if untransposed).

Line #2 Node information for phase "B" and modal information for line mode if transposed (second mode if not).

Line #3 Node information for phase "C". If untransposed, modal information for third mode.

If the transmission line is untransposed, these data lines are followed with three pairs of data lines of data describing the three rows of T_i .

The EMTP assumes the line is untransposed if column 56 contains a "1".

The format for the specification of line connectivity and modal information is exactly as described for the single phase line. However, if the line is untransposed this information must be followed by lines specifying T_i . For a three phase line, there are 6 data lines. These lines have the following format:

C	$T_i(1,1)$	$T_i(1,2)$	$T_i(1,3)$	
	E12.5	E12.5	E12.5	(real)
	E12.5	E12.5	E12.5	(imaginary)
C	$T_i(2,1)$	$T_i(2,2)$	$T_i(2,3)$	
	E12.5	E12.5	E12.5	(real)
	E12.5	E12.5	E12.5	(imaginary)
C	$T_i(3,1)$	$T_i(3,2)$	$T_i(3,3)$	
	E12.5	E12.5	E12.5	(real)
	E12.5	E12.5	E12.5	(imaginary)

Except in rare cases, set the imaginary parts of T_i to zero.

Figure 6.2 illustrates an example of the energization of the line from bus 1 to bus 12 with a three phase .95 pf load at bus 13. The transformer and load values are referred to the 230 kV side of the transformer. The line is assumed transposed. Notice that, because all three phases are energized at exactly the same time, the results are identical to those obtained by single phase analysis. Figure 6.3 illustrates the energization of phase a alone, leaving phases b and c energized. The two propagation velocities can now be seen. Figure 6.4 illustrates the energization of the same line but represented as an untransposed line. Finally, Figure 6.5 illustrates the energization of all three phases of the compensated .8 pf load.

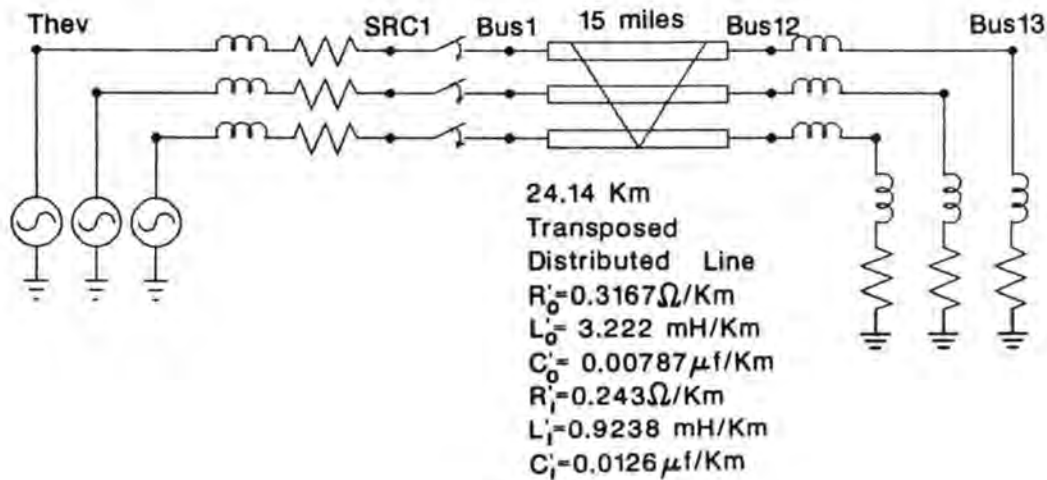

CIRCUIT DIAGRAM

(a) Circuit Diagram

Figure 6.2: Energization of all three phases of transposed line.

```

BEGIN NEW DATA CASE
C ..... Fig. 6.2(b) .....
C Energization of a 3 phase 15 MILE line connected to a xfmr and equivalent RL.
C -----dt<-----tmax<----->
  20.E-6  25.E-3
C -Iprnt<--Iplot<-Idoubl<-KssOut<-MaxOut          <---Icat
   15      1                                     2
C
C .....Circuit data.....
C Bus-->Bus-->Bus-->Bus--><----R<----L<----C
BUS12ABUS13A          70.16          0
BUS12BBUS13BBUS12ABUS13A          0
BUS12CBUS13CBUS12ABUS13A          0
BUS13A          251.2 219.1          0
BUS13B          BUS13A          0
BUS13C          BUS13A          0
THEVA SRC1A          0.714 70.68          0
THEVB SRC1B THEVA SRC1A          0
THEVC SRC1C THEVA SRC1A          0
C Bus-->Bus-->Bus-->Bus--><---R'<---L'<---C'<---len 0 0 0
-1BUS1A BUS12A          0.3167 3.222.00787 24.14 0 0 0
-2BUS1B BUS12B          0.0243 .9238 .0126 24.14 0 0 0
-3BUS1C BUS12C          0
BLANK End of circuit data.....!
C
C .....Switch data.....
C Bus-->Bus--><---Tclose<---Topen<-----Ie
SRC1A BUS1A          1.E-3 9999.          0
SRC1B BUS1B          1.E-3 9999.          0
SRC1C BUS1C          1.E-3 9999.          0
BLANK End of switch data.....!
C
C .....Source data.....
C Bus--><I<Amplitude<Frequency<---T0!Phi0<---0=Phi0          <---tstart<---Tstop
14THEVA          187.79          60.          0.          0.          -1.          9999.
14THEVB          187.79          60.          -120.          0.          -1.          9999.
14THEVC          187.79          60.          120.          0.          -1.          9999.
BLANK End of source data.....!
C
C .....Output Request Data.....
C Bus-->Bus-->Bus-->Bus-->Bus-->Bus-->Bus-->Bus-->Bus-->Bus-->Bus-->Bus-->
  BUS1A BUS12A  --
BLANK End of output requests.....!
C Plot request Data
C _____Graph type: 4(volts) 8(branch volts) 9(currents)
C | _____Units: 1(deg) 2(cyc) 3(sec) 4(msec) 5(microsec)
C || _____Units per inch
C || | _____Plot-starting time
C || | | _____Plot stopping time
C || | | |
C VV<-!<---!<---!          Bus-->Bus-->Bus-->Bus-->Heading----->Vert axis----->
  144 2. 0.0 25.          BUS12A          EnerDist3Eqload1Bus12 KV
  144 .2 0.0 2.5          BUS12A          EnerDist3!Eqload1Bus12 KV
BLANK End of Plot Request
BLANK End of All Cases

```

(b) Input data.

Figure 6.2: (continued).

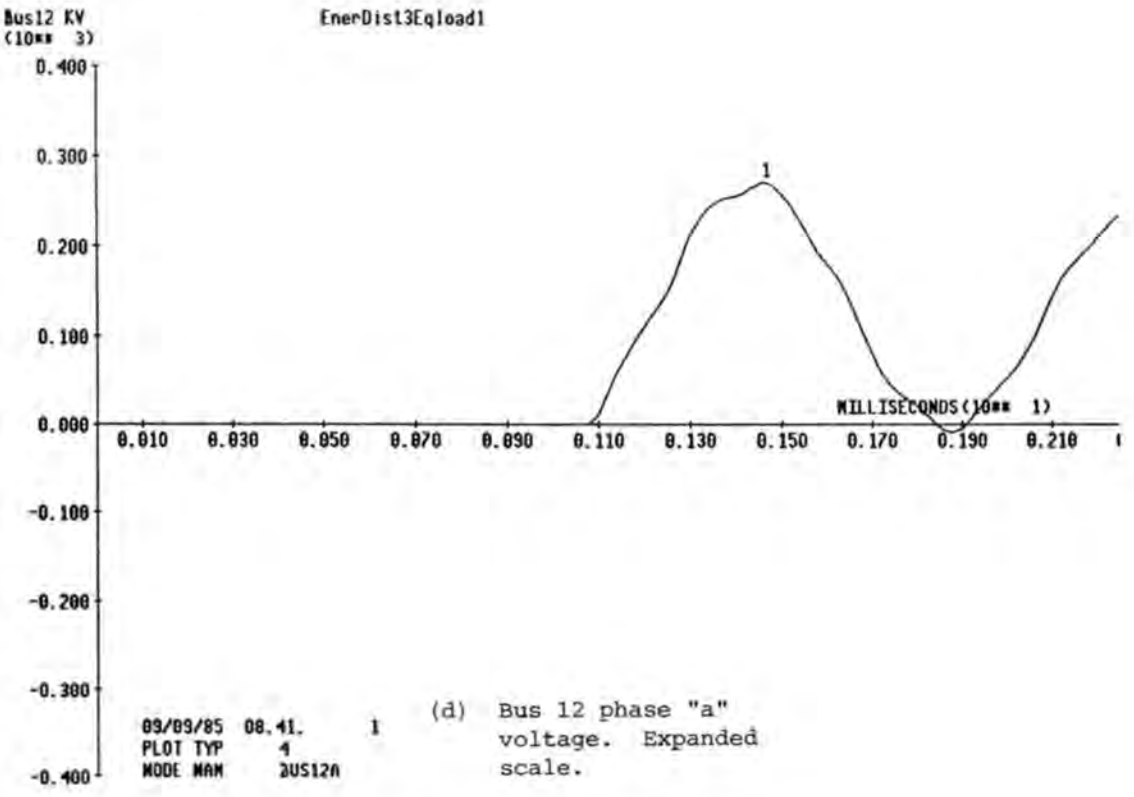
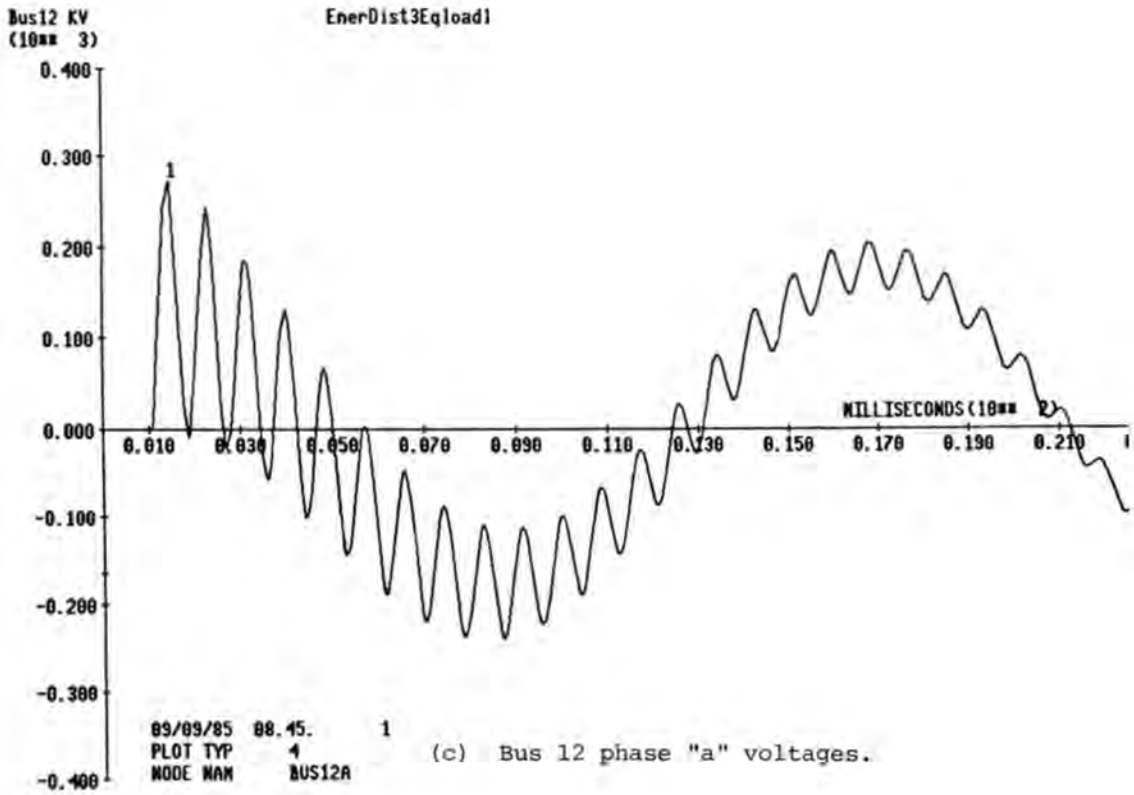
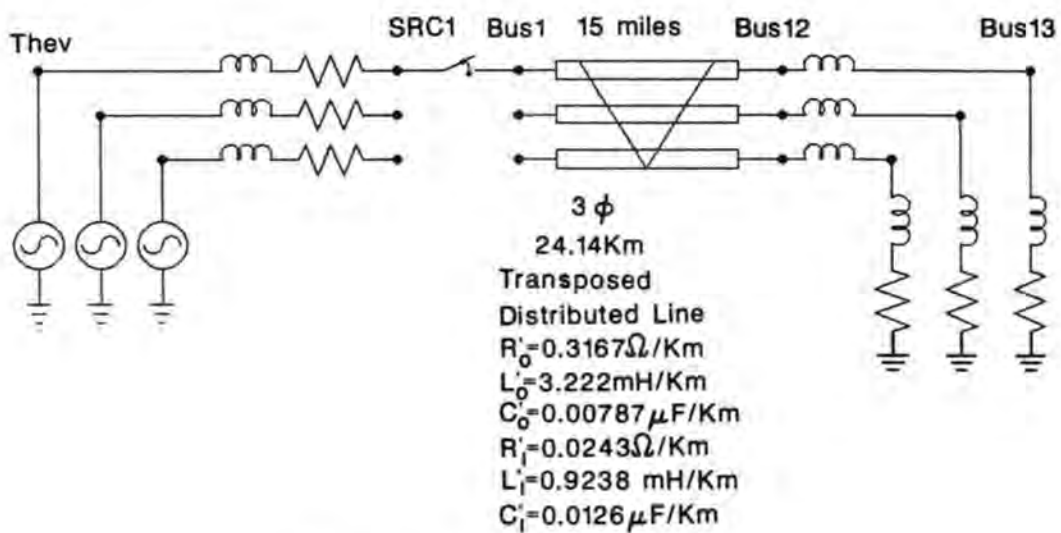

Figure 6.2: (continued).



CIRCUIT DIAGRAM

(a) Circuit Diagram.

Figure 6.3: Energization of phase "a" of three phase distributed line.

```

BEGIN NEW DATA CASE
C .....Figure 6.3(b).....
C Energization of a single phase of a three phase 15 MILE line connected to
C a transformer and an RL load
C .....
C -----dt<---tmax<----->
C 20.E-6 2.5E-3
C -Iprnt<---Iplot<---Idoubl<---KssOut<---MaxOut          <---Icat
C      15      1      0      0      0                      2
C
C .....Circuit data.....
C Bus-->Bus-->Bus-->Bus--><---R<---L<---C
BUS12ABUS13A          70.16      0
BUS12BBUS13BBUS12ABUS13A      0
BUS12CBUS13CBUS12ABUS13A      0
BUS13A          251.2 219.1      0
BUS13B      BUS13A      0
BUS13C      BUS13A      0
THEVA SRC1A          0.714 70.68      0
THEVB SRC1B THEVA SRC1A      0
THEVC SRC1C THEVA SRC1A      0
C Bus-->Bus-->Bus-->Bus--><---R'<---L'<---C'<---len 0 0 0<---Blank----->0
-1BUS1A BUS12A          0.3167 3.222.00787 24.14 0 0 0      0
-2BUS1B BUS12B          0.0243 .9238 .0126 24.14 0 0 0      0
-3BUS1C BUS12C          0
BLANK End of circuit data.....|
C
C .....Switch data.....
C Bus-->Bus--><---Yclose<---Yopen<---Ie
SRC1A BUS1A          1.E-3 9999.      0
BLANK End of switch data.....|
C
C .....Source data.....
C Bus--><I<Amplitude<Frequency<---T0!Phi0<---0=Phi0          <---fstart<--- istop
14THEVA          187.79      60.      0.      0.          -1.      9999.
14THEVB          187.79      60.      -120.      0.          -1.      9999.
14THEVC          187.79      60.      120.      0.          -1.      9999.
C peak Line to ground voltage for a 230 KV RMS line to line source is 187.79KV ;
BLANK end of source data.....|
C
C .....Output Request Data.....
C Bus-->Bus-->Bus-->Bus-->Bus-->Bus-->Bus-->Bus-->Bus-->Bus-->Bus-->
BUS1A BUS12A
BLANK End of output requests.....|
C
C Plot request Data
C _____Graph type: 4(volts) 8(branch volts) 9(currents)
C | _____Units: 1(deg) 2(cyc) 3(sec) 4(msec) 5(microsec)
C || _____Units per inch
C || | _____Plot starting time
C || | | _____Plot stopping time
C || | | |
C VV<---|<---|<---|          Bus-->Bus-->Bus-->Bus-->Heading----->Vert axis----->
  144 .2 0.0 2.5          BUS12A          EnerDist3Eqload1Bus12 KV
  144 2. 0.0 25.          BUS12A          EnerDist3Eqload1Bus12 KV
BLANK End of Plot Request
BLANK End of All Cases

```

(b) Input data.

Figure 6.3: (continued).

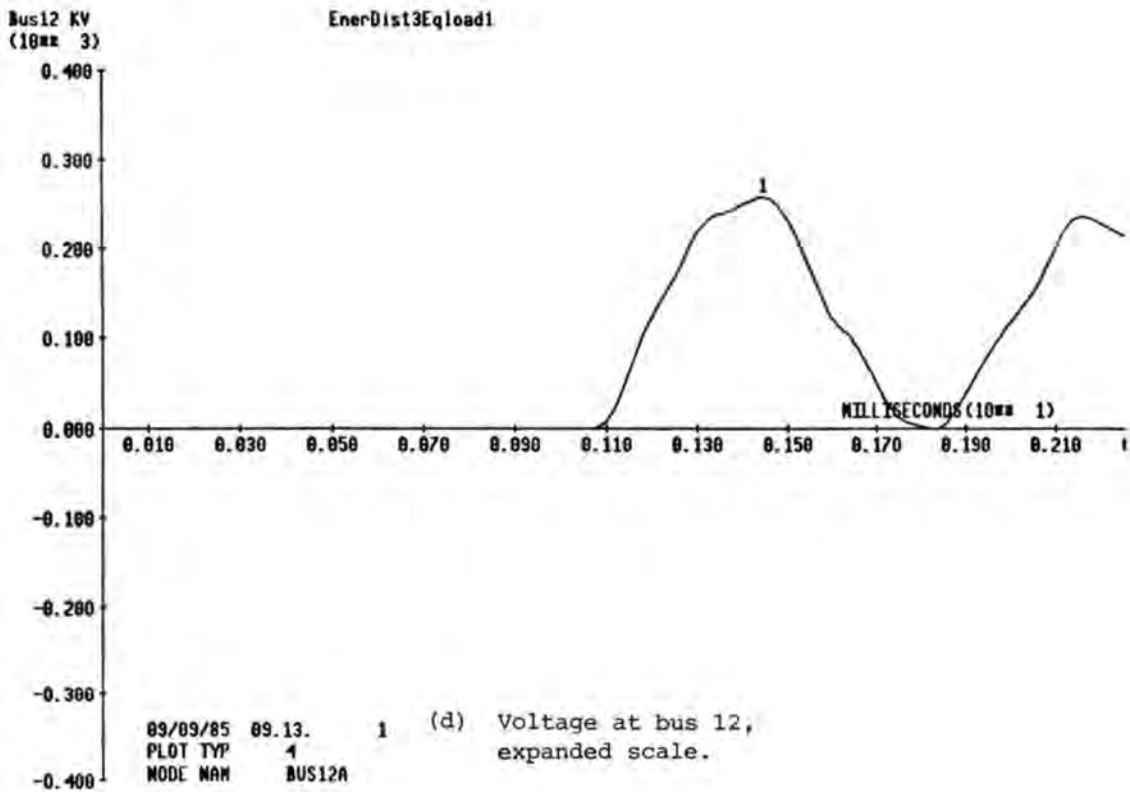
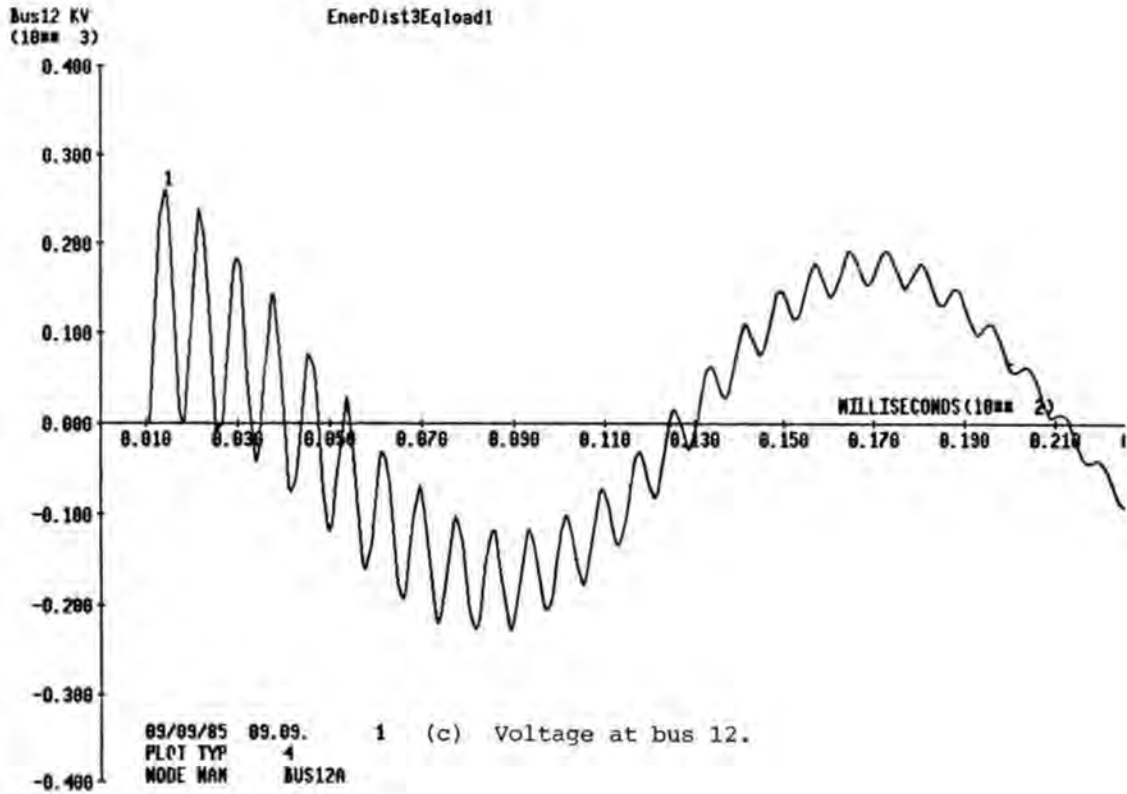
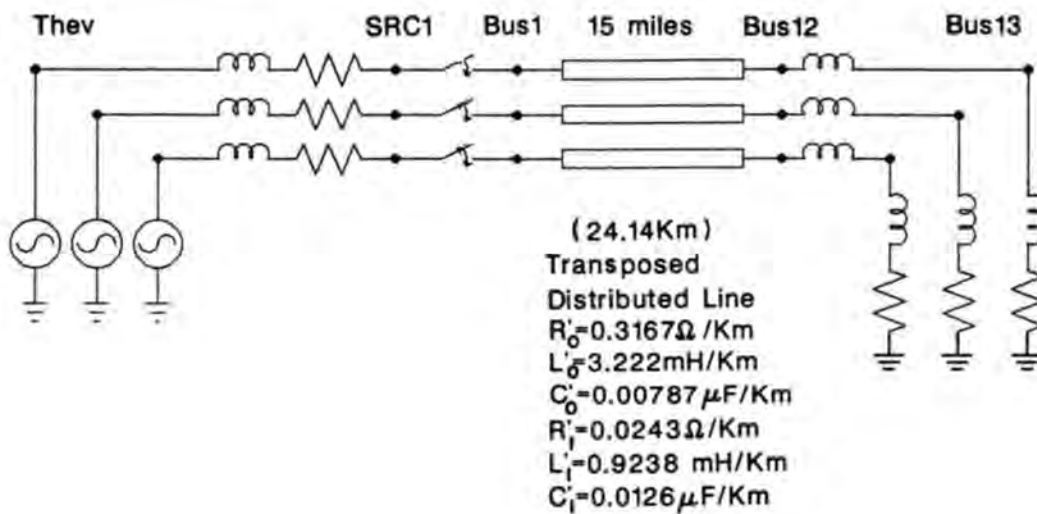

Figure 6.3: (continued).



(a) Circuit Diagram.

Figure 6.4: Energization of transposed line terminated by a transformer and an RL load using transposed distributed line models.

```

BEGIN NEW DATA CASE
C .....Figure 6.4(b).....
C Energization of an untransposed 3 phase 15 MILE line connected to a xfmr and
C an RL load
C -----dt<-----tmax<----->
C 20.E-6 2.5E-3
C -Iprnt<---Iplot<---Idoubl<---KssOut<---MaxOut          <---Icat
C      15      1      0      0      0                      2
C
C .....Circuit data.....
C Bus-->Bus-->Bus-->Bus--><---R<---L<---C              0
BUS12ABUS13A          70.16          0
BUS12BBUS13BBUS12ABUS13A          0
BUS12CBUS13CBUS12ABUS13A          0
BUS13A          251.2 219.1          0
BUS13B      BUS13A          0
BUS13C      BUS13A          0
THEVA SRC1A          0.714 70.68          0
THEVB SRC1B THEVA SRC1A          0
THEVC SRC1C THEVA SRC1A          0
C Bus-->Bus-->Bus-->Bus--><---R'<---L'<---C'<---len 0 0 0
-1BUS1A BUS12A          0.3140 3.196,00793 24.14 0 0 3
-2BUS1B BUS12B          0.0247 1.015 .0115 24.14 0 0 3
-3BUS1C BUS12C          0.0239 .8288 .0137 24.14 0 0 3
C -----Ti<-----Tj<-----Tj
0.59521098 -0.70710678 -0.41240852
0.00000000 0.00000000 0.00000000
0.53985903 0.00000000 0.81230439
0.00000000 0.00000000 0.00000000
0.59521098 0.70710678 -0.41240852
0.00000000 0.00000000 0.00000000
BLANK End of circuit data.....
C
C .....Switch data.....
C Bus-->Bus--><---Tclose<---Topen<---Ie              0
SRC1A BUS1A      1.E-3 9999. 0
SRC1B BUS1B      1.E-3 9999. 0
SRC1C BUS1C      1.E-3 9999. 0
BLANK End of switch data.....
C
C .....Source data.....
C Bus--><I<Amplitude<Frequency<---T0<Phi0<---0=Phi0      <---Tstart<---Tstop
14THEVA      187.79      60.      0.      0.      -1. 9999.
14THEVB      187.79      60.     -120.     0.      -1. 9999.
14THEVC      187.79      60.      120.     0.      -1. 9999.
BLANK End of source data.....
C
C .....Output Request Data.....
C Bus-->Bus-->Bus-->Bus-->Bus-->Bus-->Bus-->Bus-->Bus-->Bus-->Bus-->
BUS1A BUS12A
BLANK End of output requests.....
C Plot request Data
C _____Graph type: 4(volts) 8(branch volts) 9(currents)
C | _____Units: 1(deg) 2(cyc) 3(sec) 4(msec) 5(microsec)
C || _____Units per inch
C || | _____Plot starting time
C || | | _____Plot stopping time
C || | | |
C VV<---i<---| Bus-->Bus-->Bus-->Bus-->Heading----->Vert axis----->

```

(b) Input data.

Figure 6.4: (continued).

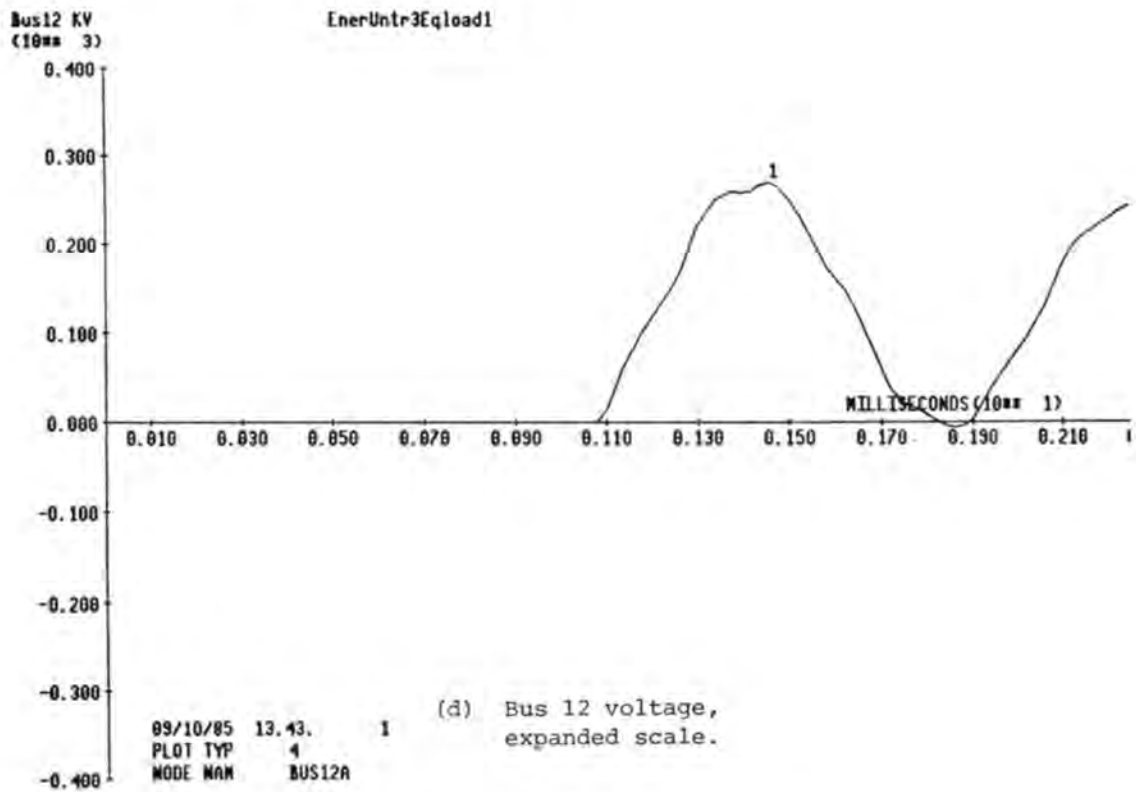
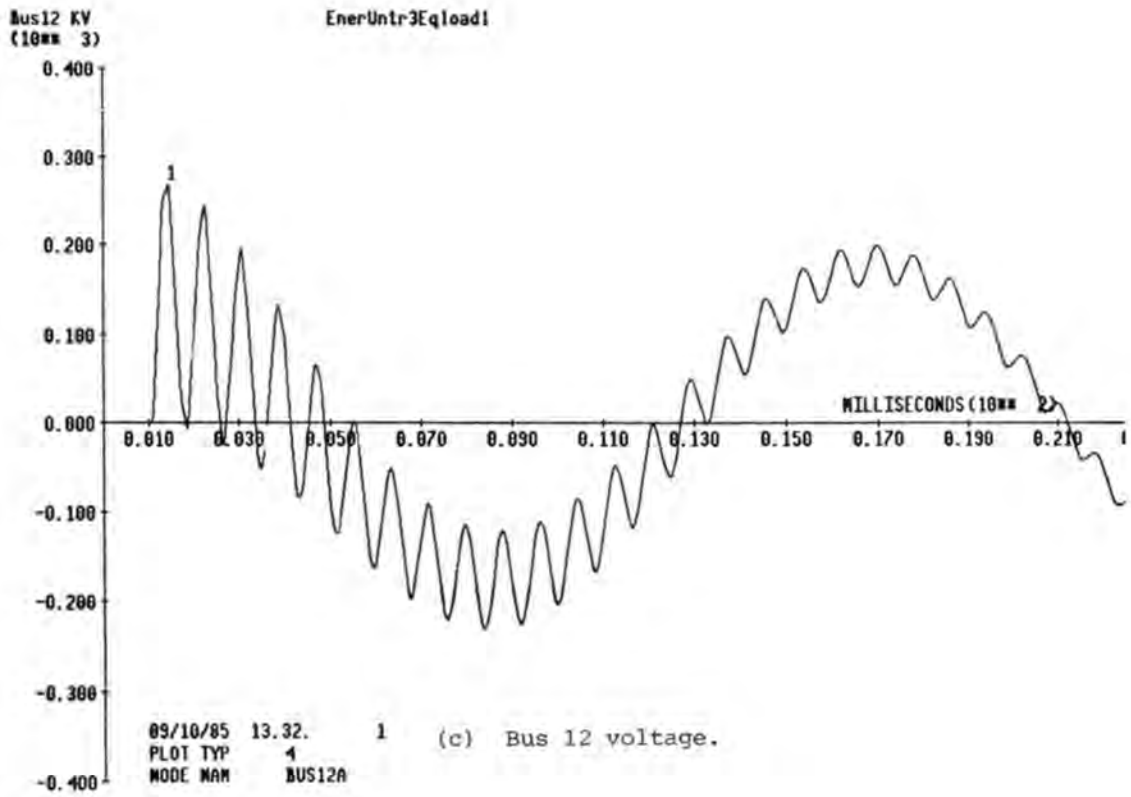
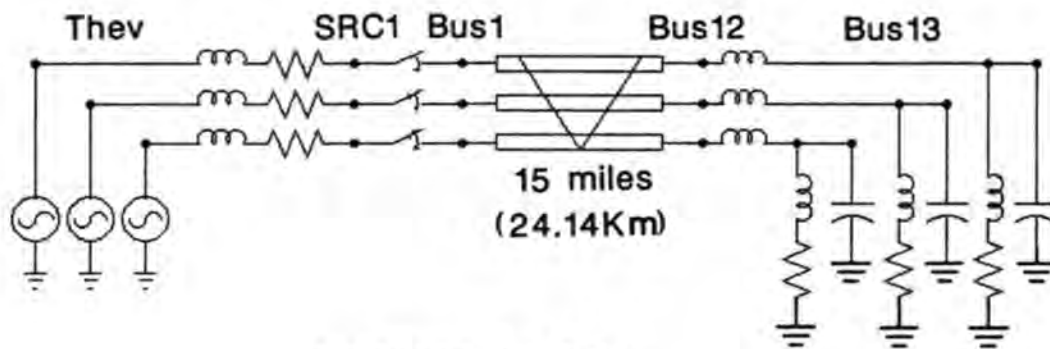

Figure 6.4: (continued).



CIRCUIT DIAGRAM

(a) Circuit Diagram.

Figure 6.5: Energization of transposed line connected to compensated load.

```

BEGIN NEW DATA CASE
C ..... Figure 6.5(b) .....
C Energization of a 3 phase 15 MILE line connected to a xfmr and RLC load
C -----dt<---tmax<----->
  20.E-6  2.5E-3
C -Iprnt<--Iplot<-Idoubl<-KssOut<-MaxOut          <---Icat
   15      1                                2
C
C .....Circuit data.....
C Bus-->Bus-->Bus-->Bus--><---R<---L<---C          0
  BUS12ABUS13A                                70.16      0
  BUS12BBUS13BBUS12ABUS13A                    0          0
  BUS12CBUS13CBUS12ABUS13A                    0          0
  BUS13A                                211.6 421.0      0
  BUS13B      BUS13A                        0          0
  BUS13C      BUS13A                        0          0
           BUS13A                                3.353      0
           BUS13B      BUS13A                    0          0
           BUS13C      BUS13A                    0          0
  THEVA SRC1A                                0.714 70.68      0
  THEVB SRC1B THEVA SRC1A                    0          0
  THEVC SRC1C THEVA SRC1A                    0          0
C Bus-->Bus-->Bus-->Bus--><---R'<---L'<---C'<---len 0 0 0<-----Blank----->0
-1BUS1A BUS12A                                0.3167 3.222.00787 24.14 0 0 0      0
-2BUS1B BUS12B                                0.0243 .9238 .0126 24.14 0 0 0      0
-3BUS1C BUS12C                                0          0          0          0
BLANK End of circuit data.....|
C
C .....Switch data.....
C Bus-->Bus--><---Tclose<---Topen<-----Ie          0
  SRC1A BUS1A      1.E-3  9999.  0          0          0
  SRC1B BUS1B      1.E-3  9999.  0          0          0
  SRC1C BUS1C      1.E-3  9999.  0          0          0
BLANK End of switch data.....|
C
C .....Source data.....
C Bus--><I<Amplitude<Frequency<---T0!Phi0<---0=Phi0      <---Tstart<---Tstop
14THEVA      187.79      60.      0.      0.      -1.      9999.
14THEVB      187.79      60.     -120.     0.      -1.      9999.
14THEVC      187.79      60.     120.     0.      -1.      9999.
BLANK End of source data.....|
C
C .....Output Request Data.....
C Bus-->Bus-->Bus-->Bus-->Bus-->Bus-->Bus-->Bus-->Bus-->Bus-->Bus-->
  BUS1A BUS12A
BLANK End of output requests.....|
C Plot request Data
C -----Graph type: 4(volts) 8(branch volts) 9(currents)
C ; -----Units: 1(deg) 2(cyc) 3(sec) 4(nsec) 5(microsec)
C ; ; -----Units per inch
C ; ; ; -----Plot starting time
C ; ; ; -----Plot stopping time
C ; ; ; ;
C VV<--!<---!<---!      Bus-->Bus-->Bus-->Bus-->Heading----->Vert axis----->
  144 .2 0.0 2.5      BUS12A      EnerDist3Eload3Bus12 KV
  144 2. 0.0 25.      BUS12A      EnerDist3Eload3Bus12 KV
BLANK End of Plot Request
BLANK End of All Cases

```

(b) Input data.

Figure 6.5: (continued).

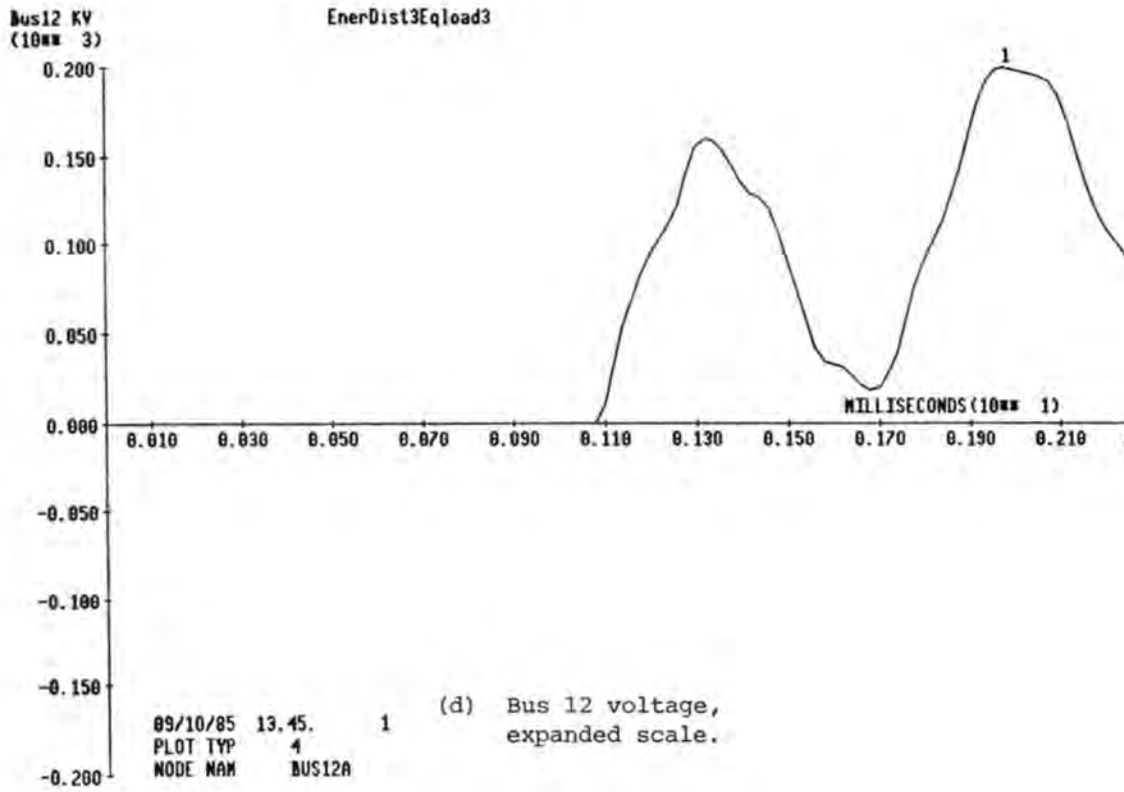
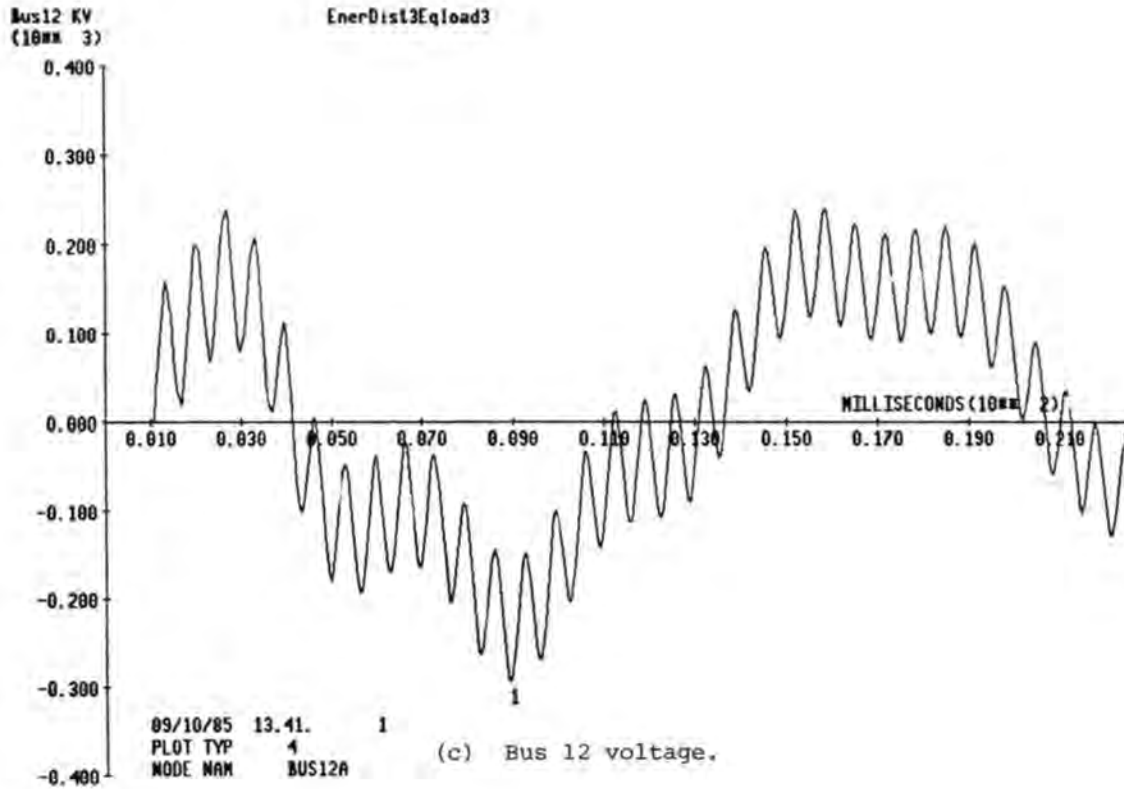

Figure 6.5: (continued).

Problem 6.1: You are given three phase transmission lines between nodes XTA, XTB and XTC and nodes RVA, RVB and RVC with the following characteristics:

(a) 150 Km transposed line, modal variables are

	Z_0 (ohms)	R' (ohms/Km)	v (Km/s)
Zero	660	.0389	259000
Positive	390	.0036	297000

(b) 150 Km untransposed line

	R' (ohms/Km)	$\omega L'$ (ohms/Km)	$\omega C'$ (mho/Km)
Mode 0	.31	1.20	2.9×10^{-6}
Mode 1	.025	.38	4.3×10^{-6}
Mode 2	.024	.31	5.1×10^{-6}

Modal matrix assumed:

$$T_i = \begin{bmatrix} .6 & -.7 & -.4 \\ .5 & 0 & .8 \\ .6 & .7 & -.4 \end{bmatrix}$$

Generate the necessary EMTP data lines to model these transmission lines.

Section 7

THE CALCULATION OF LINE PARAMETERS

The calculation of line constant parameters can be made using tables, formulas, or the EMTP itself. The EMTP has a built-in line constants calculation routine, "LINE CONSTANTS". The program uses well established formulas to calculate all inductances and capacitances. The formulas used by the EMTP take full account of skin effects and frequency dependencies due to ground resistivity (using Carson's formulas). The information needed by the line constants program is:

- Relative position of every conductor.
- Resistivity of conductors and ground.
- Size of every conductor.
- Identification of each conductor as belonging to "ground" or to a phase.

The preparation of EMTP data for the line constants program is as follows:

```
BEGIN NEW DATA CASE  
  
LINE CONSTANTS  
  
Conductor Data  
  
BLANK End of Conductor Data  
  
Frequency Data  
  
BLANK End of Frequency Data  
  
BLANK End of LINE CONSTANTS cases  
  
BLANK End of EMTP cases
```

The conductor data is organized using one data line per conductor. It is also possible to specify a bundle of conductors in a single data line. The data line for unbundled conductors is:

Col. 1-3: Phase number (0 for ground conductor). All conductors of the
(I3) same phase have the same number

Col. 4-8: Skin effect ratio for hollow conductors: (Thickness/Diameter.)
(F5.4) It has a value of .5 for solid conductors. Treat ACSR as hollow.

Col. 9-16: R' , DC resistance of conductor in either ohms/mile or ohms/Km.
(F8.5)

Col. 18: A "4" to signify that the program is to calculate the
(I1) inductance.

Col. 27-34: Outside diameter in inches or cm.
(F8.5)

Col. 35-42: Horizontal position relative to an arbitrary position, in feet
(F8.5) or m.

Col. 43-50: Height at tower, in feet or m.
(F8.5)

Col. 51-58: Mid-span height in feet or m.
(F8.5)

To specify not one conductor but a bundle, add the following:

Col. 59-66: Separation among conductors in bundle in inches or cm.
(F8.5)

Col. 79-80: Number of conductors in bundle.
(I2)

The format for the frequency data is:

Col. 1-8: Earth resistivity in ohm-m.

(F8.2) 100 is a typical value.

Col. 9-18: Frequency in Hz.

(F10.2)

Col. 28: Put a "1" to request Carson correction.

(I1)

Col. 30-35: Request output of shunt capacitance matrices.

(6I1)

Col. 37-42: Request output of series inductance matrices.

(6I1)

Col 44: 1: values of C in μF

(I1) 0: values of C in ohms.

Col. 58: 0: ground wires are continuous

(I1) 1: ground wires are segmented.

For other items, refer to the EMTP rule book.

The EMTP performs its LINE CONSTANTS calculations and presents its results in a number of ways. For transposed lines the formation normally of interest is the information concerning the sequence equivalent conductors. This information can be obtained from the sequence (modal in this case) summary table that is printed into the EMTP output file, or it can be obtained from the shunt symmetrical component impedance matrices that are printed if requested.

For untransposed lines in addition to the modal table is produced, the modal matrix T_f is also printed.

Figure 7.1 illustrates the 230 kV line of interest used throughout this workbook. Figure 7.2 illustrates the EMTP input to calculate the parameters of this line, and Figure 7.3 illustrates the EMTP output if a transposed assumption is requested, Figure 7.4 illustrates the case of the untransposed assumption input and Figure 7.5 the untransposed output.

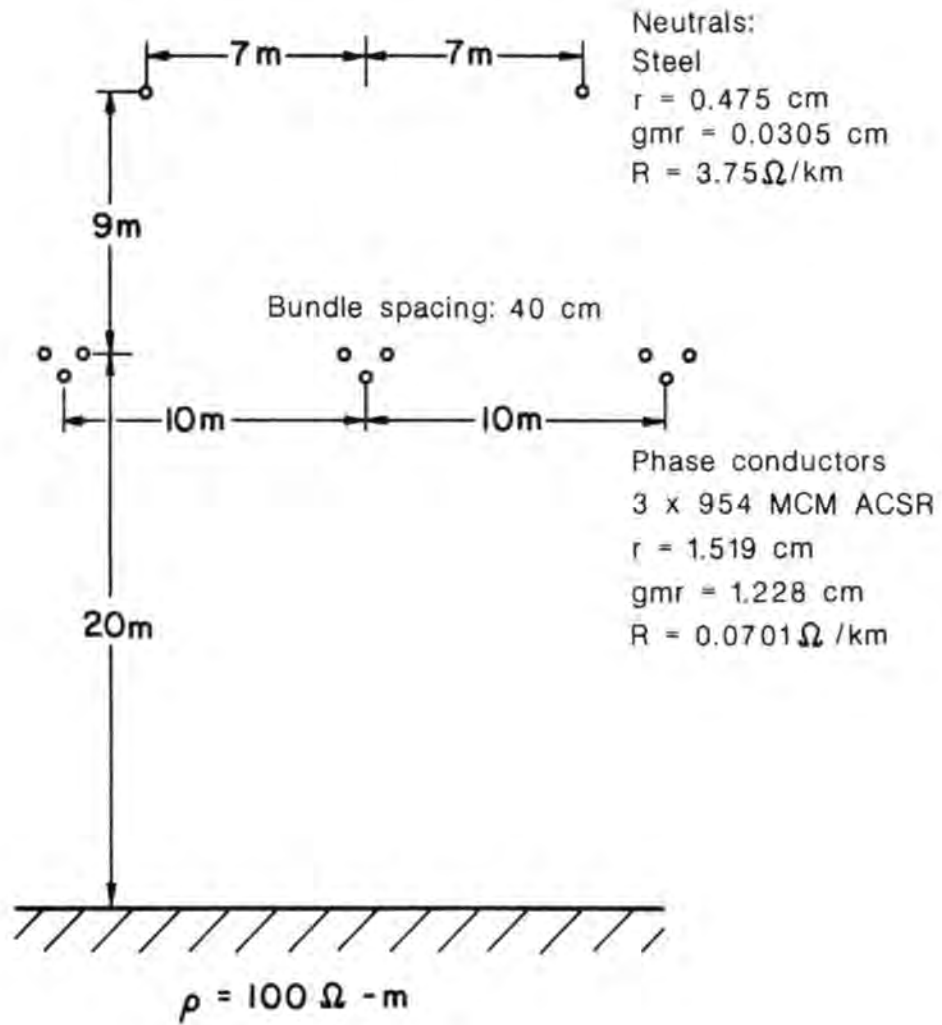

Figure 7.1: The line of interest.

```

C Template for Line Constants Data Input----- Figure 7.2 -----
BEGIN NEW DATA CASE
LINE CONSTANTS
METRIC
C      1      2      3      4      5      6      7      8
C 345678 012345678 012345678 012345678 012345678 012345678 012345678 012345678 0
C
C Conductor Data
C p s r d h v v s a n n
C h k e cm i m o m t m m cm e l a b
C a i ohms s in a ft r ft o ft i in p p mu
C s<---n<-----i 4 <---m<---i<---w<---d<---a<---h<---e<n
0 0.50 3.750 4 0.950 -7.0 29. 29.
0 0.50 3.750 4 0.950 7.0 29. 29.
1 0.50 0.0701 4 3.058 -10.0 20. 20. 40. 3
2 0.50 0.0701 4 3.058 0.0 20. 20. 40. 3
3 0.50 0.0701 4 3.058 10.0 20. 20. 40. 3
BLANK End of Conductor Cards
C Frequency Cards
C f C print> print> I d IM I I U
C ohm-mr Hz r a inv inv c i prntsu d p n
C h e r CCCCCC ZZZZZZ a s YYZZet e n t
C ---o<-----q s es es es es p <---t s sgu<c<-t r
100. 60. I 111111 111111 1
BLANK End of Frequency Cards
BLANK End of Case
BLANK End of All Cases

```

Figure 7.2: EMTP Input to Determine Parameters of Line. Transposition assumed

SEQUENCE	SURGE IMPEDANCE		ATTENUATION	VELOCITY
	MAGNITUDE (OHM)	ANGLE (DEGR.)	DB/KM	KM/S
ZERO	0.65056E+03	-0.73080E+01	0.21319E-02	0.19698E+06
POSITIVE	0.27109E+03	-0.19990E+01	0.39018E-03	0.29292E+06

SEQUENCE	WAVELENGTH	RESISTANCE	REACTANCE	SUSCEPTANCE
	KM	GHM/KM	GHM/KM	MHO/KM
ZERO	0.32829E+04	0.31676E+00	0.12147E+01	0.29660E-05
POSITIVE	0.48819E+04	0.24340E-01	0.34826E+00	0.47505E-05

Figure 7.3: Selected Output from Line Constants, Transposed Line

```

C Template for Line Constants Data Input ----- Figure 7.4 -----
BEGIN NEW DATA CASE
LINE CONSTANTS
METRIC
C      1      2      3      4      5      6      7      8
C 345678 012345678 012345678 012345678 012345678 012345678 012345678 0
C
C Conductor Data
C p      s      r      d      h      v      v      s      a      n      n
C h      k      e      cm   i      o      t      m      e      l      a      b
C a      i      ohms s      in   a      r      o      i      p      p      mu
C s<---n<-----i 4      <-----m<-----i<-----w<-----d<-----a<-----h<-----e<n
0 0.50  3.750 4      0.950  -7.0  29.  29.
0 0.50  3.750 4      0.950   7.0  29.  29.
1 0.50  0.0701 4      3.058 -10.2  20.  20.
1 0.50  0.0701 4      3.058 - 9.8  20.  20.
1 0.50  0.0701 4      3.058 -10.0 19.65 19.65
2 0.50  0.0701 4      3.058 - 0.2  20.  20.
2 0.50  0.0701 4      3.058   0.2  20.  20.
2 0.50  0.0701 4      3.058   0.0 19.65 19.65
3 0.50  0.0701 4      3.058   9.8  20.  20.
3 0.50  0.0701 4      3.058  10.2  20.  20.
3 0.50  0.0701 4      3.058  10.0 19.65 19.65
BLANK End of Conductor Cards
C Frequency Cards
C      f      print> print> I      d      IM I I      U
C      r      r      inv   inv   c      i      prnts u d p      n
C      h      e      CCCCCC ZZZZZZ a      s      YYZZet e n      t
C -----o<-----q      1 es es es es p <-----t      s sgu<-c<-t      r
      100.      60.      1 11 11 11 11 1      1111      1
BLANK End of Frequency Cards
BLANK End of Case
BLANK End of All Cases

```

Figure 7.4: EMTP Input to Determine Parameters of Line. Untransposed Line. Bundling Option was not used. Each Conductor in Bundling Specified Separately

MODE	RESISTANCE	REACTANCE	SUSCEPTANCE	SURGE IMPEDANCE (OHM)			VELOCITY	ATTENUATION
	OHM/KM	OHM/KM	S/KM	REAL	IMAG	LOSSLESS	KM/SEC	NEPER/KM
1	0.31399E+00	0.12049E+01	0.29881E-05	0.64029E+03	-0.82055E+02	0.63501E+03	0.19704E+06	0.24519E-03
2	0.24689E-01	0.38277E+00	0.43407E-05	0.29711E+03	-0.95719E+01	0.29695E+03	0.29232E+06	0.41549E-04
3	0.23914E-01	0.31245E+00	0.51700E-05	0.24602E+03	-0.94008E+01	0.24584E+03	0.29640E+06	0.48602E-04

7-7

EIGENVECTOR MATRIX T1 FOR CURRENT TRANSFORMATION I(PHASE)=T1*I(MODE)

REAL COMPONENTS, ROW BY ROW
0.59521E+00-0.70711E+00-0.41241E+00
0.53986E+00-0.15923E-13 0.81230E+00
0.59521E+00 0.70711E+00-0.41241E+00

Figure 7.5: Selected Output from Line Constants, Untransposed Line

Problem 7.1: Prepare EMTP data to calculate the line parameters for a 3 phase line as illustrated below

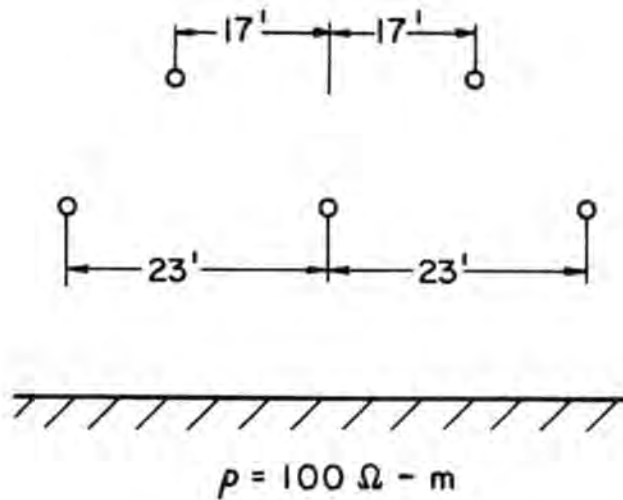

Ground:

Ht @ tower: 100'

Ht @ midspan: 75'

Phase:

Ht @ tower: 88'

Ht @ midspan: 50'

Ground conductors: solid, $R' = .002$ ohms/mi

diameter = .525"

Phase conductors: solid: $R' = .001$ ohms/mi

diameter = .994"

Calculate parameters at 60 Hz and at 1 KHz. Assume line is transposed.

Section 8

SOURCE REPRESENTATION

It is impractical to represent in detail the entire interconnected power system for every study. At some point it is necessary to represent the system as an approximation. For simplicity assume that the breaker at "2" in line "1-2" is open. The line from 1 to 12 may or may not be in service. The study concerns faults and transients on the line. Consider three types of models:

- Represent the system as an ideal voltage source at bus 1.
- Represent the generator as bus 1 as a voltage behind transient reactance, and represent the network as seen from bus 1 as a Thevenin equivalent.
- Represent the generator as a voltage behind transient reactance, represent the line from 7 to 1 in detail, and represent the rest of the system as a Thevenin equivalent.

This section describes how to get Thevenin equivalents, and some of their limitations. Thevenin equivalents can be obtained from short circuit studies, such as those shown in section I. To get a Thevenin equivalent impedance (valid at 60 Hz) it is necessary to have total fault current results from a SLG and a 3 PH fault at the desired point, with ONLY the portion of the system to be equivalenced in service. This last point is very important. For example, to obtain the Thevenin equivalent of the rest of the system as seen from bus 1 it is necessary to remove line 1-2 (which we will be studying in detail and therefore do not want to equivalence) and generator 3 (which we want to keep in our model). The results for short circuit studies without these two components are illustrated in Figure 2.6(b) in section 2:

$$I_f (3PH) = 7.85 \angle -86.8 \text{ pu}$$

$$I_f (SLG) = 4.78 \angle -80.0 \text{ pu}$$

To obtain the sequence Thevenin impedances (in per unit) from these values remember that:

$$I_f (3PH) = \frac{1}{Z^+}$$

$$I_f (SLG) = \frac{3}{Z^0 + 2Z^+}$$

Obtain Z^+ from here:

$$Z^+ = \frac{1}{I_f (3PH)}$$

$$Z^0 = \frac{3}{I_f (SLG)} - \frac{2}{I_f (3PH)}$$

For the specific example, these values are

$$Z^+ = .1274 \angle 86.8 = .0071 + j .1272 \text{ pu}$$

$$Z^0 = .3758 \angle 75.4 = .0947 + j .3637 \text{ pu}$$

To convert these values to actual ohms, it is necessary to know the impedance base

$$Z_b = \frac{KV_b^2}{MVA_b} = \frac{230^2}{100} = 529$$

Therefore:

$$Z^+ = 3.75 + j 67.3 \text{ ohms}$$

$$Z^0 = 50.1 + j 192.4 \text{ ohms}$$

These impedances are valid only at 60 Hz. To convert these impedances to actual RLC values it is necessary to make an extremely important assumption about the FORM of the model to use. If there is no capacitance at the bus and there are no significant transmission lines, then it may be assumed that an RL model is adequate. OTHERWISE THIS CANNOT BE DONE.

If the network as seen from bus 1 as an RL network is represented as a pure RL network, then the corresponding values of R and L are:

$$R^+ = 3.75 \text{ ohms} \quad L^+ = 17.8 \text{ mH}$$

$$R^0 = 50.1 \text{ ohms} \quad L^0 = 510.34 \text{ mH}$$

As will be illustrated shortly, THESE VALUES ARE INCORRECT. The line from 1 to 7 is too important and cannot be neglected. A better model is obtained if line 1-7 is represented in detail, and the equivalent as seen from bus 7 is calculated. The data for this calculation is given in Figure 2.6(d) in section 2. A similar but separate calculation for the generator at bus 3 yields the following Thevenin equivalent for this generator and transformer combination:

$$Z^0 = j .06 \text{ pu}$$

$$Z^1 = j .11 \text{ pu}$$

From here:

$$R^0 = 0 \quad L^0 = 84.2$$

$$R^1 = 0 \quad L^1 = 154.4$$

Problem 8.1: Using the data from figure 2.6(c) in section 2, obtain the values for the Thevenin equivalent as seen from bus 7:

$$R^0 = \quad L^0 =$$

$$R^1 = \quad L^1 =$$

The Thevenin values obtain are sequence values. The EMTP works in actual phase values. These sequence values are the result of assuming mutual coupling between

the phases. Figure 8.1 illustrates the actual form of the assumed source equivalent. To obtain the values of the source self and mutual impedances we need to use the following equations:

$$Z_s = \frac{1}{3} (Z_o + 2 Z_1)$$

$$Z_m = \frac{1}{3} (Z_o - Z_1)$$

Thus, in the phase domain the source network is representable as 3 coupled RL branches described by the following matrix:

$$\begin{bmatrix} Z_s & Z_m & Z_m \\ Z_m & Z_s & Z_m \\ Z_m & Z_m & Z_s \end{bmatrix}$$

For the specific example at hand, the corresponding equivalent phase impedances as seen from bus 1 are:

$$Z_s = 19.2 + j 109$$

$$Z_m = 15.4 + j 41.7$$

Problem 8.2: Obtain values of R_s , L_s , R_m and L_m for the Thevenin equivalent as seen from bus 7.

$$R_s = \qquad L_s =$$

$$R_m = \qquad L_m =$$

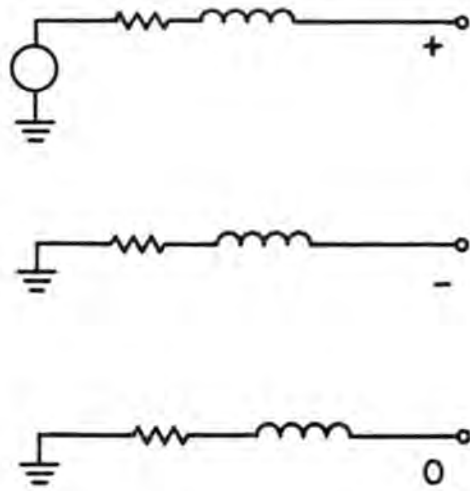

(a) In the sequence domain.

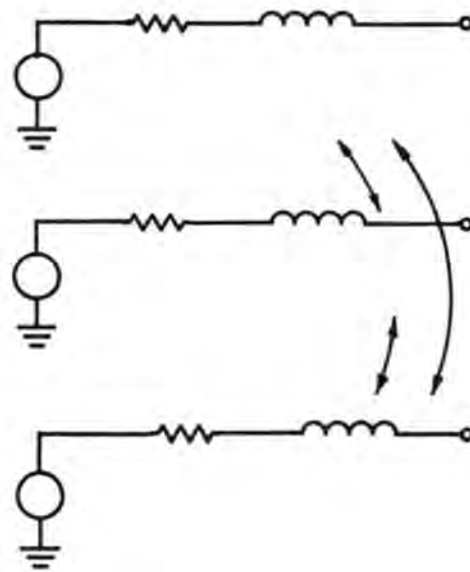

(b) In the phase domain.

Figure 8.1: The form of the Thevenin equivalent.

The EMTP accepts data for mutually coupled RL branches as branches of type 51, 52, 53. It accepts either detailed coupling matrix information or sequence information. If sequence information is specified, the EMTP does the calculation of the phase matrices internally.

As mentioned previously, Thevenin equivalents obtained in this manner are only truly valid for fundamental frequency studies. They are not all that suitable for transient studies. However, the errors introduced by the equivalent can be reduced if the following guidelines are followed:

- Represent all capacitances separately. Even very small capacitances can be quite important.
- Any transmission line at the point of the equivalent should be represented either in detail as a distributed line or at least as a shunt resistances with a numeric value equal to their characteristic impedance.

Exact EMTP data preparation instructions for the representation of mutually coupled RL branches follows:

Col. 1-2: Phase. First coupled line: 51;
Second coupled line: 52; etc.

Col. 3-14: Bus names.

Col. 27-32: R11 (first line); R21 (second line); etc.

Col. 33-44: L11 (first line); L21 (second line); etc.

Col. 45-50: Not used (first line); R22 (second line); etc,
and so on. See data sheets for the following
problem for details.

Problem 8.3: Represent the Thevenin impedance as seen from bus 7 as:

(a) Using the full phase R-L matrix model.

(b) The sequence parameters.

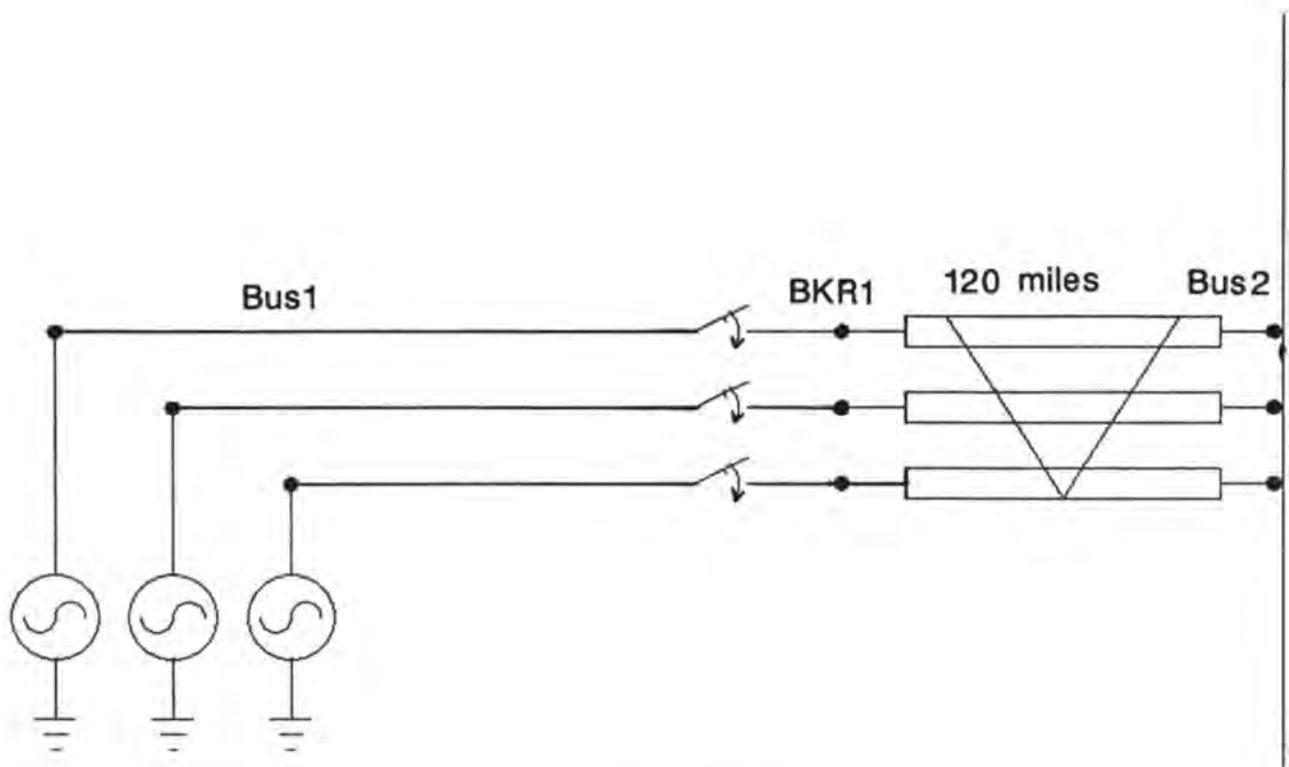

(a) Circuit Diagram

Figure 8.2: Energization of transposed line 1-2 from an ideal voltage source. This model is inadequate.

```

BEGIN NEW DATA CASE
C -----Figure 8.2(b)-----
C Energization of a 230 KV 120 Mile line from an ideal source .
C using actual units, THREE PHASE DISTRIBUTED LINE model .
C ----dt<---tmax<----->
C 20.E-6 25.E-3
C -Iprnt<--Iplot<-Idoubl<-KssOut<-MaxOut <---Icat
C 15 1 0 0 0 2
C
C .....Circuit data.....
C Bus-->Bus-->Bus-->Bus--><---R<---L<---C 0
C Bus-->Bus--><---<---R<---L<---R<---L<---R<---L
C Bus-->Bus-->Bus-->Bus--><---R'<---L'<---C'<---len 0 0 0<---Blank-->0
-1BKR1A BUS2A 0.3167 3.222.00787 193.1 0 0 0 0
-2BKR1B BUS2B 0.0243 .9238 .0126 193.1 0 0 0 0
-3BKR1C BUS2C 0
BLANK End of circuit data.....!
C
C .....Switch data.....
C Bus-->Bus--><---Tclose<---Topen<---Ie 0
BUS1A BKR1A 1.E-3 9999. 0 0
BUS1B BKR1B 1.E-3 9999. 0 0
BUS1C BKR1C 1.E-3 9999. 0 0
BLANK End of switch data.....!
C
C .....Source data.....
C Bus--><I<Amplitude<Frequency<---T0!Phi0<---0=Phi0 <---Tstart<---Tstop
14BUS1A 187.79 60. 0. 0. -1. 9999.
14BUS1B 187.79 60. -120. 0. -1. 9999.
14BUS1C 187.79 60. 120. 0. -1. 9999.
C peak Line to ground voltage for a 230 KV RMS line to line source is 187.79KV !
BLANK End of source data.....!
C
C .....Output Request Data.....
C Bus-->Bus-->Bus-->Bus-->Bus-->Bus-->Bus-->Bus-->Bus-->Bus-->Bus-->
BUS1A BUS2A BUS2B
BLANK End of output requests.....!
C
C Plot request Data.....
2Energize 120mi 3phase Dist Ideal source at 1
C _____Graph type: 4(volts) 8(branch volts) 9(currents) .
C | _____Units: 1(deg) 2(cyc) 3(sec) 4(msec) 5(microsec) .
C || _____Units per inch .
C || | _____Plot starting time .
C || | | _____Plot stopping time .
C || | | | _____Value at bottom of vertical scale .
C || | | | | _____Value at top of vertical scale .
C || | | | | | .
C VV<-|<--|<--|<--|<--|Bus-->Bus-->Bus-->Bus-->Heading----->Vert axis----->
1442.5 0.0 25.-500.500.BUS2A BUS2B EnerDist3Ideal Bus2 KV
BLANK End of Plot Request.....!
BLANK End of All Cases

```

(b) Input data.

Figure 8.2: (continued).

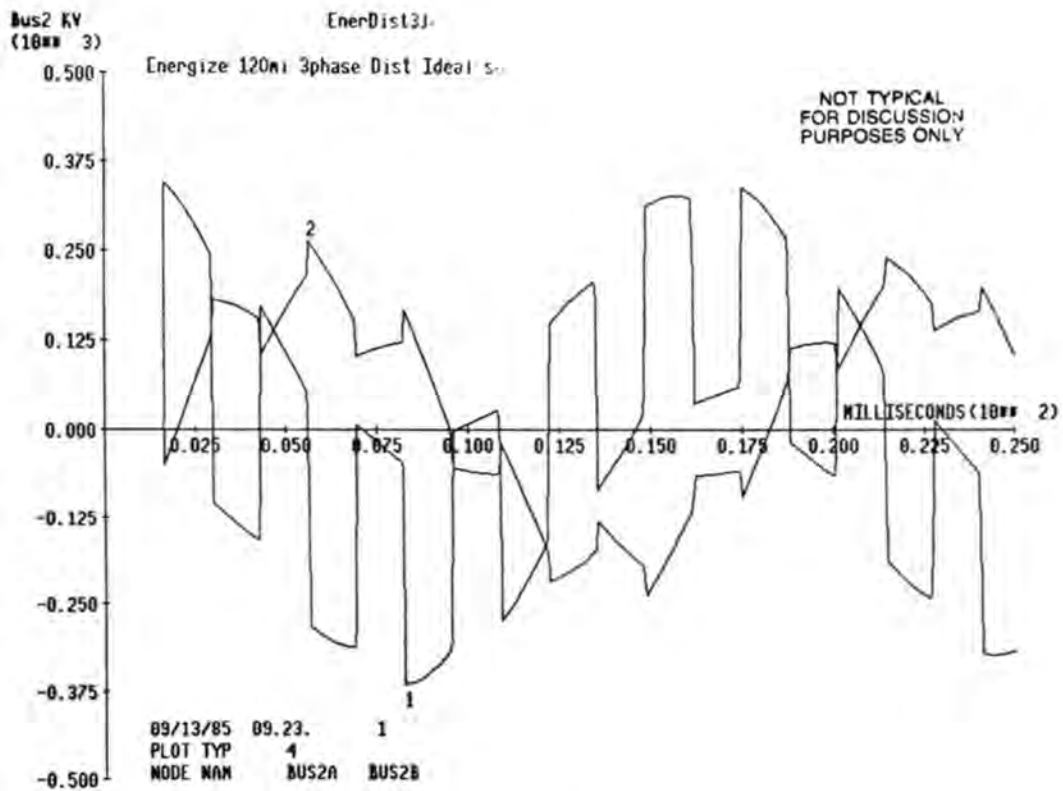

(c) Bus 2 Voltages, phases a and b.

Figure 8.2: (continued).

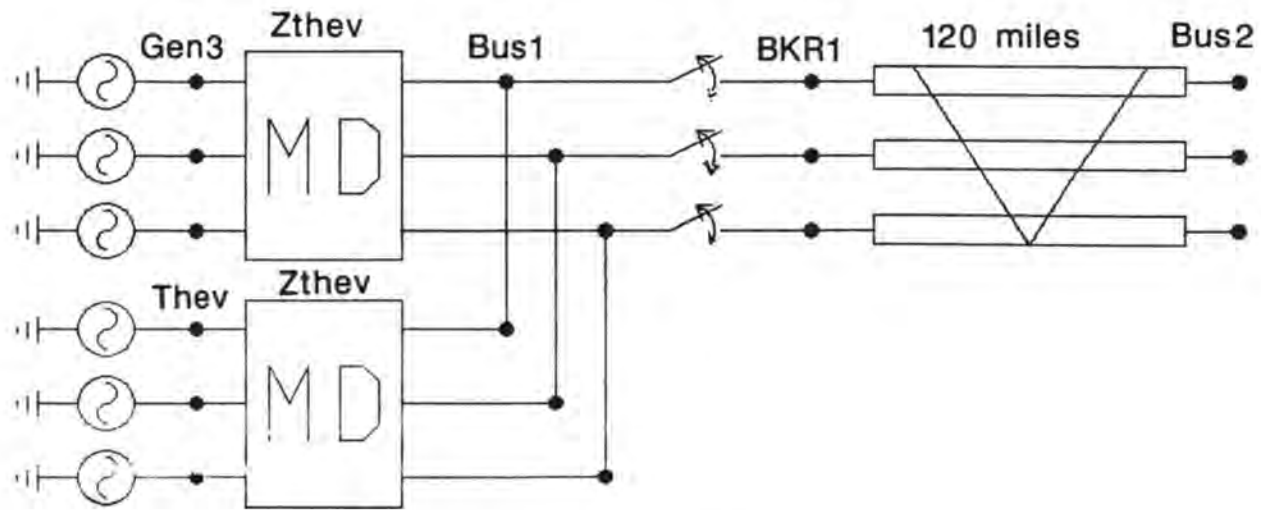

(a) Circuit Diagram

Figure 8.3: Energization of transposed line 1-2 using a Thevenin equivalent at bus 1. This model is marginally adequate.

```

BEGIN NEW DATA CASE
C .....Figure 8.3(b).....
C Energization of a 120 MILE line from a Thevenin voltage source at Bus 1
C ----dt<----tmax.....
  20.E-6 25.E-3
C -Iprnt<--Iplot<-Idoubl<-KssOut<-MaxOut          <---Icat
   15      1      0      0      0                  0
C
C .....Circuit data.....
C Bus-->Bus--><-----><---R<-----L<---R<-----L
51THEVA BUS1A      50.1      510.34      0
52THEVB BUS1B      3.75      178.50      0
53THEVC BUS1C      0          84.2       0
51GEN3A BUS1A      0          154.4     0
52GEN3B BUS1B      0          154.4     0
53GEN3C BUS1C      0          154.4     0
C Bus-->Bus-->Bus-->Bus--><---R'<---L'<---C'<---len 0 0 0<---Blank----->0
-1BKR1A BUS2A      0.3167 3.222,00787 193.1 0 0 0
-2BKR1B BUS2B      0.0243 ,9238 ,0126 193.1 0 0 0
-3BKR1C BUS2C      0          0          0          0
BLANK End of circuit data.....
C
C .....Switch data.....
C Bus-->Bus--><---Tclose<---Topen<-----Ie
BUS1A BKR1A      1.E-3 9999.      0
BUS1B BKR1B      1.E-3 9999.      0
BUS1C BKR1C      1.E-3 9999.      0
BLANK End of switch data.....
C
C .....Source data.....
C Bus--><I<Amplitude<Frequency<---T0:Phi0<---0=Phi0<-Ignore-><---tstart<---Tstop
14THEVA      187.79      60.      0.      0.      -1.      0.
14THEVB      187.79      60.     -120.     0.      -1.      0.
14THEVC      187.79      60.     120.     0.      -1.      0.
14GEN3A      187.79      60.      0.      0.      -1.      0.
14GEN3B      187.79      60.     -120.     0.      -1.      0.
14GEN3C      187.79      60.     120.     0.      -1.      0.
BLANK End of source data.....
C
C .....Output Request Data.....
C Bus-->Bus-->Bus-->Bus-->Bus-->Bus-->Bus-->Bus-->Bus-->Bus-->Bus-->
BUS1A BUS2A BUS2B
BLANK End of output requests.....
C
C Plot request Data.....
2Energize 120mi 3phase Dist thevenin at bus 1
C -----Graph type: 4(volts) 8(branch volts) 9(currents)
C :-----Units: 1(deg) 2(cyc) 3(sec) 4(msec) 5(microsec)
C ::-----Units per inch
C :: :-----Plot starting time
C :: :-----Plot stopping time
C :: :-----Value at bottom of vertical scale
C :: :-----Value at top of vertical scale
C VV<--<--<--<--<--<Bus-->Bus-->Bus-->Bus-->Heading----->Vert axis----->
  1442.5 0.0 25.-500.500.BUS2A BUS2B      EnerDist3Thev1 Bus2 KV
BLANK End of Plot Request.....
BEGIN NEW DATA CASE
BLANK End of All Cases

```

(b) Input data.

Figure 8.3: (continued).

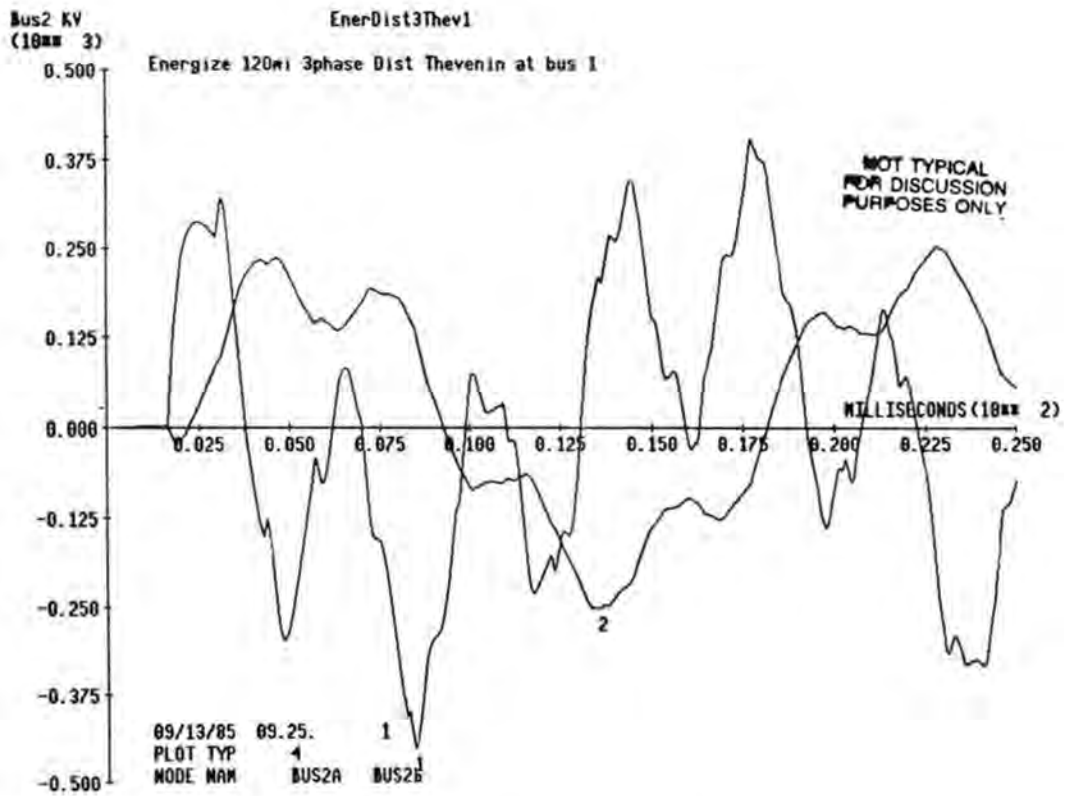

(c) Bus 2 voltages.

Figure 8.3: (continued).

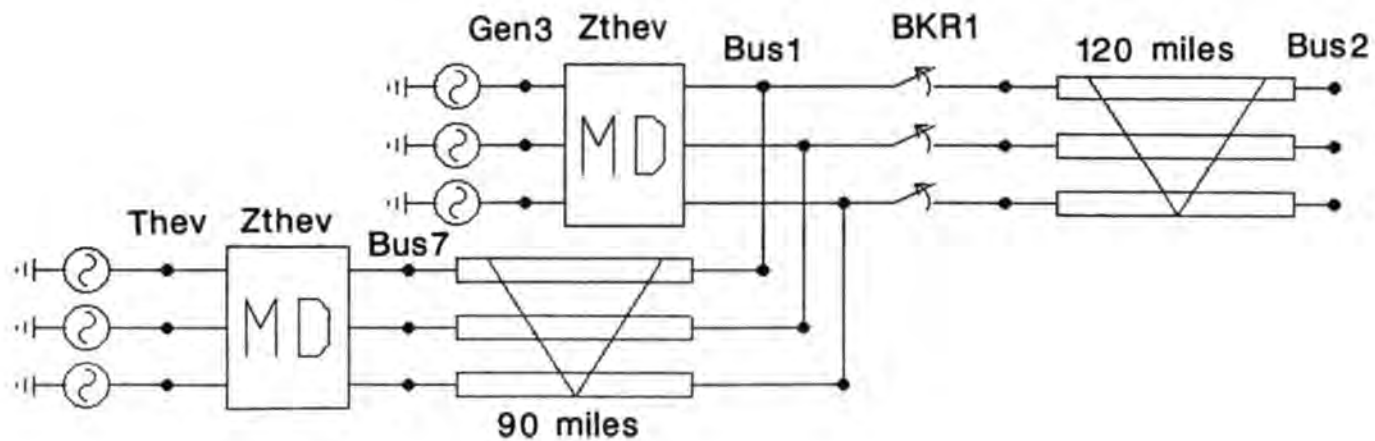

(a) Circuit diagram.

Figure 8.4: Energization of transposed line 1-2 with line 7-1 represented in detail and Thevenin equivalents at buses 1 and 7. This model is adequate.

```

BEGIN NEW DATA CASE
C .....Figure 8.4(b).....
C Energization of a 230 KV 120 Mile line from a Thevenin source at bus 7
C ----dt<---tmax.....
C 20.E-6  25.E-3
C -Iprnt<---Iplot<---Idoubl<---KssOut<---MaxOut          <---Icat
C      15      1      0      0      0              0
C
C .....Circuit data.....
C Bus-->Bus--><-----<-----R<-----L<-----R<-----L<-----R<-----L
51THEVA BUS7A      .13      23.71          0
52THEVB BUS7B      .06      39.99          0
53THEVC BUS7C          0          84.2          0
51GEN3A BUS1A          0          154.4         0
52GEN3B BUS1B          0          154.4         0
53GEN3C BUS1C          0          154.4         0
C Bus-->Bus-->Bus-->Bus--><---R'<---L'<---C'<---len 0 0 0<---Blank----->0
-1BUS7A BUS1A      0.3167 3.222.00787 144.8 0 0 0
-2BUS7B BUS1B      0.0243 .9238 .0126 144.8 0 0 0
-3BUS7C BUS1C          0          0          0          0
-1BKR1A BUS2A      0.3167 3.222.00787 193.1 0 0 0
-2BKR1B BUS2B      0.0243 .9238 .0126 193.1 0 0 0
-3BKR1C BUS2C          0          0          0          0
BLANK End of circuit data.....!
C
C .....Switch data.....
C Bus-->Bus--><---Tclose<---Topen<---Ie
BUS1A BKR1A      1.E-3  9999.    0
BUS1B BKR1B      1.E-3  9999.    0
BUS1C BKR1C      1.E-3  9999.    0
BLANK End of switch data.....!
C
C .....Source data.....
C Bus--><I<Amplitude<Frequency<---T0:Phi0<---O=Phi0<Ignore-><---Tstart<---Tstop
14THEVA      187.79  60.    0.    0.    -1.    0.
14THEVB      187.79  60.  -120.  0.    -1.    0.
14THEVC      187.79  60.   120.  0.    -1.    0.
14GEN3A      187.79  60.    0.    0.    -1.    0.
14GEN3B      187.79  60.  -120.  0.    -1.    0.
14GEN3C      187.79  60.   120.  0.    -1.    0.
C peak Line to ground voltage for a 230 KV RMS line to line source is 187.79KV
BLANK End of source data.....!
C
C .....Output Request Data.....
C Bus-->Bus-->Bus-->Bus-->Bus-->Bus-->Bus-->Bus-->Bus-->Bus-->Bus-->
BUS1A BUS2A BUS2B
BLANK End of output requests.....!
C
C Plot request Data.....
2Energize 120mi 3phase Dist Thevenin at bus 7
C _____Graph type: 4(volts) 8(branch volts) 9(currents)
C | _____Units: 1(deg) 2(cyc) 3(sec) 4(msec) 5(microsec)
C || _____Units per inch
C || | | | | _____Plot starting time
C || | | | | _____Plot stopping time
C || | | | | | | _____Value at bottom of vertical scale
C || | | | | | | _____Value at top of vertical scale
C || | | | | | | | |
C VV<--<--<--<--<--<--<--<--<--<--<--<--<--<--<--<--<--<--<--<-->Vert axis----->

```

(b) Input data.

Figure 8.4: (continued).

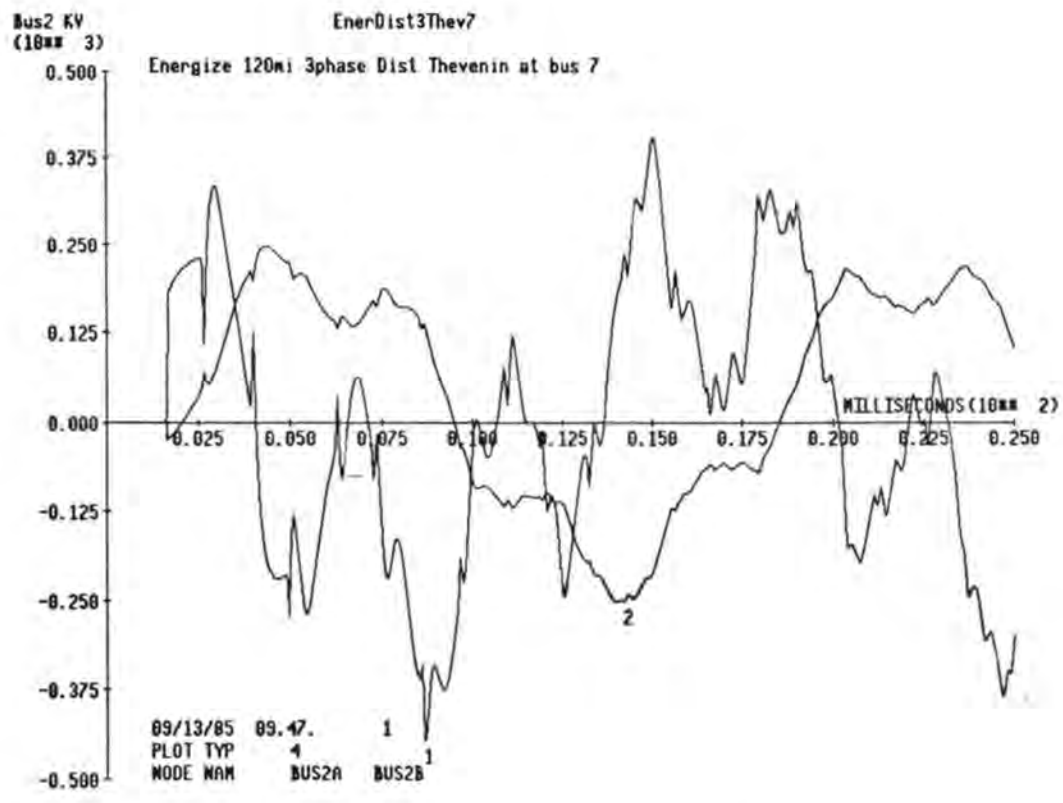

(c) Bus 2 voltages, phases a and b.

Figure 8.4: (continued).

As examples of the three types of source representation, line 1-2 open at the receiving end is energized using with each of the three source models. Figure 8.2 illustrates the ideal source model, Figure 8.3 uses a Thevenin equivalent at bus 1, and Figure 8.4 uses a Thevenin equivalent at bus 7. Notice that line 1-2 is much longer than line 1-12, and all travel times are much more apparent. The importance of a reasonable source representation should be evident from these examples. Figure 8.4 gives adequate results, but Figures 8.2 and 8.3 do not.

Section 9

TRANSIENTS CAUSED BY FAULTS

Analytic calculation of sustained overvoltages

The occurrence of a SLG fault almost invariably results in both a transient overvoltage in the unfaulted phases and a sustained power frequency overvoltage in the unfaulted phases. To understand the nature and magnitude of the sustained fundamental frequency overvoltage, consider a single line to ground fault at node i , phase a of the trivial circuit in Figure 9.1.

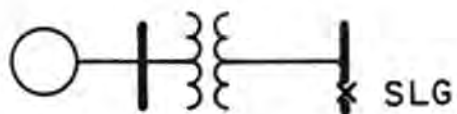

Figure 9.1: Illustration of fault induced overvoltages.

Assume that the sequence Z-bus elements at the point of the fault are known. The faulting sequence currents can be readily determined to be:

$$I_i^0 = I_i^1 = I_i^2 = \frac{-V_f}{z_{ii}^0 + z_{ii}^1 + z_{ii}^2 + 3Z_f}$$

From here, the sequence voltage V changes caused by the fault

$$\Delta V_j^0 = z_{ji}^0 I_i^1 \quad \Delta V_j^1 = z_{ji}^1 I_i^1 \quad \Delta V_j^2 = z_{ji}^2 I_i^1$$

The phase voltage changes at the faulted node can then be found from:

$$\Delta V_i^b = (z_{ii}^0 + a^2 z_{ii}^1 + a z_{ii}^2) I_i^1$$

$$\Delta V_i^c = (z_{ii}^0 + a z_{ii}^1 + a^2 z_{ii}^2) I_i^1$$

The actual voltages can then be determined by superimposing the pre-fault voltages $V_i^b = a^2 V_f$ and $V_i^c = a V_f$ to the voltage changes:

$$V_i^b = \left(a^2 - \frac{\overbrace{z_{ii}^0 + a^2 z_{ii}^1 + a z_{ii}^2}^{K_i^b}}{z_{ii}^0 + z_{ii}^1 + z_{ii}^2 + 3Z_f} \right) V_f$$

$$V_i^c = \left(a - \frac{z_{ii}^0 + a z_{ii}^1 + a^2 z_{ii}^2}{\underbrace{z_{ii}^0 + z_{ii}^1 + a^2 z_{ii}^2 + 3Z_f}_{K_i^c}} \right) V_f$$

The quantities in parentheses can have a magnitude greater than unity, which means an overvoltage condition. In particular, consider the idealized situations in Figure 9.2 (the one-line diagrams are merely to illustrate some simple configurations where the particular conditions could be approximately met): The presence of resistance in the system tends to decrease $|K_b|$ and to increase $|K_c|$. A fault resistance can result in larger overvoltages.



Equal sequence impedances results in no overvoltages.



A low zero sequence impedance results in undervoltages.



A high zero sequence impedance results in 73% overvoltage.

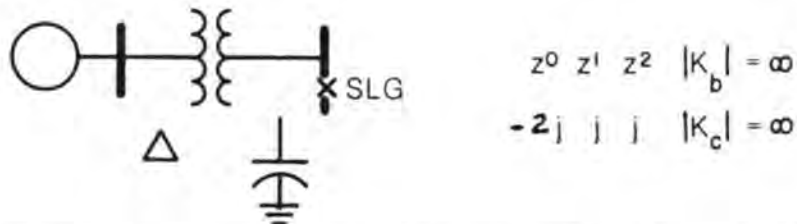

A capacitive zero sequence results in even higher overvoltages.

Figure 9.2: The effect of grounding on sustained fault overvoltages.

Problem 9.1: Using the short circuit values given in Section 2, Figure 1.6(c) and the formulas above compute the sustained overvoltage magnitudes in phases b and c for a SLG fault at bus 1.

The presence of transients further worsens these overvoltages caused by faults. Also, reflections on open ended lines can further aggravate these overvoltages.

EMTP Studies

The EMTP can be used to calculate sustained overvoltages due to faults by using it in its steady state mode. To use the EMTP in a steady state mode you must:

- Specify a negative T_{\max} in the first miscellaneous data line.
- Specify a nonzero KSSOUT in the second miscellaneous data line.

Figure 9.3 illustrates the sample input and output to evaluate the overvoltages caused by a SLG fault at bus 1 with the breaker at 2 open. The overvoltage is:

$$\frac{238.97}{187.79} = 1.27 \text{ pu on phase b}$$

$$\frac{258.44}{187.79} = 1.37 \text{ pu on phase c}$$

Figure 9.4 illustrates the transients associated with the occurrence of a SLG on the line side of the breaker at bus 1. Note that, in addition to the sustained component, there are transient components of this overvoltage. In this example the overvoltage is of the order of $(314.85/187.79 = 1.67 \text{ pu on phase c at } 9.2 \text{ ms})$.

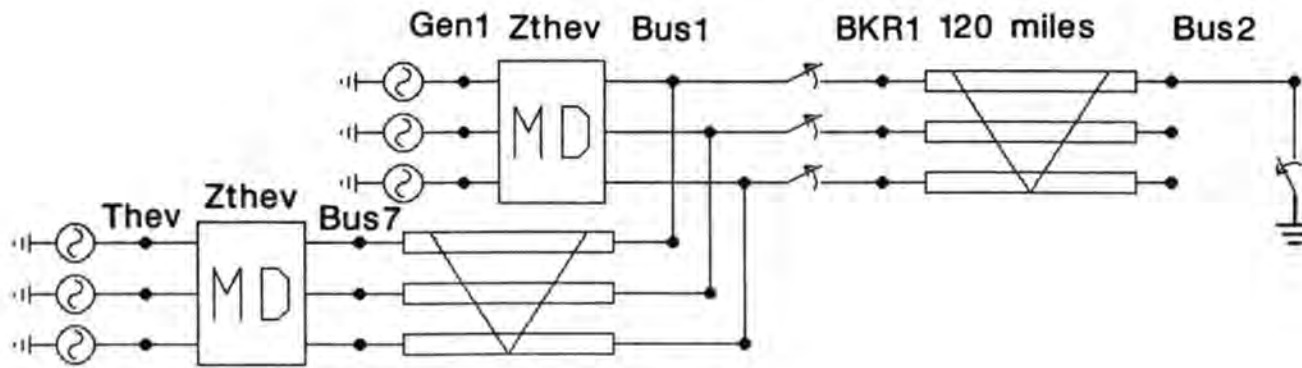

(a) Circuit diagram.

Figure 9.3: Calculation of Steady state fault overvoltages. Notice that $t_{\max} < 0$ and $KSSOUT > 0$.

BUS K	BUS M	RECTANGULAR	NODE VOLTAGE POLAR
BKR1B		-0.9688395E+02 -0.1691419E+03	0.1949243E+03 -119.8039
	BUS2B	-0.1768693E+03 -0.1607007E+03	0.2389716E+03 -137.7422
BKR1C		-0.9653099E+02 0.1703164E+03	0.1957700E+03 119.5435
	BUS2C	-0.1757356E+03 0.1895010E+03	0.2584447E+03 132.8416

(c) Sample phasor output.

Figure 9.3: (continued).

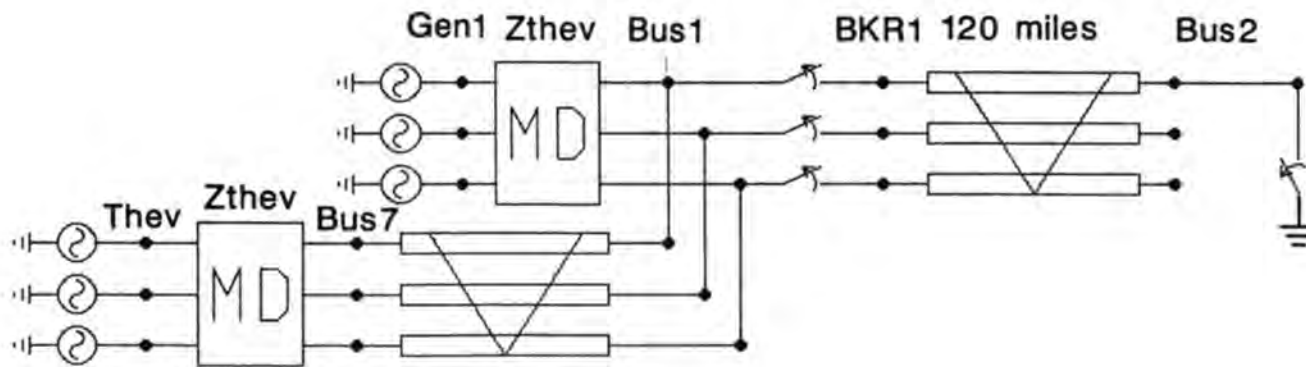

(a) Circuit diagram.

Figure 9.4: Calculation of transient fault overvoltages for a SLG fault at bus 2, phase a.

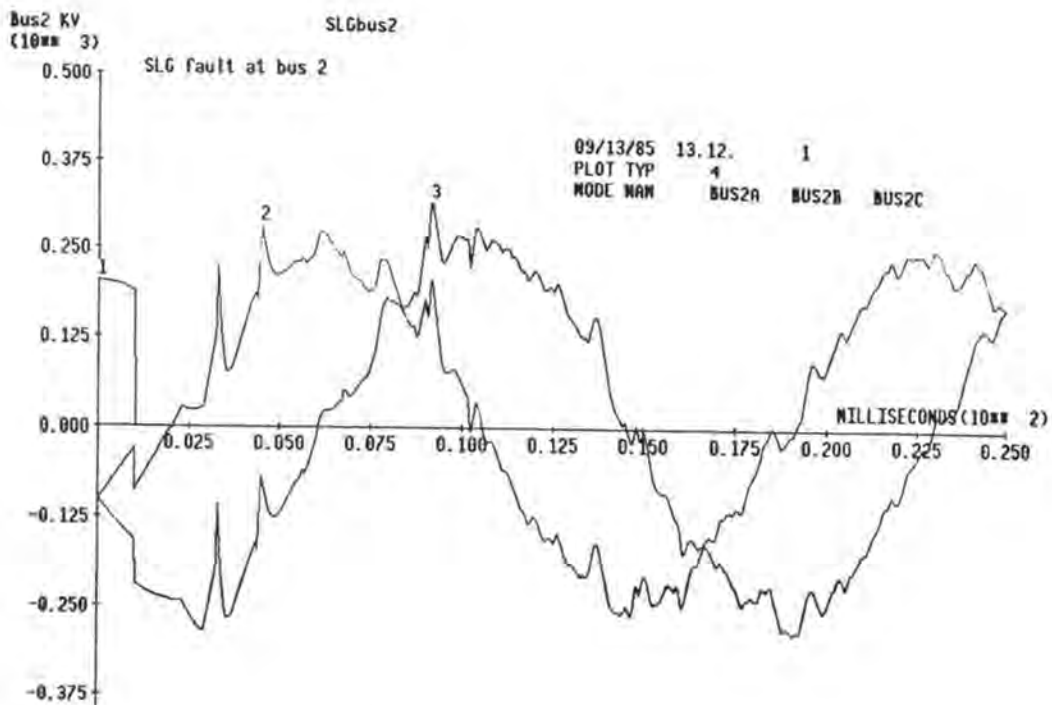

(c) Bus 2 voltages, phases a and b.

MAXIMA AND MINIMA WHICH OCCURRED DURING THE SIMULATION FOLLOW. THE ORDER AND COLUMN POSITIONING ARE THE SAME AS FOR THE REGULAR PRINTED OUTPUT VS. TIME.

VARIABLE	BUS2A	BUS2B	BUS2C
VARIABLE MAXIMA :	0.214038E+03	0.202189E+03	0.281141E+03
TIMES OF MAXIMA :	0.165800E-01	0.000000E+00	0.452000E-02
VARIABLE MINIMA :	-0.246140E+03	0.000000E+00	-0.259405E+03
TIMES OF MINIMA :	0.856000E-02	0.102000E-02	0.146600E-01

(d) Printout of maximum values.

Figure 9.4: (continued).

Section 10

TRANSIENT RECOVERY VOLTAGES (TRV)

Background

Transient recovery voltages refer to the calculation of the voltages that develop across a breaker contact when the contacts of a breaker part. Breakers can only sustain a maximum rate of rise of this voltage if their opening is to be successful. Many ANSI standards specify how to select breakers with adequate TRV capabilities (for example, ANSI C37.0731 a-1975). The EMTF permits more precise calculation of these voltages.

The most severe TRVs from an amplitude view point generally occur following the interruption of the first phase to clear an ungrounded three-phase fault. A shift in the system neutral results in high amplitude recovery voltages. This type of fault results in a TRV 1.5 times line-ground voltage.

The location of the fault is important because of impedances that may or may not be introduced. Maximum fault current is associated with a breaker terminal fault, which implies zero initial voltage on one side of the breaker. The other side sees a transient voltage determined by the connected system. The current may be reduced by incorporating additional impedance between the breaker and the fault, resulting in revisions in the shape of the recovery voltage. The short line fault is one example of this condition where current is reduced slightly and the circuit becomes markedly more difficult to interrupt. The bus transient recovery voltage is generally used as the determining factor in breaker application. It is assumed that if a breaker can meet its required bus fault TRV, it can interrupt any related requirement at reduced current, including the short line fault.

Considering the bus side only, the transient is determined by system inductances, capacitances and resistances, and whether parameters are considered lumped or distributed. These circuit elements are required to specify the TRV, yet each combination produces a unique result. The problem then becomes the development of methods that will enable the design or application engineer to obtain a reliable

estimate of TRV conditions without knowing the exact circuit parameters. Considering the bus transient, the system voltage and fault current present convenient starting points. Usually a good estimate can be made of the number of transmission lines supplying remote feed to the fault. Equivalent bus capacitance is a variable that reduces the severity of the TRV, but is a less-known factor. Series damping resistance also reduces the TRV by an unknown amount. In attempting to develop useful equivalent circuits, a major problem is to reconcile the steady-state circuit with the corresponding transient circuit. For example, representing the change from distributed inductance (steady state) to surge impedance (transient) requires careful handling. One approach is to determine the initial portion of the TRV analytically and to add the following portions based on the physical layout of the network. An analytic computation of TRV's is practical only for the very first moments after recovery begins. After a few wave reflections, it becomes impractical. Consider the very simple circuit in Figure 10.1(a) the recovery voltage (in per unit) for this circuit up until time $t = 2\tau$ is given by:

$$V_r = 1 - e^{-(Z/L)t}$$

Between $2\tau \leq t \leq 4\tau$ the recovery voltage is given by:

$$V_r = 2\frac{Z}{L}(t-2\tau) e^{-Z/L(t-2\tau)} \left[1 - \frac{Z}{L}(t-2\tau)\right]$$

The necessary data to simulate this circuit using the EMTP is given in Figure 10.1(b) and the results in Figure 10.1(c).

Problem 10.1: Verify that the EMTP results from Figure 10.1(c) agree with the formula above.

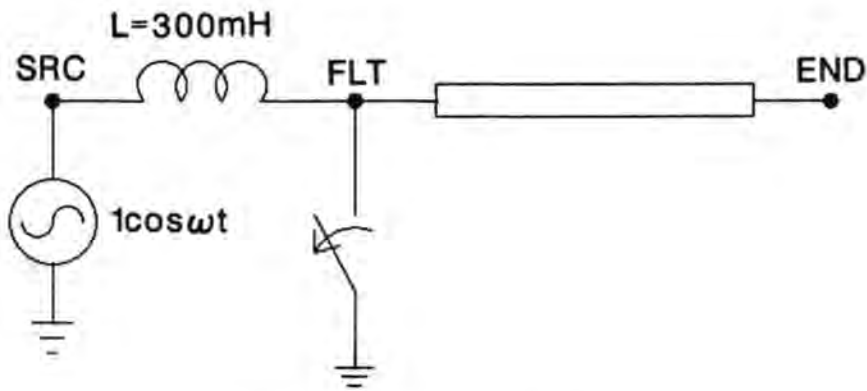

CIRCUIT DIAGRAM

(a) Circuit diagram.

Figure 10.1: A trivial TRV example.

```

BEGIN NEW DATA CASE
C -----Figure 10.1(b)-----
C Transient recovery voltage in a trivial circuit
C ----dt<---tmax<----->
  10.E-6  17.E-3
C -Iprnt<---Iplot<-Idoubl<-KssOut<-MaxOut          <---Icat
   15      1      0      0      0                    2
C
C .....Circuit data.....
C Bus-->Bus-->Bus-->Bus--><---R<---L<---C          0
  SRC  FLT          300.          0
C Bus-->Bus-->Bus-->Bus--><---R'<---Zc<---Tau<---Ien 2 0 0<---Blank----->0
  -1FLT  END          300.  .001 100.8 2 0 0
BLANK End of circuit data.....!
C
C .....Switch data.....
C Bus-->Bus--><---Tclose<---Topen<---Ie          0
  FLT          -1.E-3  1.E-3          0
BLANK End of switch data.....!
C
C .....Source data.....
C Bus--><I<Amplitude<Frequency<---T0;Phi0<---O=Phi0          <---Tstart<---Tstop
  14SRC          1.      60.      0.      0.          -1.      9999.
BLANK End of source data.....!
C
C .....Output Request Data.....
C Bus-->Bus-->Bus-->Bus-->Bus-->Bus-->Bus-->Bus-->Bus-->Bus-->Bus-->
  FLT
BLANK End of output requests.....!
C
C Plot request Data.....
  2TRV in a very trivial circuit
C -----Graph type: 4(volts) 8(branch volts) 9(currents)
C : -----Units: 1(deg) 2(cyc) 3(sec) 4(msec) 5(microsec)
C :: -----Units per inch
C :: |-----Plot starting time
C :: |-----Plot stopping time
C :: |-----Value at bottom of vertical scale
C :: |-----Value at top of vertical scale
C :: |-----
C VV<-!<--!<--!<--!<---!Bus-->Bus-->Bus-->Bus-->Heading----->Vert axis----->
  144 1. 7.0 17.          FLT          TRVtrivial          PU TRV
BLANK End of Plot Request.....!
BLANK End of All Cases

```

(b) Input data.

Figure 10.1: (continued).

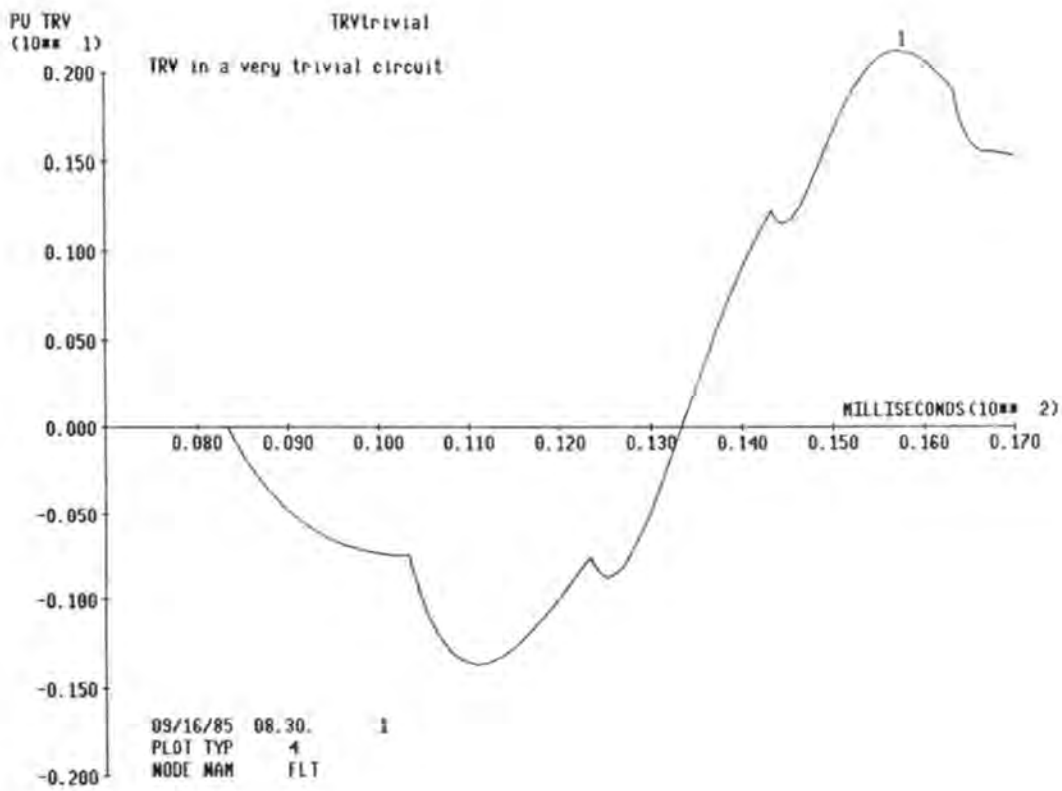

(c) Recovery voltage.

Figure 10.1: (continued).

Using the EMTP to calculate TRV's

Actual calculation of TRV's using the EMTP requires a great deal of care in establishing the model. The following points should be noted:

- It is important to represent all distributed lines connected to the bus, even relatively short ones.
- The manner in which these lines are terminated influences the TRV, particularly for the shortest of these lines.
- All capacitances at the breaker should be represented.

As an example of TRV calculations, consider the TRV after a solid 3 phase fault on the line side of the breaker on line 1-2. Represent: the generator at bus 3 as a Thevenin impedance, line 1-12 as a distributed line connected to an equivalent RL load, line 1-2 as an open line, and line 1-7 as a distributed line connected to a Thevenin equivalent. Figure 10.2 illustrates the example.

Problem 10.2: What do you think will happen to the TRV's shown if:

- (a) The line 1-12 is represented as open at the receiving end.
- (b) The line from 1-12 is not represented.
- (c) The line from 1 to 12 is not represented and a Thevenin equivalent at bus 1 is used, that is, line 1-7 is not represented in detail.

Problem 10.3: Explain the various "bumps" on Figure 10.2(d).

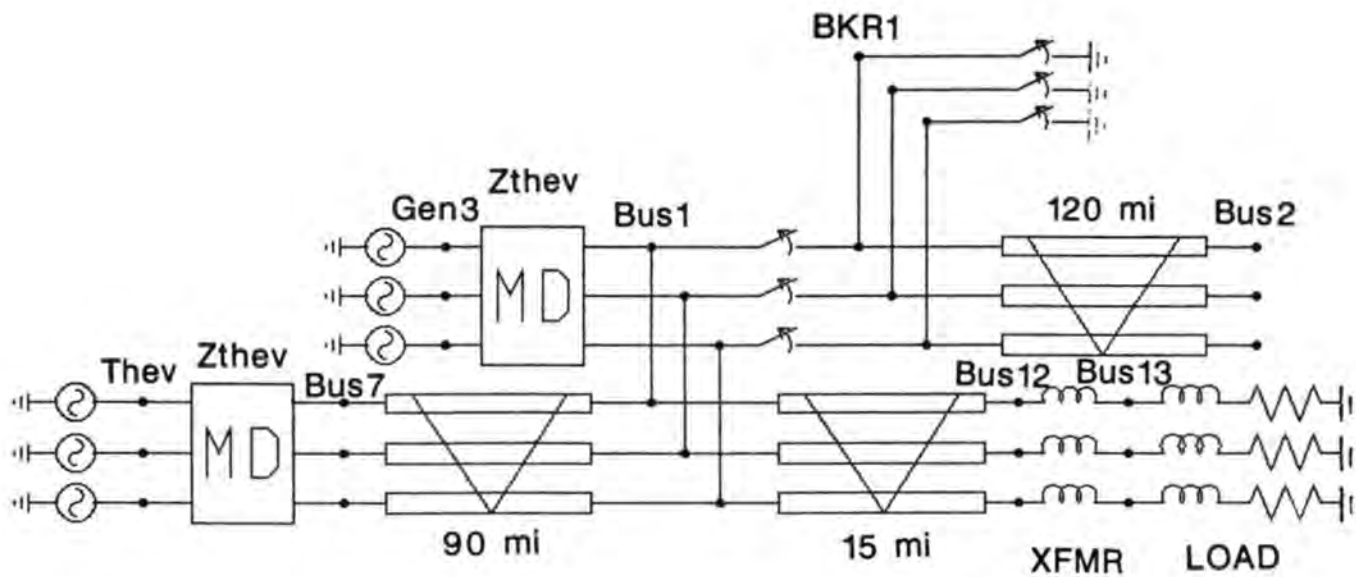

(a) Circuit diagram.

Figure 10.2: TRV for fault at bus 1, lines 1-7 and 7-12 represented.

```

BEGIN NEW DATA CASE
C-----Figure 10.2(b)-----
C TRV for bus 1 breaker for a 3 phase fault at bus 1,
C lines 1-7 and 1-12 represented
C ----dt<---tmax----->
10.E-6 25.E-3
C -Iprnt<---Iplot<---Idoubl<---KssOut<---MaxOut <---Icat
15 1 0 0 0 0
C
C .....Circuit data.....
C Bus-->Bus--><---R<---L<---R<---L<---R<---L
51THEVA BUS7A .13 23.71 0
52THEVB BUS7B .06 39.99 0
53THEVC BUS7C 0 0 0
51GEN3A BUS1A 0 84.2 0
52GEN3B BUS1B 0 154.4 0
53GEN3C BUS1C 0 0 0
C Bus-->Bus-->Bus-->Bus--><---R'<---L'<---C'<---len 0 0 0<---Blank----->0
-1BKR1A BUS2A 0.3167 3.222,00787 193.1 0 0 0 0
-2BKR1B BUS2B 0.0243 .9238 .0126 193.1 0 0 0 0
-3BKR1C BUS2C 0 0 0 0 0 0 0 0
C Bus-->Bus-->Bus-->Bus--><---R'<---L'<---C'<---len 0 0 0<---Blank----->0
-1BUS7A BUS1A 0.3167 3.222,00787 144.4 0 0 0 0
-2BUS7B BUS1B 0.0243 .9238 .0126 144.4 0 0 0 0
-3BUS7C BUS1C 0 0 0 0 0 0 0 0
C Bus-->Bus-->Bus-->Bus--><---R'<---L'<---C'<---len 0 0 0<---Blank----->0
-1BUS1A BUS12A 0.3167 3.222,00787 24.14 0 0 0 0
-2BUS1B BUS12B 0.0243 .9238 .0126 24.14 0 0 0 0
-3BUS1C BUS12C 0 0 0 0 0 0 0 0
C Bus-->Bus-->Bus-->Bus--><---R<---L<---C
BUS12ABUS13A 70.16 0
BUS12BBUS13BBUS12ABUS13A 0
BUS12CBUS13CBUS12ABUS13A 0
BUS13A 251.2 219.1 0
BUS13B BUS13A 0
BUS13C BUS13A 0
BLANK End of circuit data.....:
C
C .....Switch data.....
C Bus-->Bus--><---Tclose<---Topen<---Ia
BKR1A -1.E-3 9999. 0 0
BKR1B -1.E-3 9999. 0 0
BKR1C -1.E-3 9999. 0 0
BUS1A BKR1A -1.E-3 1.E-3 0 2
BUS1B BKR1B -1.E-3 1.E-3 0 2
BUS1C BKR1C -1.E-3 1.E-3 0 2
BLANK End of switch data.....:
C

```

(b) Input data.

Figure 10.2: (continued).

```

C .....Source data.....
C Bus-->I<Amplitude<Frequency<--T0:Phi0<---0=Phi0      <---Tstart<---Tstop
14GEN3A      187.79      60.      0.      0.      -1.      9999.
14GEN3B      187.79      60.     -120.     0.      -1.      9999.
14GEN3C      187.79      60.     120.     0.      -1.      9999.
C Bus-->I<Amplitude<Frequency<--T0:Phi0<---0=Phi0      <---Tstart<---Tstop
14THEVA      187.79      60.      0.      0.      -1.      9999.
14THEVB      187.79      60.     -120.     0.      -1.      9999.
14THEVC      187.79      60.     120.     0.      -1.      9999.
BLANK End of source data.....

C .....Output Request Data.....
C Bus-->Bus-->Bus-->Bus-->Bus-->Bus-->Bus-->Bus-->Bus-->Bus-->Bus-->Bus-->
BUS1A BKR1A BUS1B BKR1B BUS1C BKR1C BUS2A BUS2B
BLANK End of output requests.....

C
C Plot request Data.....
2TRV SLG fault at BUS1 for 120 mi line, line7, line12
C _____Graph type: 4(volts) 8(branch volts) 9(currents)
C : _____Units: 1(deg) 2(cyc) 3(sec) 4(msec) 5(microsec)
C :|_____Units per inch
C :| |_____Plot starting time
C :| | |_____Plot stopping time
C :| | | |_____Value at bottom of vertical scale
C :| | | | |_____Value at top of vertical scale
C :| | | | | |
C VV<-|<--|<--|<--|<--|Bus-->Bus-->Bus-->Bus-->Heading----->Vert axis----->
1842.5 0.0 25.-300.300.BUS1C BKR1C BUS1A BKR1A TRVbus1line712 BKR1A BKR1C KV
184.25 2.5 5.0-300.300.BUS1C BKR1C BUS1A BKR1A TRVbus1line712 BKR1A BKR1C KV
BLANK End of Plot Request.....
BLANK End of run Request

```

(b) Input data.

Figure 10.2: (continued).

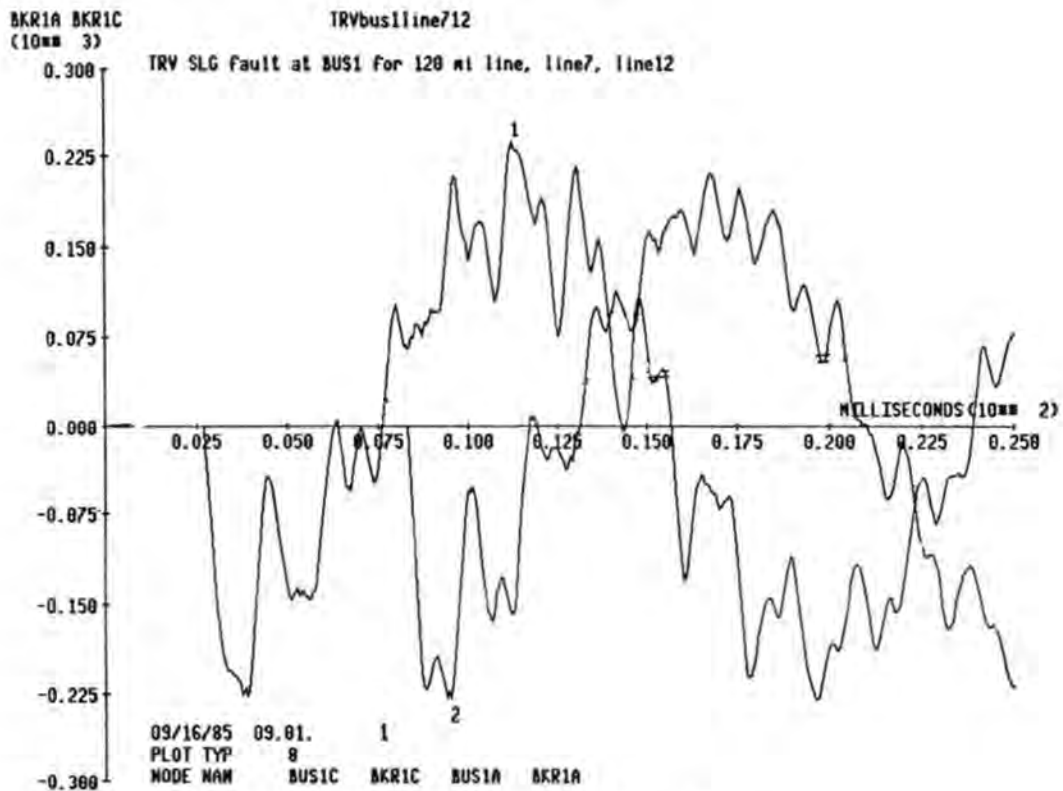

(c) TRV on phases c and a.

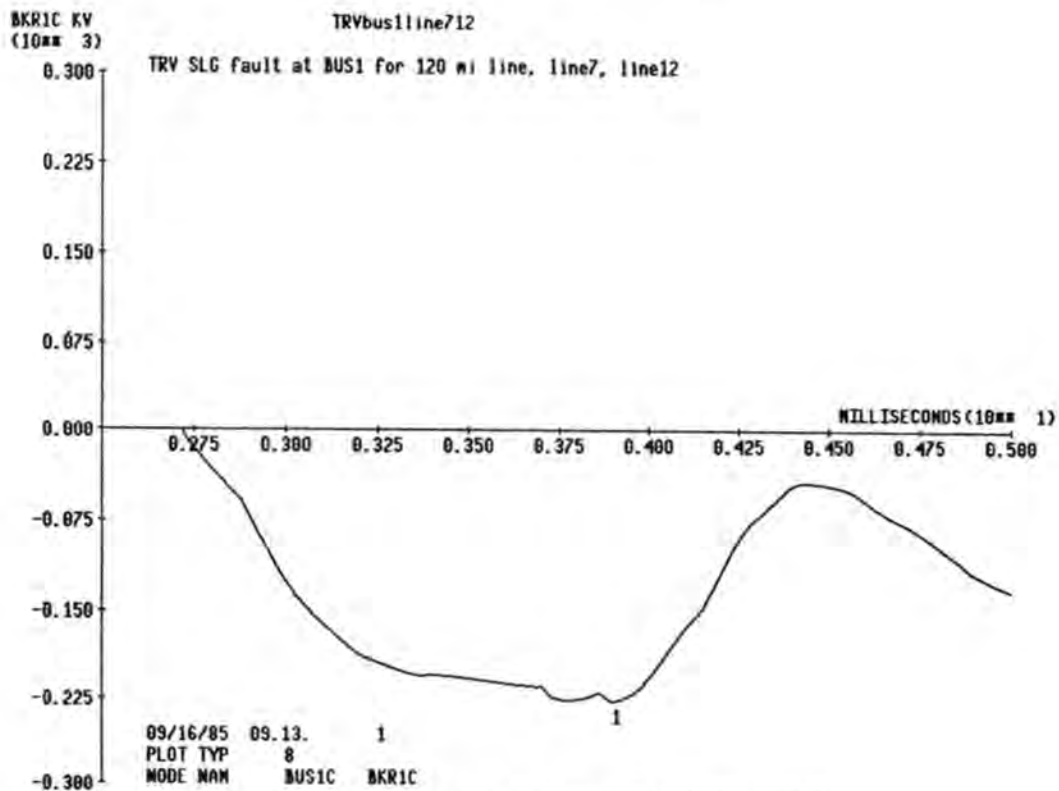

(d) TRV on phase c, expanded time scale.

Figure 10.2: (continued).

Other points of interest regarding TRV's are that the magnitude of the TRV is influenced by the total fault current capability of the system, and that the actual opening of the breaker occurs at a "normal" zero current crossing. If a breaker ever suddenly interrupts a current other than zero, this is said to be a "current chopping" problem. If a chopping occurs in mostly inductive circuits, very large overvoltages can result.

Because of the manner in which the EMTP works (in discrete time), there will always be a small amount of current chopping when a breaker opens. Figure 10.3(a) illustrates this point. If this current is flowing through an inductor, (Figure 10.3(b)) a numerical oscillation problem occur. Solutions to the problem are given in Figure 10.3(c)-(e). The problem of numerical oscillations is described in greater detail in the next section.

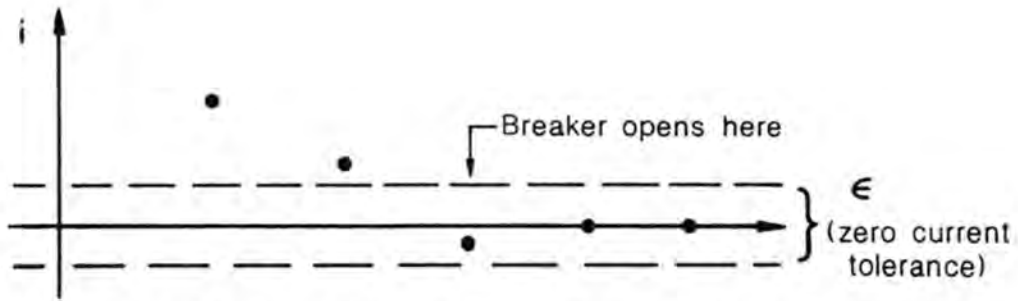

Opening normally occurs slightly off zero current.

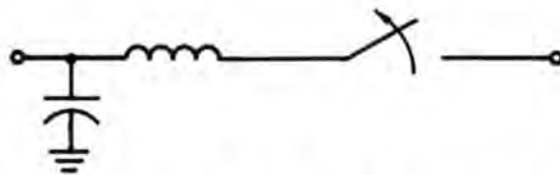

A circuit where this is a problem.

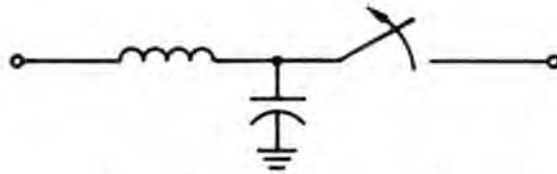

**A circuit less likely to have a problem
(unless C is very small).**

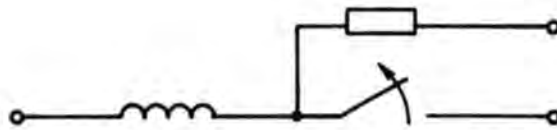

Another good solution.



Another way of solving the chopping problem.

Figure 10.3: Numerical current chopping can produce numerical oscillations.

Section 11

NUMERICAL OSCILLATIONS

The EMTP uses "trapezoidal integration" for its internal numerical computation. The main features of trapezoidal integration are its simplicity, numerical stability for "stiff" systems (those with widely differing eigenvalues), and its self-starting nature. On the other hand, trapezoidal integration suffers from numerical oscillations when used as a differentiator. As a result of this problem, it cannot be used without a careful regard for the system or circuit in which it is being employed.

This can be shown by changing the example of section 1B to a load de-energization instead of energization. Even though the opening of the switch traps enough current in the inductor to cause sustained numerical oscillations in the voltage across the breaker. This is illustrated in Figure 11.1.

The numerical oscillation can be explained best by differentiation of a step change. For example:

$$\text{inductor voltage} \quad v = L \frac{di}{dt}$$

$$\text{capacitor current} \quad i = C \frac{dv}{dt}$$

have numerical oscillations for step change in current for the inductor or voltage for the capacitor.

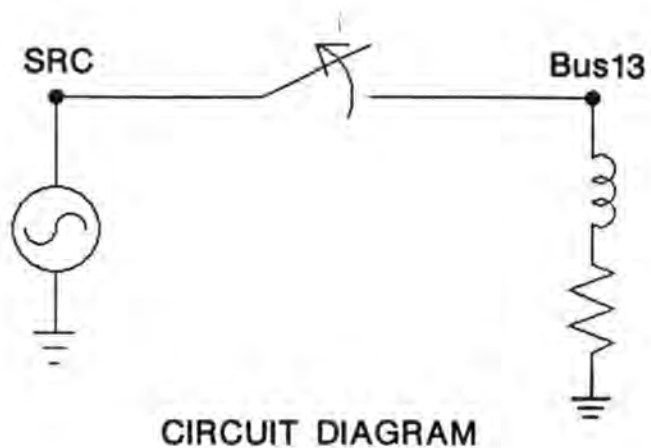

CIRCUIT DIAGRAM

(a) Circuit diagram.

Figure 11.1: De-energization of a pure RL load. Numerical oscillations will occur.

```

BEGIN NEW DATA CASE
C .....Figure 11.1(b).....
C DeEnergization of an RL load with more detailed source model, no damping ;
C ----dt<---tmax<----->
C 50.E-6 50.E-3
C -Iprnt<--Iplot<-Idoubl<-KssOut<-MaxOut <---Icat
C 15 1 0 0 0 0
C
C Circuit data.....
C Bus-->Bus-->Bus-->Bus--><----R<----L<----C 0
C BUS13 22.61 19.72 0
BLANK End of circuit data.....
C
C Switch data.....
C Bus-->Bus--><---Tclose<----Topen<-----Ie 0
C SRC BUS13 -1.E-3 1.E-3 2
BLANK End of switch data.....
C
C Source data.....
C Bus--><I<Amplitude<Frequency<--T0;Phi0<---0=Phi0 <---Tstart<----Tstop
14SRC 56.34 60. 0 0. -1. 9999.
BLANK End of source data.....
C
C Nodal Output Request Data.....
C Bus-->Bus-->Bus-->Bus-->Bus-->Bus-->Bus-->Bus-->Bus-->Bus-->Bus-->
SRC BUS13
BLANK End of output requests.....
C
C Plot request Data.....
C _____Graph type: 4(volts) 8(branch volts) 9(currents)
C : _____Units: 1(deg) 2(cyc) 3(sec) 4(msec) 5(microsec)
C : : _____Units per inch
C : : : _____Plot starting time
C : : : _____Plot stopping time
C : : : : _____Value at bottom of vertical axis (optional)
C : : : : _____Value at top of vertical axis (optional)
C VV<-;<--;<--;<--;<--;<--;<--;<--;<--;<--;<--;<--;<--;<--;<--;<--;<--;<--;<-->
184 5. 0.0 50.-100.100.SRC BUS13 EnTh 200MVA.95pfKVolts
BLANK End of Plot Request Data.....

```

(b) input data.

Figure 11.1: (continued).

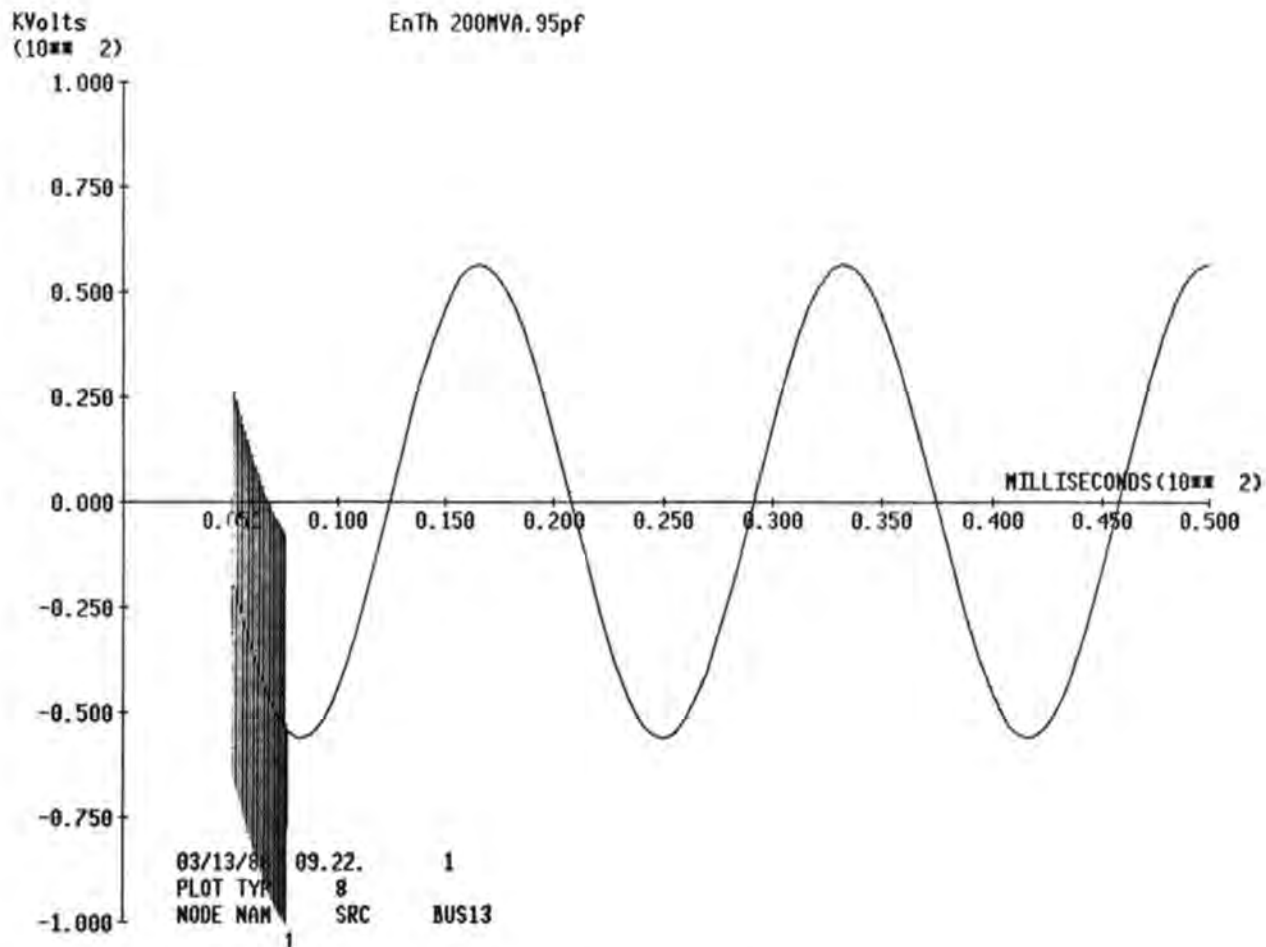

(c) Breaker voltage. Notice numerical oscillations. These are averaged out by the EMTP after 50 oscillations, but they continue internally.

Figure 11.1: (continued).

Represent this problem by

$$x = \frac{dy}{dt}$$

then

$$x(t) = -x(t-\Delta t) + \frac{2}{\Delta t} y(t) - \frac{2}{\Delta t} y(t-\Delta t)$$

if

$$x(t-\Delta t) = 0$$

and $y(t-\Delta t) = 0$ but $y(t) = 1.0$ for all other points in time

then

$$x(t) = \frac{2}{\Delta t}$$

Now look at $x(t+\Delta t)$

$$x(t+\Delta t) = -x(t) + \frac{2}{\Delta t} y(t+\Delta t) - \frac{2}{\Delta t} y(t)$$

or

$$x(t+\Delta t) = -\frac{2}{\Delta t}$$

The resulting oscillating waveform is illustrated in Figure 11.2. This waveform bears little resemblance to the time derivative of a unit step, which is an impulse function.

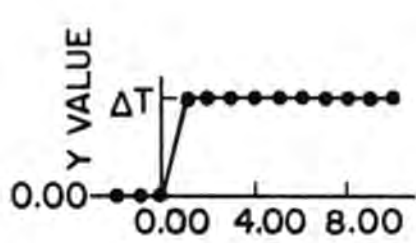

(a) Input

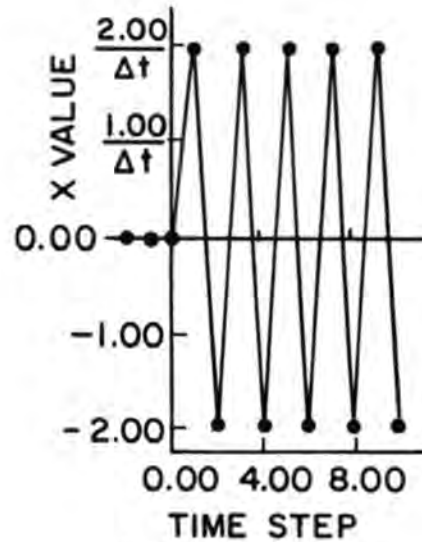

(b) Output

Figure 11.2: Result of differentiation of a step function.

If this step y took $2 \Delta t$ to go from $y = 0$ to $y = 1$ then the result would look closer to a step function as shown in Figure 11.3 since the area

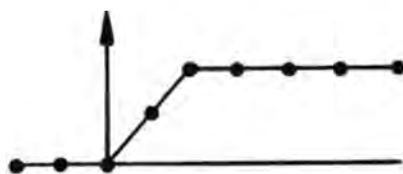

(a) Input

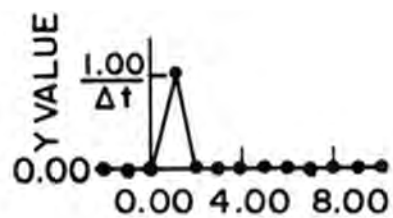

(b) Output

Figure 11.3: Differentiation of a slower step function.

$(\frac{1}{\Delta t} \times 2\Delta t) \frac{1}{2} = 1$ which is the area of a delta function.

There are two basic ways to stop or improve the problem of numerical oscillations, one is by adding physical components the other is to add damping to the trapezoidal method.

For example in the case of oscillations or switching out a LR load, the oscillations that result for a step change in inductor current could be prevented by adding small leakage capacitors in parallel with the LR load.

For the damping method a resistor is placed across all inductors of a value $R_d = \frac{L}{\alpha \Delta t}$ where α is a damping factor. When $\alpha = 0$ we have normal trapezoidal models. The error introduced by this damping resistor is shown in Figure 11.4. We note here that even ideal trapezoidal integration ($\alpha=0$) is subject to error, and that the error increases with Δt .

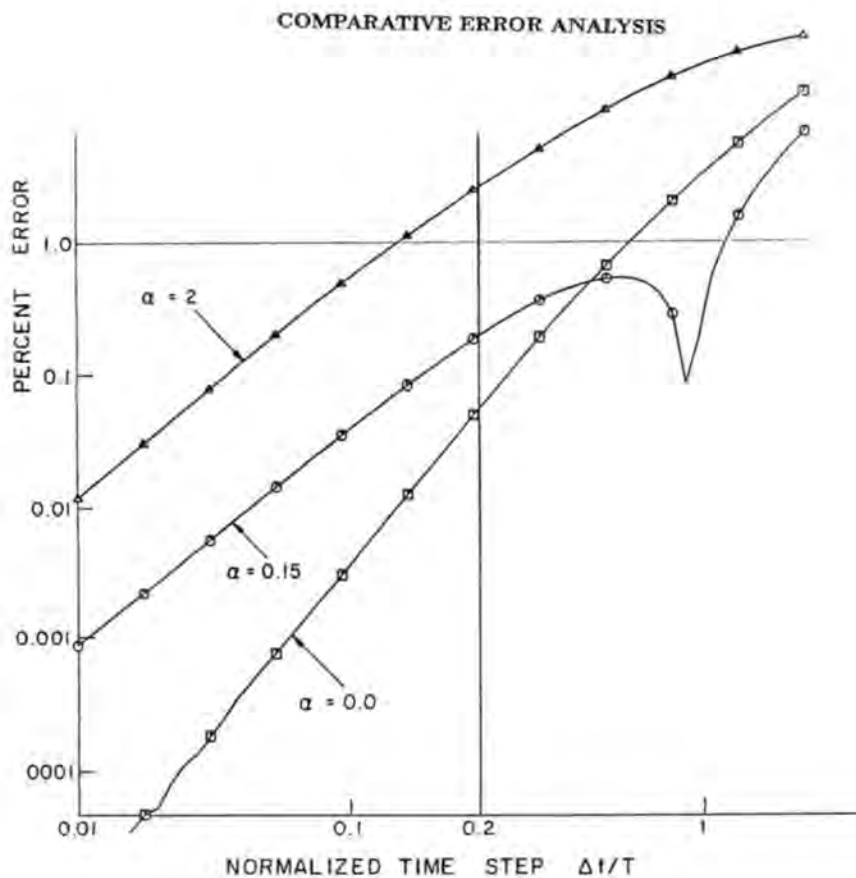

Figure 11.4: Percent Error over a Single Time Step versus Normalized Time Step for Trapezoidal Integration with Damping.

In general, if the time step of the integration is small, both ordinary trapezoidal and trapezoidal with damping give identical results. If the time step is made large enough, $\alpha = 0.15$ results in lower error than trapezoidal integration ($\alpha = 0$). The undesirable oscillations present in the trapezoidal simulation are eliminated after a short time, and the accuracy of the solution is excellent.

The way to implement this idea within the EMTP is to shunt every inductor (and to put in series with every capacitor) enough resistance so that the resulting time constant is about 6.7 times the time step Δt . For example if $\Delta t = 50\mu\text{s}$, we would add in parallel with a 19.72 mH resistor a resistance equal to:

$$R_d = \frac{L}{.15\Delta t} = 2630 \text{ ohms.}$$

The error introduced by this artificial resistance is less than the error introduced by the discretization process itself.

Problem 11.1: Modify the EMTD data for the de-energization of the RL load to eliminate the numerical oscillation by adding an appropriate shunt resistor. (If you do things correctly, the new simulation would look like Figure 11.5).

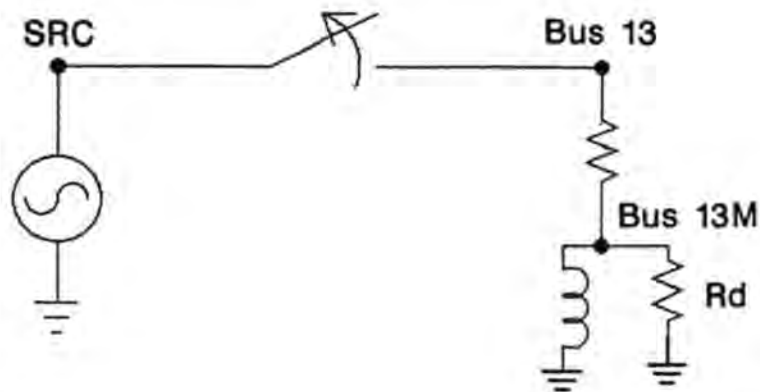

CIRCUIT DIAGRAM

(a) Circuit Diagram.

Figure 11.5: The de-energization of an inductor can produce numerical oscillations.

```

BEGIN NEW DATA CASE
C .....Figure 11.5(b).....
C DeEnergization of an RL load with more detailed source model, .15 damping :
C ----dt<---tmax<----->
C 50.E-6 50.E-3
C -Iprnt<---Iplot<-Idoubl<-KssOut<-MaxOut <---Icat
C 15 1 0 0 0 0
C
C Circuit data.....
C Bus-->Bus-->Bus-->Bus--><---R<---L<---C<---Ignore for now----->0
C BUS13 BUS13M 22.61 0
C BUS13M 19.72 0
C BUS13M 2630. 0
BLANK End of circuit data.....
C
C Switch data.....
C Bus-->Bus--><---Tclose<---Topen<---Ie 0
C SRC BUS13 -1.E-3 1.E-3 2
BLANK End of switch data.....
C
C Source data.....
C Bus--><I<Amplitude<Frequency<---T0!Phi0<---0=Phi0 <---Tstart<---Tstop
C 14SRC 56.34- 60. 0 0. -1. 9999.
BLANK End of source data.....
C
C Nodal Output Request Data.....
C Bus-->Bus-->Bus-->Bus-->Bus-->Bus-->Bus-->Bus-->Bus-->Bus-->Bus-->
C SRC BUS13
BLANK End of output requests.....
C
C Plot request Data.....
C _____Graph type: 4(volts) 8(branch volts) 9(currents) :
C | _____Units: 1(deg) 2(cyc) 3(sec) 4(msec) 5(microsec) :
C | | _____Units per inch :
C | | | _____Plot starting time :
C | | | | _____Plot stopping time :
C VV<-|<--|<--|<--|<---|<---|Bus-->Bus-->Bus-->Bus-->Heading----->Vert axis----->
C 184 5. 0.0 50.-100.100.SRC BUS13 EnTh 200MVA.95pfKVolts
BLANK End of Plot Request Data.....

```

(b) Input data.

Figure 11.5: (continued).

```

BEGIN NEW DATA CASE
C .....Figure 11.5(b) (continued).....
C DeEnergization of an RL load with more detailed source model, 1.0 damping  :
C -----dt<-----tmax<----->
C 50.E-6 50.E-3
C -Iprnt<--Iplot<-Idoubl<-KssOut<-MaxOut          <---Icat
C      15      1      0      0      0              0
C
C Circuit data.....
C Bus-->Bus-->Bus-->Bus--><---R<---L<---C          0
C BUS13 BUS13M      22.61          0
C BUS13M          19.72          0
C BUS13M          380.          0
BLANK End of circuit data.....:
C
C Switch data.....
C Bus-->Bus--><---Tclose<---Topen<---Ie          0
C SRC BUS13 -1.E-3 1.E-3          2
BLANK End of switch data.....:
C
C Source data.....
C Bus--><I<Amplitude<Frequency<---T0!Phi0<---0=Phi0      <---Tstart<---Tstop
14SRC      56.34 60. 0 0. -1. 9999.
BLANK End of source data.....:
C
C Nodal Output Request Data.....
C Bus-->Bus-->Bus-->Bus-->Bus-->Bus-->Bus-->Bus-->Bus-->Bus-->Bus-->
SRC BUS13
BLANK End of output requests.....:
C
C Plot request Data.....
C _____Graph type: 4(volts) 8(branch volts) 9(currents) :
C ; _____Units: 1(deg) 2(cyc) 3(sec) 4(msec) 5(microsec) :
C ; ; _____Units per inch :
C ; ; ; _____Plot starting time :
C ; ; ; _____Plot stopping time :
C VV<-!<--!<--!<---!<---!<---!Bus-->Bus-->Bus-->Bus-->Heading----->Vert axis----->
184 5. 0.0 50.-100.100.SRC BUS13          EnTh 200MVA.95pfKVolts
BLANK End of Plot Request Data.....:

```

(b) Input data.

Figure 11.5: (continued).

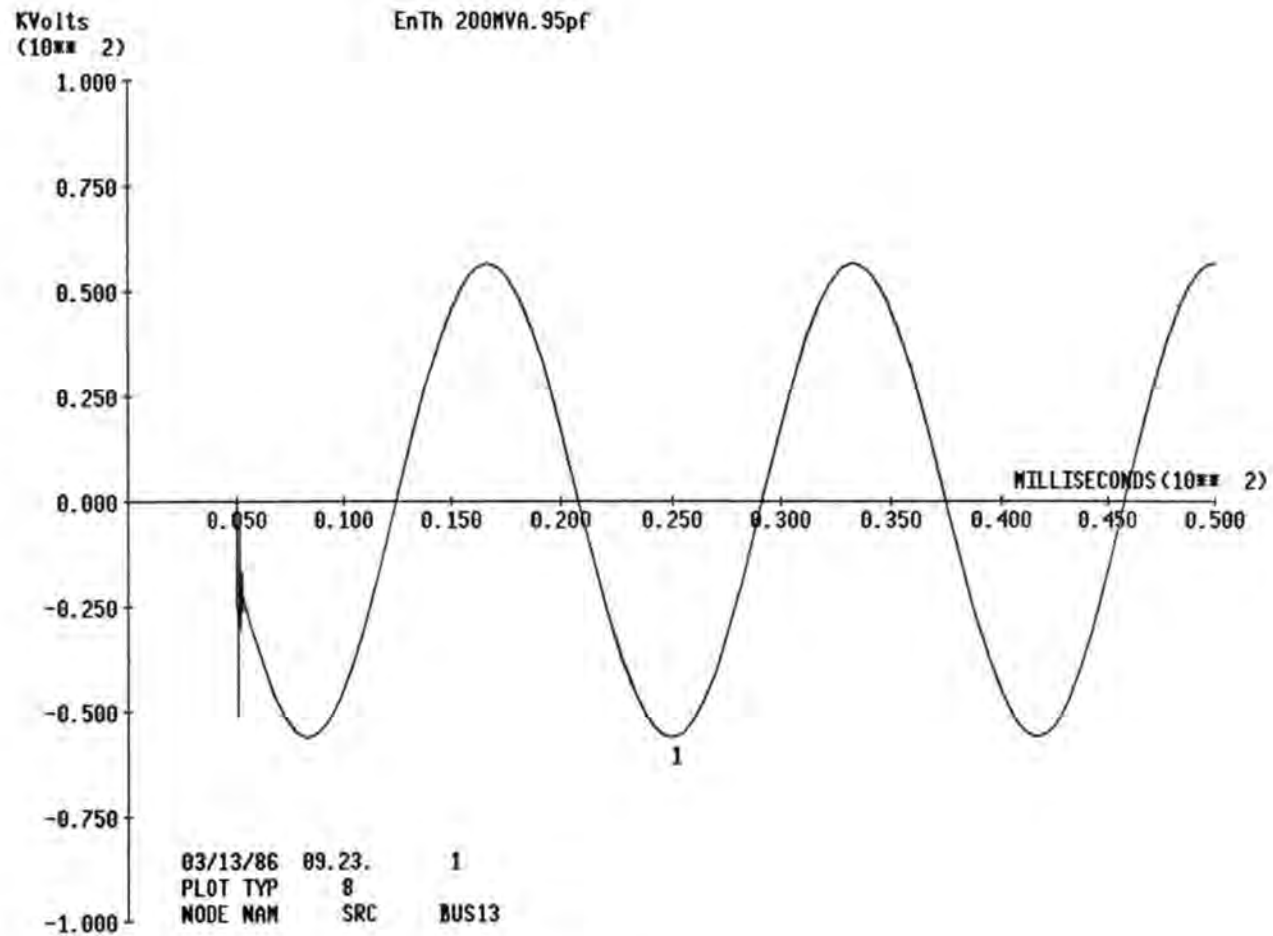

(c) Breaker voltage with $R_d = 2630\Omega$ ($\alpha = .15$).

Figure 11.5: (continued).

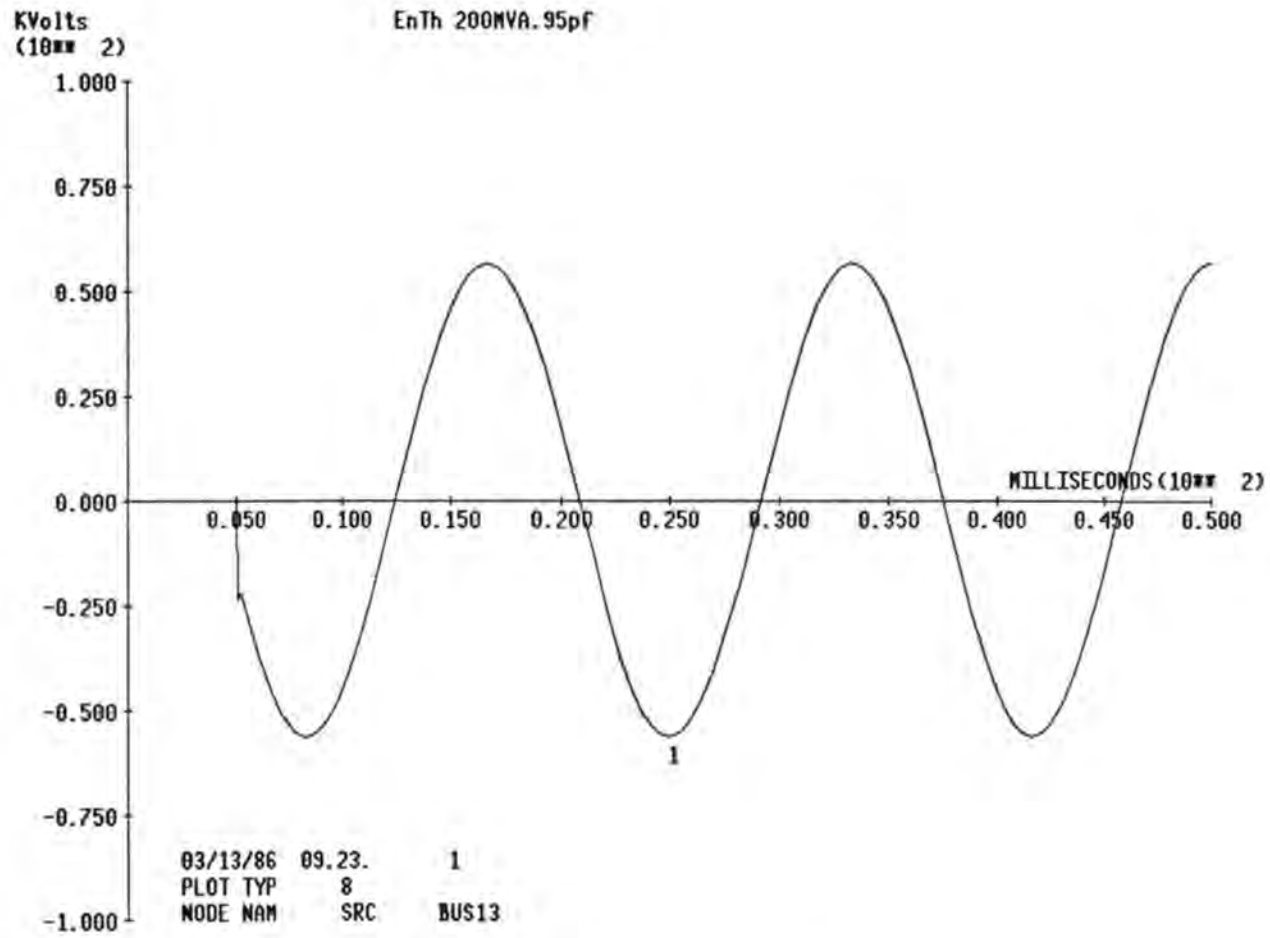

(d) Breaker voltage with $R_d = 380\Omega$ ($\alpha = 1$).

Figure 11.5: (continued).

Section 12

RECLOSING INTO TRAPPED CHARGE

The tendency of breakers to open only zero currents virtually insures that in capacitive circuits (including unloaded lines) the instant of breaker action will coincide with a peak voltage condition. Thus, a breaker opening will normally leave a capacitor (or a line) charged to its peak voltage. Unlike recovery voltages, reclosing of breakers can occur at any random instant. Depending on the exact instant of breaker action, overvoltages greater than 2 pu can develop. We explain the mechanism by which these overvoltages can develop by considering the very simple circuit in Figure 12.1. The analysis of this circuit is as follows:

While S is closed, the phasor voltage across the C can be obtained by voltage division from:

$$v_C = \frac{-1/\omega C}{\omega L - 1/\omega C} V \cos \omega t$$

or:

$$v_C = \frac{1}{1 - \omega^2 LC} V \cos \omega t$$

Define:

$$\omega_n = \frac{1}{\sqrt{LC}}$$

Then:

$$v_C = \frac{1}{1 - (\omega/\omega_n)^2} V \cos \omega t$$

If C is small enough, then $\omega_n \gg 1$ and we have:

$$v_c = V \cos \omega t$$

We can also calculate:

$$i = - \frac{V}{\frac{1}{\omega C} - \omega L} \sin \omega t$$

Regardless of the exact time of contact parting, effective opening of S will not occur till the first zero current crossing. This will only happen at $t = K \pi/\omega$, K integer. At any of these times, the capacitor voltage "trapped" is:

$$V_{\text{trap}} = \frac{1}{1 - (\omega/\omega_n)^2} V$$

Figure 12.2 illustrates the trapping phenomena. Assume that the breaker recloses at a later time. Assume further that the reclosing time is exactly half a cycle later. The transient solution that results is illustrated in Figure 12.3. It is easy to verify that the peak voltage after breaker reclosure will be approximately:

$$\begin{aligned} |v_{\text{peak}}| &= 3 v_{\text{trap}}, \\ &= \frac{3}{1 - (\omega/\omega_n)^2} V \end{aligned}$$

This represents an overvoltage in the capacitor of 3 per unit.

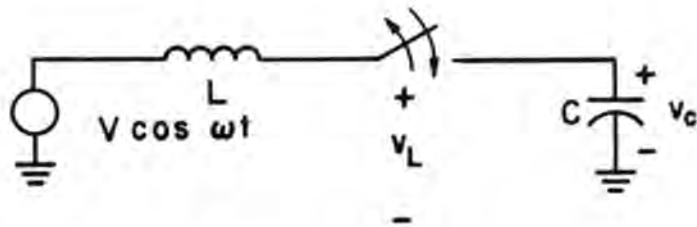

(a) The Circuit of Interest

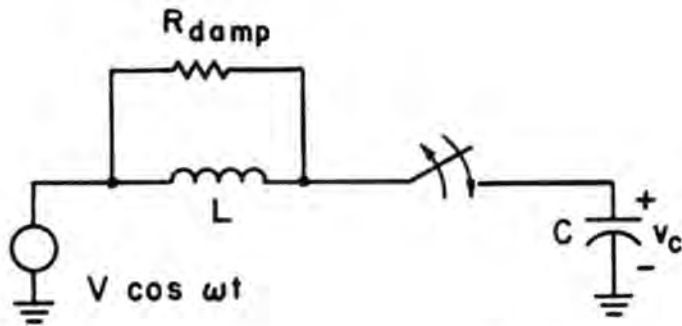

(b) Circuit modified to use EMTP.

(b) Circuit modified to use EMTP

Figure 12.1: Circuit to Illustrate Reclosing into Trapped Charges

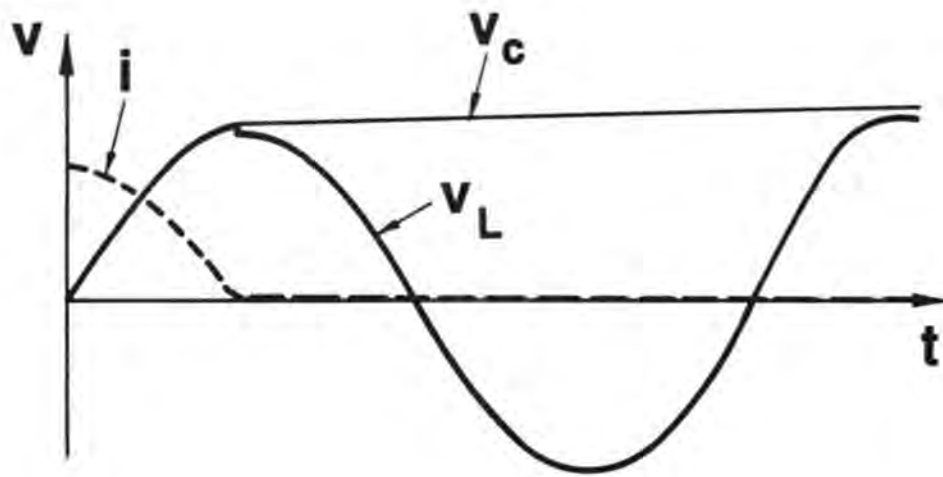

Figure 12.2: Trapping of Charge in a Capacitor

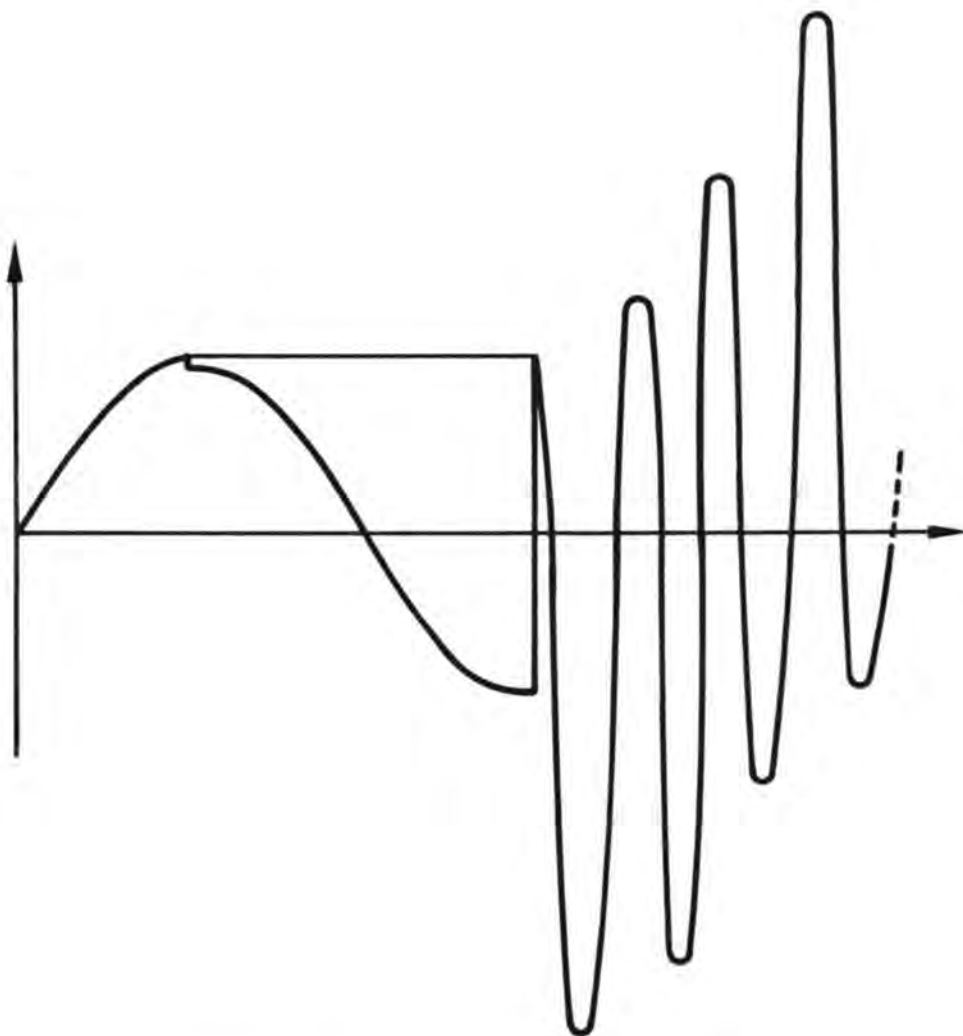

Figure 12.3: Reclosing into Trapped Charge

Figure 12.4(c) illustrated the input data required to simulate the problem at hand using the EMTP for a case where:

$$L = 1 \text{ mH}$$

$$C = 10 \text{ } \mu\text{F}$$

$$V = 1$$

Notice that an oscillation damping resistor of value:

$$R_{\text{damp}} = (L/\Delta t)/.15 = 667\Omega$$

was added. Without it, severe numerical oscillations would occur. However, because of it we see a slight damping of the LC oscillations after reclosure. Results are shown in Figure 12.4(b)

Problem 12.1: Compare the EMTF results from Figure 12.4 with hand calculated values.

In particular, compare:

	EMTF	Calculated
V_{trap}		
V_{peak}		
ω_{n}		

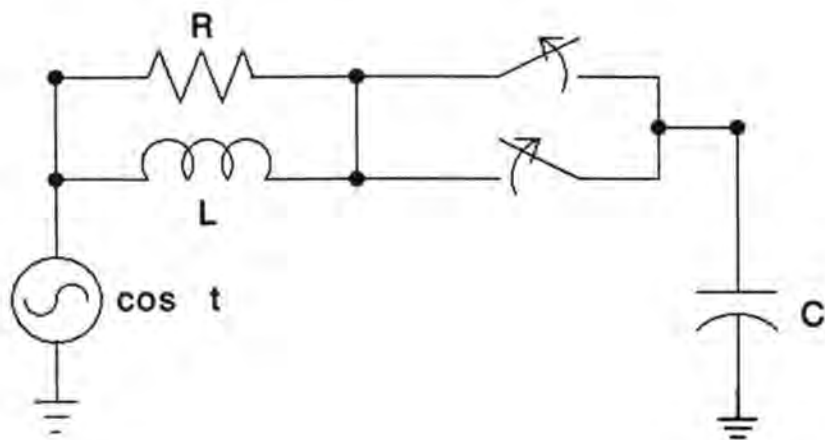

(a) Circuit Diagram.

Figure 12.4: Trapped charge in a trivial circuit. Two breakers are used to model opening and reclosing.

```

BEGIN NEW DATA CASE
C -----Figure 12.4(b)-----
C Trapped charge in a trivial circuit. ;
C -----dt<---tmax<----->
C 10.E-6 20.E-3
C -Iprnt<---Iplot<---Idoubl<---KssOut<---MaxOut <---Icat
C 15 1 0 0 0 2
C
C .....Circuit data.....
C Bus-->Bus-->Bus-->Bus--><---R<---L<---C 0
C SRC BKR 1. 0
C SRC BKR 667. 0
C CAP 10. 0
BLANK End of circuit data.....;
C
C .....Switch data.....
C Bus-->Bus--><---Tclose<---Topen<---Ie 0
C BKR CAP -1.E-3 1.E-3 0
C CAP BKR 16.67E-3 9999. 0
BLANK End of switch data.....;
C
C .....Source data.....
C Bus--><I<Amplitude<Frequency<---T0!Phi<---0=Phi <---Tstart<---Tstop
14SRC 1. 60. 180. 0. -1. 9999.
BLANK End of source data.....;
C
C .....Output Request Data.....
C Bus-->Bus-->Bus-->Bus-->Bus-->Bus-->Bus-->Bus-->Bus-->Bus-->
C BKR CAP
BLANK End of output requests.....;
C
C Plot request Data.....
2Trapped charge in a very trivial circuit
C -----Graph type: 4(volts) 8(branch volts) 9(currents) .
C ; -----Units: 1(deg) 2(cyc) 3(sec) 4(msec) 5(microsec) .
C ;|-----Units per inch .
C ;| |-----Plot starting time .
C ;| |-----Plot stopping time .
C ;| | |-----Value at bottom of vertical scale .
C ;| | |-----Value at top of vertical scale .
C ;| | | .
C VV<---<---<---<---<---<---Bus-->Bus-->Bus-->Bus-->Heading----->Vert axis----->
144 2. 0.0 20. -3.0 3.0BKR CAP TrapTrivial PU Voltage
BLANK End of Plot Request.....;
BLANK End of All Cases

```

(b) Input data.

Figure 12.4: (continued).

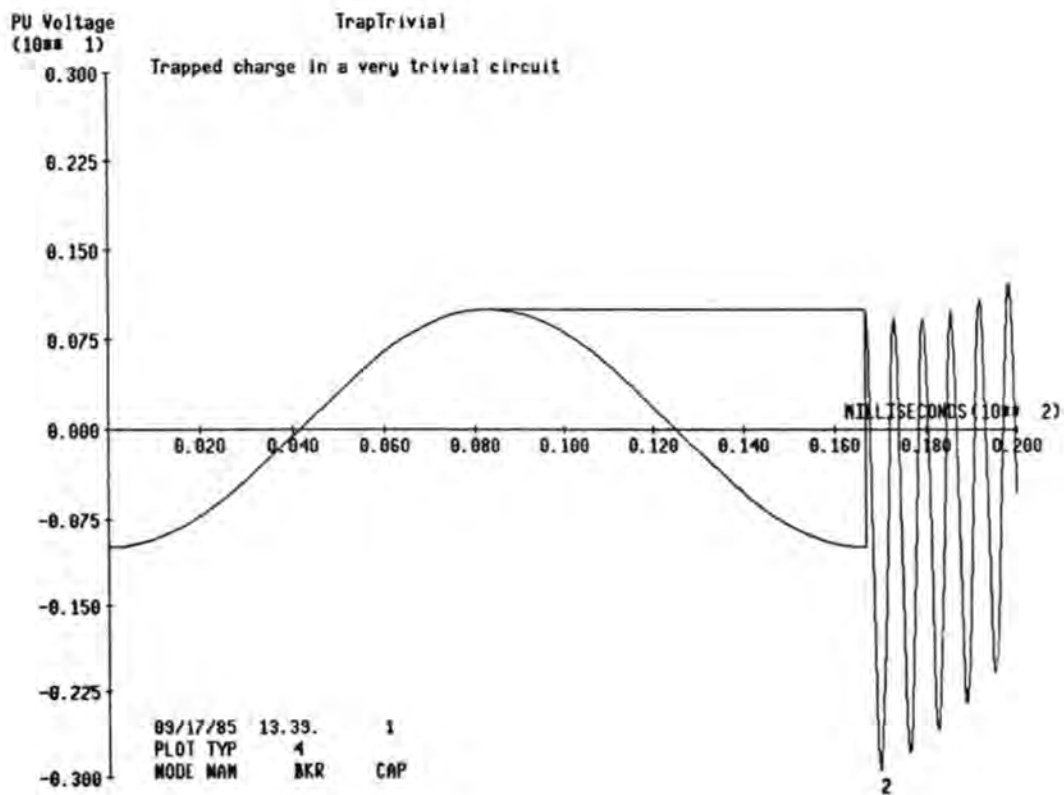

(c) Capacitor voltage.

Figure 12.4: (continued).

Using the EMTP to study reclosing into trapped charges

Use of the EMTP to calculate overvoltages due to trapped charges in practical systems requires a number of considerations.

- How to represent and trap the charge.
- Selection of trapped charge values, if more than one trapped charge is involved.
- Selection of reclosing times for each phase.

There are two very different ways of trapping a charge in the EMTP:

- Use the override "initial conditions" feature of the EMTP.
- Let the natural opening action of switches trap a charge.

The first method saves simulation time but is more cumbersome and less general. We only discuss the second method. To do this, proceed to initialize the EMTP simulation with all switches closed, and then open them in some sequence to establish a charge. Note that for three phase systems the exact instant and sequence of phase of breaker action will influence the amount and polarity of a trapped charge.

Problem 12.2: Given a three phase sinusoidal Y connected source at bus SRC connected to three Y connected capacitors at bus CAP by three switches, specify switch opening times to trap charges of polarity:

(a) + + +

(b) + - +

(c) - - +

Trapping a charge in a transmission line is almost the same as trapping a charge in a capacitor, except that the opening of a breaker will establish small transients in the line before the phases settle to an average dc charge value. These oscillations are usually small and can be neglected. Figure 12.5 illustrates the trapping of a charge on the 120 mile line from bus 1 to bus 2. The exact instant of reclosure of each phase affects the magnitude of the overvoltages that result. Once a certain reclosing time is selected, a simulation of the resulting reclosing overvoltages can be performed. Figure 12.6 illustrates a case where this has been done.

As mentioned earlier, the exact moment of reclosure of each phase greatly influences the magnitude of the reclosing overvoltage magnitudes. These overvoltages cannot normally be controlled by playing with the timing of the breaker closure, since this time is considered random. Thus it becomes possible to ask not for a reclosing overvoltage but rather for the statistical distribution of these overvoltages. The EMTP has capabilities to perform such statistical studies, but these are not described here.

Problem 12.3: An important way of controlling overvoltages is the use of pre-insertion resistors in breakers. Modify the data in Figure 12.6 to study the effect of 300 ohm pre-insertion resistors that remain in service for half a cycle each (8 ms) before full breaker closure occurs. If you do things right, you will obtain the results in Figure 12.7.

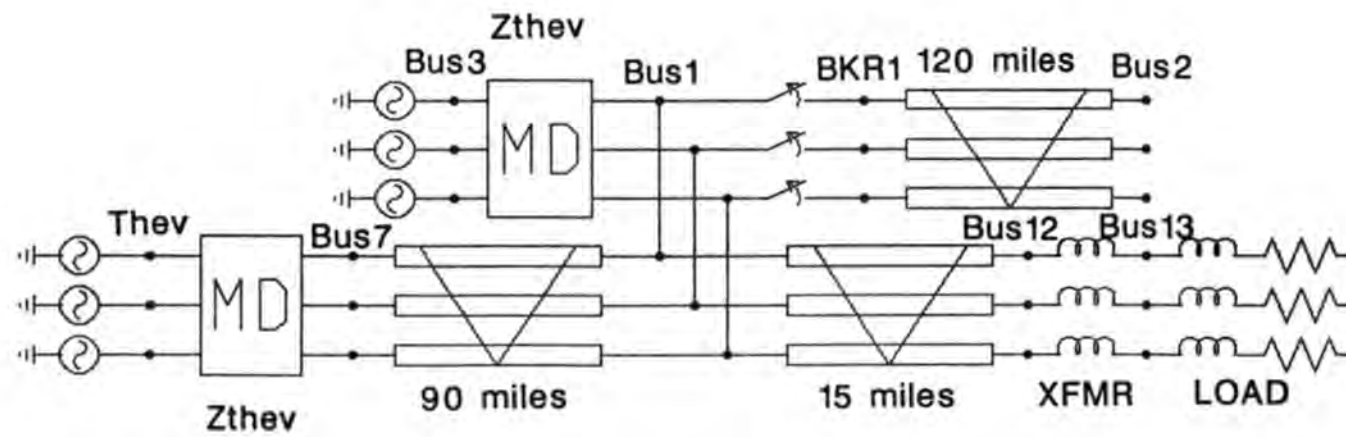

(a) Circuit diagram.

Figure 12.5: Trapping of charge on line 1-2 by opening of breaker.

```

BEGIN NEW DATA CASE
C -----Figure 12.5(b)-----
C Trapped charge in the line from bus 1 to bus 2. ;
C ----dt<----tmax<----->
C 20.E-6 25.E-3
C -Iprnt<--Iplot<-Idoub<-KssOut<-MaxOut <---Icat
C 15 1 0 0 0 0
C
C .....Circuit data.....
C Bus-->Bus--><-----R<-----L<-----R<-----L<-----R<-----L
51THEVA BUS7A .13 23.71 0
52THEVB BUS7B .06 39.99 0
53THEVC BUS7C 0 0 0
51GEN3A BUS1A 0 84.2 0
52GEN3B BUS1B 0 154.4 0
53GEN3C BUS1C 0 0 0
C Bus-->Bus-->Bus-->Bus--><---R'<---L'<---C'<---len 0 0 0<---Blank----->0
-1BKR1A BUS2A 0.3167 3.222.00787 193.1 0 0 0 0
-2BKR1B BUS2B 0.0243 .9238 .0126 193.1 0 0 0 0
-3BKR1C BUS2C 0 0 0 0 0 0 0 0
C Bus-->Bus-->Bus-->Bus--><---R'<---L'<---C'<---len 0 0 0<---Blank----->0
-1BUS7A BUS1A 0.3167 3.222.00787 144.4 0 0 0 0
-2BUS7B BUS1B 0.0243 .9238 .0126 144.4 0 0 0 0
-3BUS7C BUS1C 0 0 0 0 0 0 0 0
C Bus-->Bus-->Bus-->Bus--><---R'<---L'<---C'<---len 0 0 0<---Blank----->0
-1BUS1A BUS12A 0.3167 3.222.00787 24.14 0 0 0 0
-2BUS1B BUS12B 0.0243 .9238 .0126 24.14 0 0 0 0
-3BUS1C BUS12C 0 0 0 0 0 0 0 0
C Bus-->Bus-->Bus-->Bus--><---R<---L<---C
BUS12ABUS13A 70.16 0
BUS12BBUS13BBUS12ABUS13A 0
BUS12CBUS13CBUS12ABUS13A 0
BUS13A 251.2 219.1 0
BUS13B BUS13A 0
BUS13C BUS13A 0
BLANK End of circuit data.....:
C
C .....Switch data.....
C Bus-->Bus--><---Tclose<---Topen<---Ie 0
BUS1A BKR1A -1.E-3 1.E-3 0 1
BUS1B BKR1B -1.E-3 1.E-3 0 1
BUS1C BKR1C -1.E-3 1.E-3 0 1
BLANK End of switch data.....:
C
C .....Source data.....
C Bus-->I<Amplitude<Frequency<---T0!Phi0<---0=Phi0 <---Tstart<---Tstop
14GEN3A 187.79 60. 0. 0. -1. 9999.
14GEN3B 187.79 60. -120. 0. -1. 9999.
14GEN3C 187.79 60. 120. 0. -1. 9999.
14THEVA 187.79 60. 0. 0. -1. 9999.
14THEVB 187.79 60. -120. 0. -1. 9999.
14THEVC 187.79 60. 120. 0. -1. 9999.
BLANK End of source data.....:
C
C .....Output Request Data.....
C Bus-->Bus-->Bus-->Bus-->Bus-->Bus-->Bus-->Bus-->Bus-->Bus-->Bus-->
BUS1A BUS2A BUS2B BUS2C
BLANK End of output requests.....:

```

(b) Input data.

Figure 12.5: (continued).

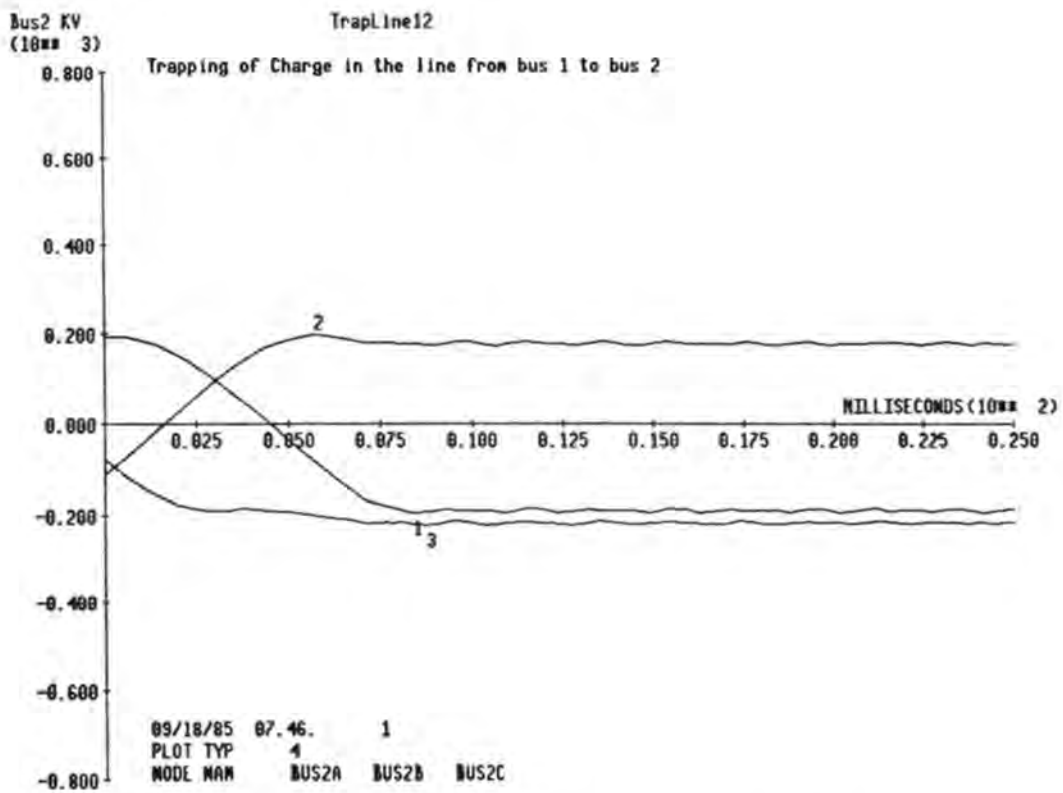

(c) Trapped voltages on line. Notice slight ripple.

Figure 12.5: (continued).

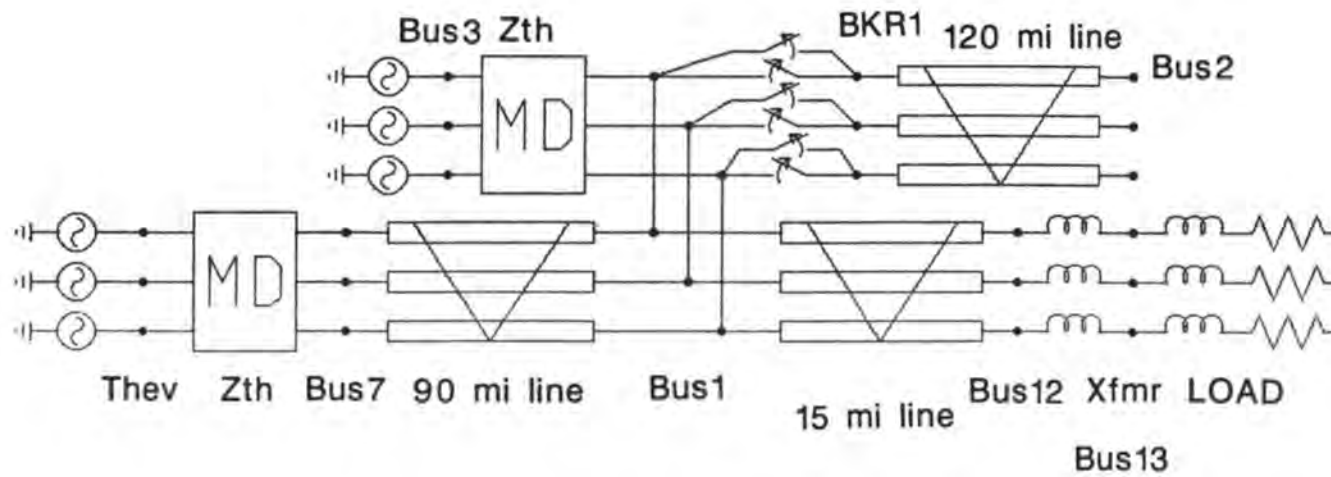

(a) Circuit diagram.

Figure 12.6: Reclosing into a trapped charge on line 1-2.

```

BEGIN NEW DATA CASE
C -----Figure 12.6(b)-----
C Reclosing of the line from bus 1 to bus 2.
C -----dt-----tmax----->
C 20.E-6 20.E-3
C -Iprnt<---Iplot<---Idoub<---KssOut<---MaxOut          <---Icat
C      15      1      0      0      0                      0
C
C .....Circuit data.....
C Bus-->Bus--><-----R<-----L<-----R<-----L<-----R<-----L
51THEVA BUS7A      .13      23.71
52THEVB BUS7B      .06      39.99
53THEVC BUS7C
51GEN3A BUS1A      0      84.2
52GEN3B BUS1B      0      154.4
53GEN3C BUS1C
C Bus-->Bus-->Bus-->Bus--><---R'<---L'<---C'<---len 0 0 0<---Blank----->0
-1BKR1A BUS2A      0.3167 3.222.00787 193.1 0 0 0
-2BKR1B BUS2B      0.0243 .9238 .0126 193.1 0 0 0
-3BKR1C BUS2C
C Bus-->Bus-->Bus-->Bus--><---R'<---L'<---C'<---len 0 0 0<---Blank----->0
-1BUS7A BUS1A      0.3167 3.222.00787 144.4 0 0 0
-2BUS7B BUS1B      0.0243 .9238 .0126 144.4 0 0 0
-3BUS7C BUS1C
C Bus-->Bus-->Bus-->Bus--><---R'<---L'<---C'<---len 0 0 0<---Blank----->0
-1BUS1A BUS12A     0.3167 3.222.00787 24.14 0 0 0
-2BUS1B BUS12B     0.0243 .9238 .0126 24.14 0 0 0
-3BUS1C BUS12C
C Bus-->Bus-->Bus-->Bus--><---R<---L<---C
BUS12ABUS13A      70.16
BUS12BBUS13BBUS12ABUS13A
BUS12CBUS13CBUS12ABUS13A
BUS13A      251.2 219.1
BUS13B      BUS13A
BUS13C      BUS13A
BLANK End of circuit data.....:
C
C .....Switch data.....
C Bus-->Bus--><---Tclose<---Topen<---Ie
BUS1A BKR1A      -1.E-3      1.E-3      0
BUS1B BKR1B      -1.E-3      1.E-3      0
BUS1C BKR1C      -1.E-3      1.E-3      0
BKR1A BUS1A      12.E-3      9999.      0
BKR1B BUS1B      13.E-3      9999.      0
BKR1C BUS1C      14.E-3      9999.      0
BLANK End of switch data.....:
C
C .....Source data.....
C Bus--><I<Amplitude<Frequency<---T0:Phi0<---0=Phi0          <---Tstart<---Tstop
14GEN3A      187.79      60.      0.      0.      -1.      9999.
14GEN3B      187.79      60.     -120.      0.      -1.      9999.
14GEN3C      187.79      60.     120.      0.      -1.      9999.
14THEVA      187.79      60.      0.      0.      -1.      9999.
14THEVB      187.79      60.     -120.      0.      -1.      9999.
14THEVC      187.79      60.     120.      0.      -1.      9999.
BLANK End of source data.....:
C
C .....Output Request Data.....
C Bus-->Bus-->Bus-->Bus-->Bus-->Bus-->Bus-->Bus-->Bus-->Bus-->Bus-->

```

(b) Input data.

Figure 12.6: (continued).

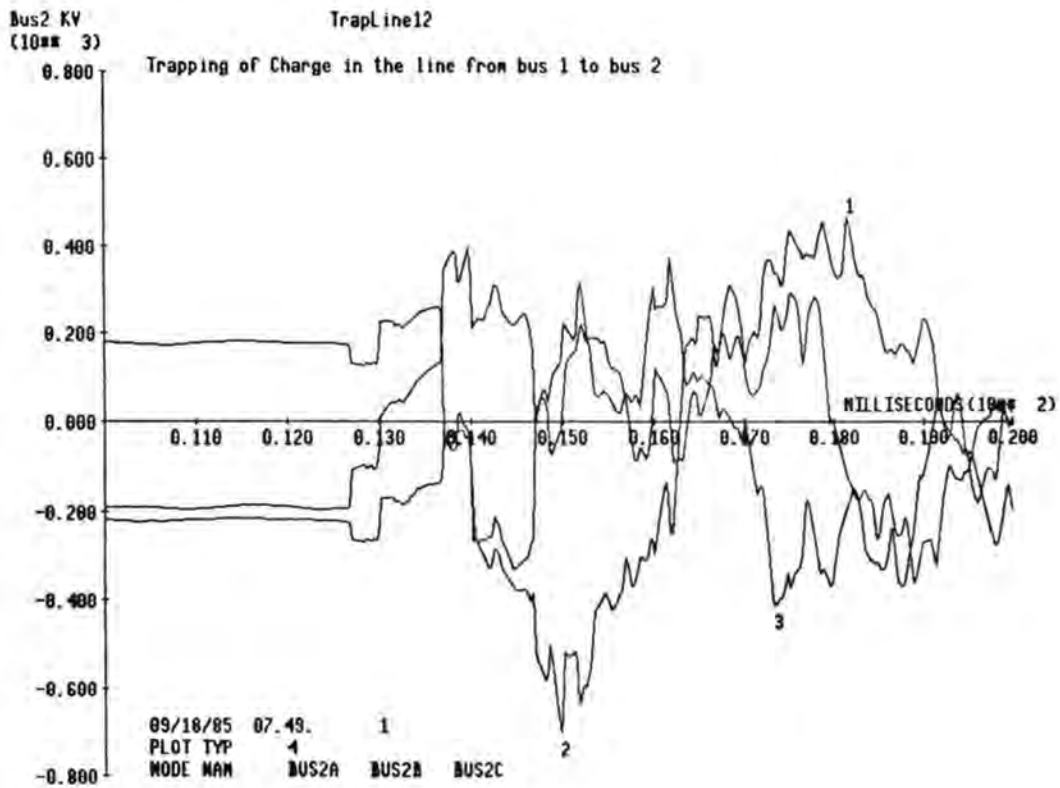

(c) Reclosing overvoltages at bus 2.

Figure 12.6: (continued).

12-20

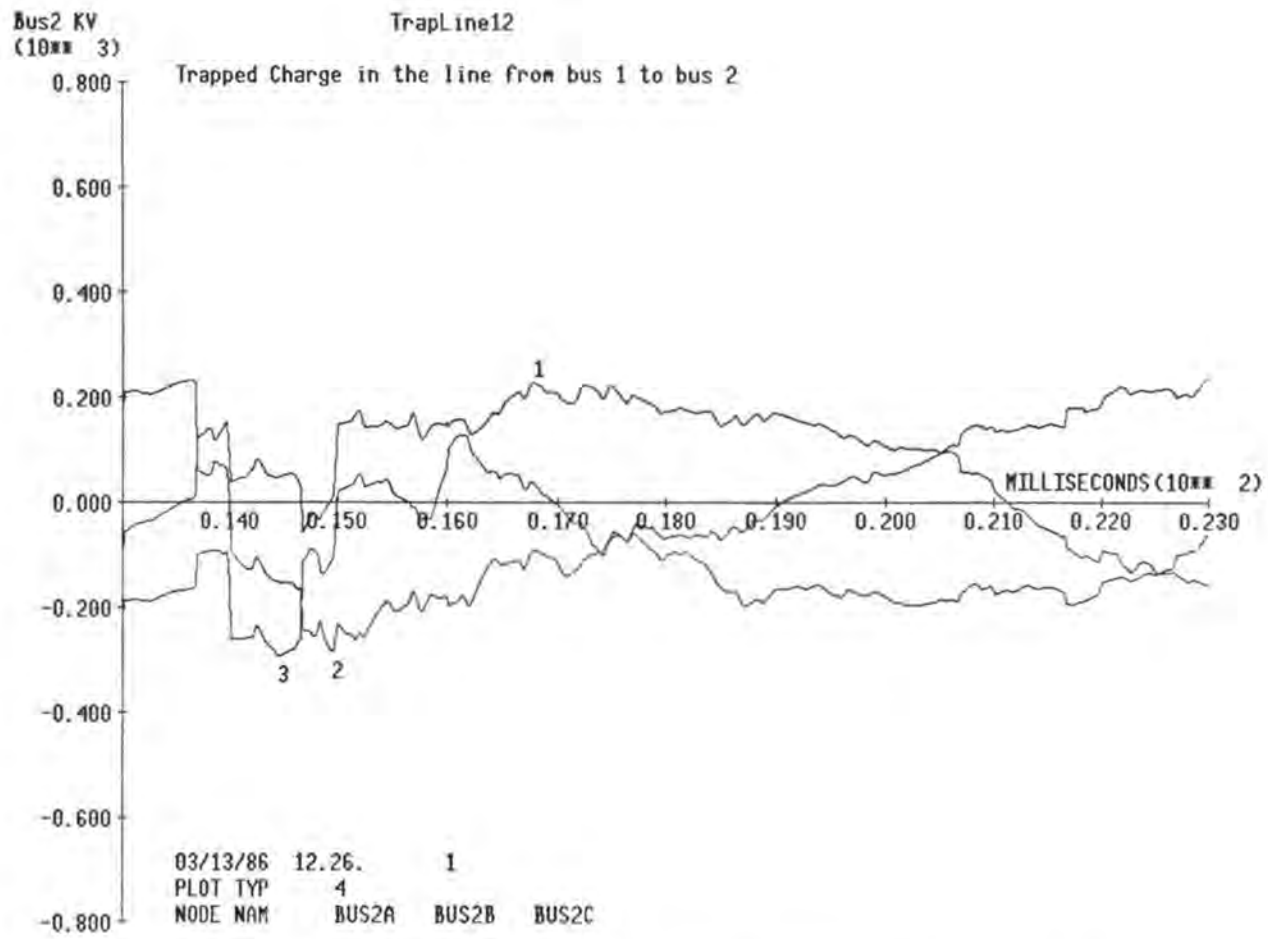

Figure 12.7: The effect of 300 Ω pre-insertion (see problem 12.3).

Section 13

CAPACITOR SWITCHING

A problem closely related to reclosing into trapped charge is the entire issue of capacitors. The capacitor switching problem is closely related to the trapped charge problem described previously. Studies that can be performed with the EMTP include:

- Studies of currents that result upon breaker energization.
- Studies of TRV on breakers under a variety of breaker operating sequences.

Figures 13.1 to 13.3 illustrate typical voltage waveforms that result from capacitor bank de-energization. Figure 13.1 illustrates the case of all breakers opening correctly. Phase c opens first, followed by phases a and b. Figure 13.2 illustrates what happens if the breakers in phases b and a get "stuck" and do not open at their next zero current crossing. Figure 13.3 illustrates the case of breaker "b" stuck. Notice the extremely large recovery voltages that can develop in this case.

Problem 13.1: Prepare EMTP data to study in more detail the problem of energization and de-energization of the ungrounded Y bank at bus 1.

- (a) Assuming simultaneous breaker energization.
- (b) Assuming a permanently stuck open breaker in one phase.
- (c) Assuming simultaneous breaker de-energization.
- (d) Assuming de-energization with a stuck breaker.

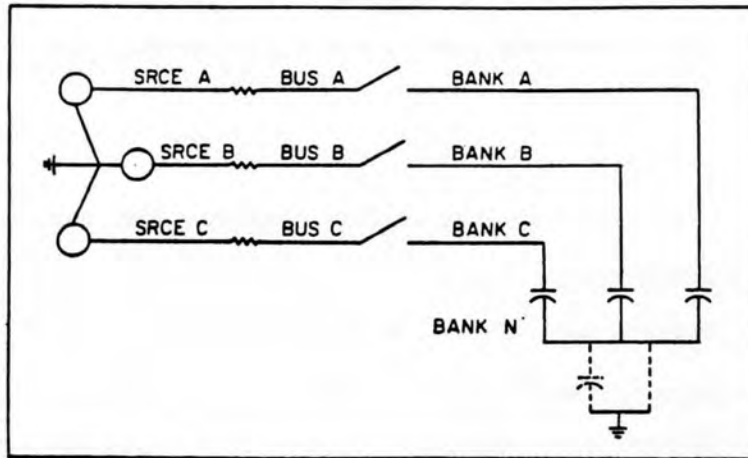

(a) Circuit diagram.

Figure 13.1: Disconnection of a three phase Y-connected capacitor bank. Phase C opens first, followed by phases A and B. TRV is differences between voltages.

```

BEGIN NEW DATA CASE
C -----Figure 13.1(b)-----
C Opening of a breaker in a capacitor bank
C ----dt<----tmax<-Xopt
  50.E-6  50.E-3  60.
C -lprnt<--lplot<-ldoubl<-KssOut<-MaxOut         <---Icat
  15      1      0      0      0                  0
C
C .....Circuit data.....
C Bus-->Bus-->Bus-->Bus--><----R<----L<----C      0
  SRCEA BUSA                .001                0
  SRCEB BUSB  SRCEA BUSA                0        0
  SRCEC BUSC  SRCEA BUSA                0        0
  BANKA BANKN                1000.             2
  BANKB BANKN BANKA BANKN                2
  BANKC BANKN BANKA BANKN                2
  BANKN                .1                    0
BLANK End of circuit data.....:
C
C .....Switch data.....
C Bus-->Bus--><---Tclose<---Topen<-----Ie      0
  BUSA  BANKA  -1.E-3  1.E-3    0            2
  BUSB  BANKB  -1.E-3  1.E-3    0            2
  BUSC  BANKC  -1.E-3  1.E-3    0            2
BLANK End of switch data.....:
C
C .....Source data.....
C Bus--><I<Amplitude<Frequency<---10;Phi0<---0=Phi0    <---Tstart<---Tstop
14SRCEA      1.      60.      0.      0.      -1.      9999.
14SRCEB      1.      60.     -120.     0.      -1.      9999.
14SRCEC      1.      60.     120.     0.      -1.      9999.
BLANK End of source data.....:
C
C .....Output Request Data.....
C Bus-->Bus-->Bus-->Bus-->Bus-->Bus-->Bus-->Bus-->Bus-->Bus-->Bus-->Bus-->
  SRCEA BUSA  BANKA BUSB  BANKB BUSC  BANKC BANKN
BLANK End of output requests.....:
C
C Plot request Data.....
2Capacitor switching problem
C ----Graph type: 4(volts) 8(branch volts) 9(currents)
C ; ----Units: 1(deg) 2(cyc) 3(sec) 4(msec) 5(microsec)
C ;|-----Units per inch
C ;|-----Plot starting time
C ;|-----Plot stopping time
C ;|-----Value at bottom of vertical scale
C ;|-----Value at top of vertical scale
C
C VV<--|<--|<--|<--|<--|Bus-->Bus-->Bus-->Bus-->Heading----->Vert axis----->
  144 5. 0.0 50. -3.0 3.0BUSA  BANKA          CapDeEnerPhA  PU Voltage
  144 5. 0.0 50. -3.0 3.0BUSC  BANKC          CapDeEnerPhC  PU Voltage
  144 5. 0.0 50. -3.0 3.0BUSB  BANKB          CapDeEnerPhB  PU Voltage
BLANK End of Plot Request.....:
BLANK End of All Cases

```

(b) Input data.

Figure 13.1: (continued).

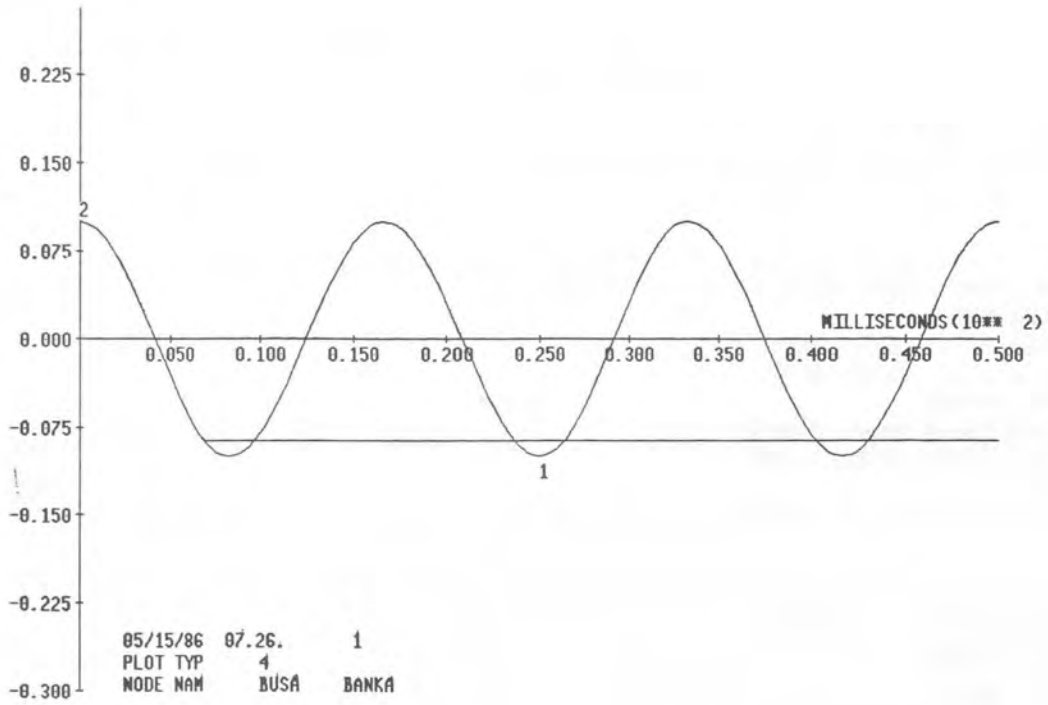

(c) Voltages across phase a.

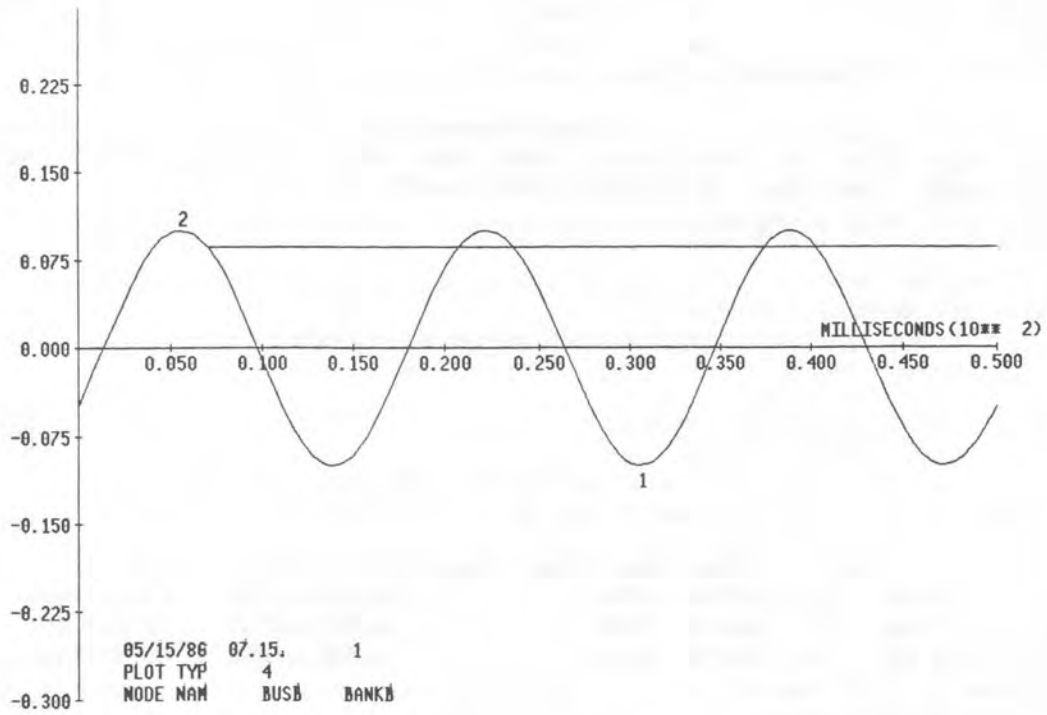

(d) Voltages across phase b.

Figure 13.1: (continued).

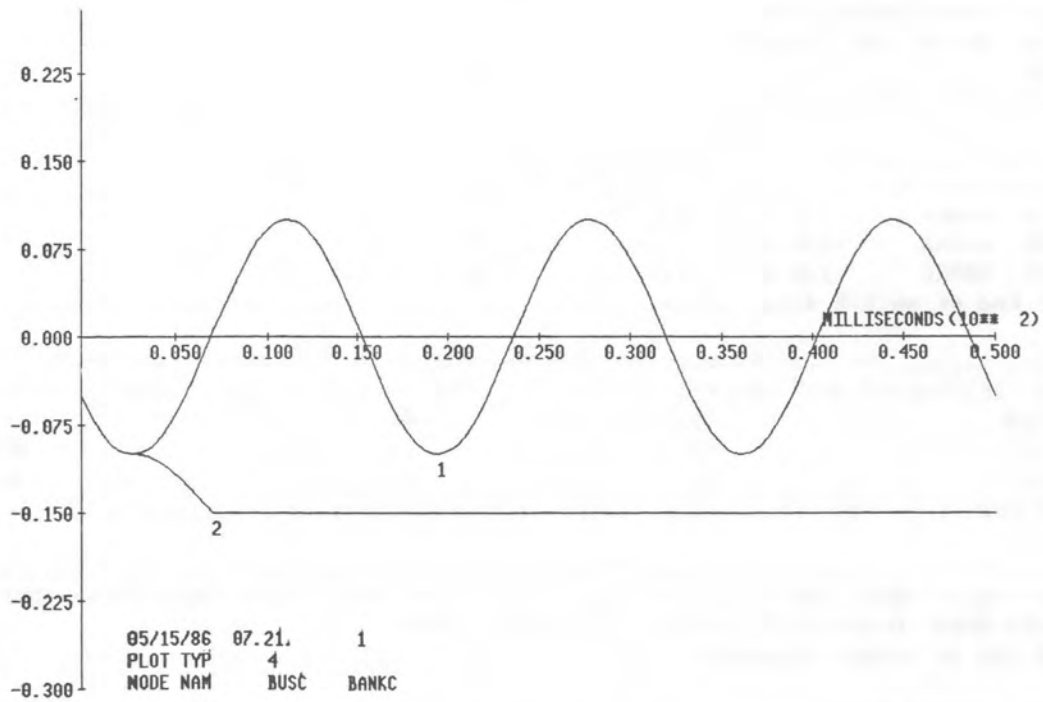

(e) Voltages across phase c..

Figure 13.1: (continued).

```

BEGIN NEW DATA CASE
C -----Figure 13.2(b)-----
C Opening of a breaker in a capacitor bank
C ----dt<---tmax<-Xopt
C 50.E-6 50.E-3 60.
C -Iprnt<---Iplot<-Idoubl<-KssOut<-MaxOut          <---Icat
C      15      1      0      0      0              0
C
C .....Circuit data.....
C Bus-->Bus-->Bus-->Bus--><---R<---L<---C          0
C SRCEA BUSA          .001          0
C SRCEB BUSB SRCEA BUSA          0
C SRCEC BUSC SRCEA BUSA          0
C BANKA BANKN          1000.        2
C BANKB BANKN BANKA BANKN          2
C BANKC BANKN BANKA BANKN          2
C BANKN          .1          0
BLANK End of circuit data.....;
C
C .....Switch data.....
C Bus-->Bus--><---Tclose<---Topen<---Ie          0
C BUSA BANKA -1.E-3 8.E-3 0          2
C BUSB BANKB -1.E-3 8.E-3 0          2
C BUSC BANKC -1.E-3 1.E-3 0          2
BLANK End of switch data.....;
C
C .....Source data.....
C Bus--><I<Amplitude<Frequency<---T0:Phi0<---0=Phi0          <---Tstart<---Tstop
14SRCEA          1. 60. 0. 0.          -1. 9999.
14SRCEB          1. 60. -120. 0.          -1. 9999.
14SRCEC          1. 60. 120. 0.          -1. 9999.
BLANK End of source data.....;
C
C .....Output Request Data.....
C Bus-->Bus-->Bus-->Bus-->Bus-->Bus-->Bus-->Bus-->Bus-->Bus-->Bus-->
SRCEA BUSA BANKA BUSB BANKB BUSC BANKC BANKN
BLANK End of output requests.....;
C
C Plot request Data.....
2Capacitor switching problem, phases B and A stuck
C ----Graph type: 4(volts) 8(branch volts) 9(currents)
C ; ----Units: 1(deg) 2(cyc) 3(sec) 4(msec) 5(microsec)
C ; ----Units per inch
C ; ----Plot starting time
C ; ----Plot stopping time
C ; ----Value at bottom of vertical scale
C ; ----Value at top of vertical scale
C
C VV<---<---<---<---<---Bus-->Bus-->Bus-->Bus-->Heading----->Vert axis----->
144 5. 0.0 50. -3.0 3.0BUSC BANKC CapDeEnerPhC PU Voltage
144 5. 0.0 50. -3.0 3.0BUSB BANKB CapDeEnerPhB PU Voltage
144 5. 0.0 50. -3.0 3.0BUSA BANKA CapDeEnerPhA PU Voltage
BLANK End of Plot Request.....;
BLANK End of All Cases

```

(a) Input data.

Figure 13.2: Same as 13.1, but breakers for phases A and B stuck.

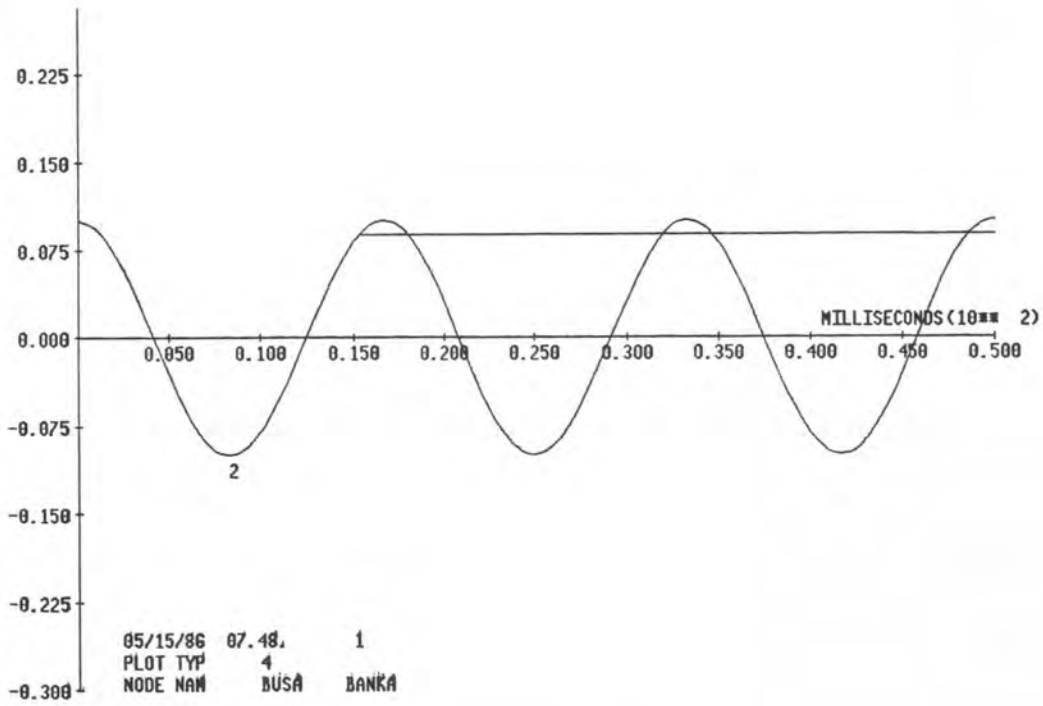

(b) Phase a voltages.

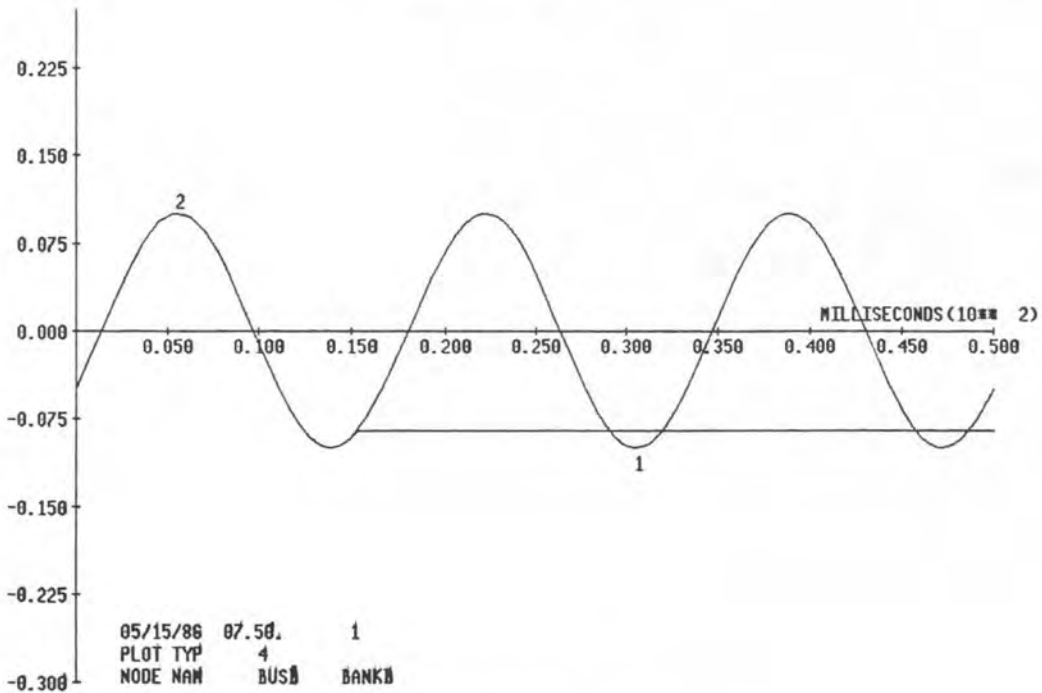

(c) Phase b voltages.

Figure 13.2: (continued).

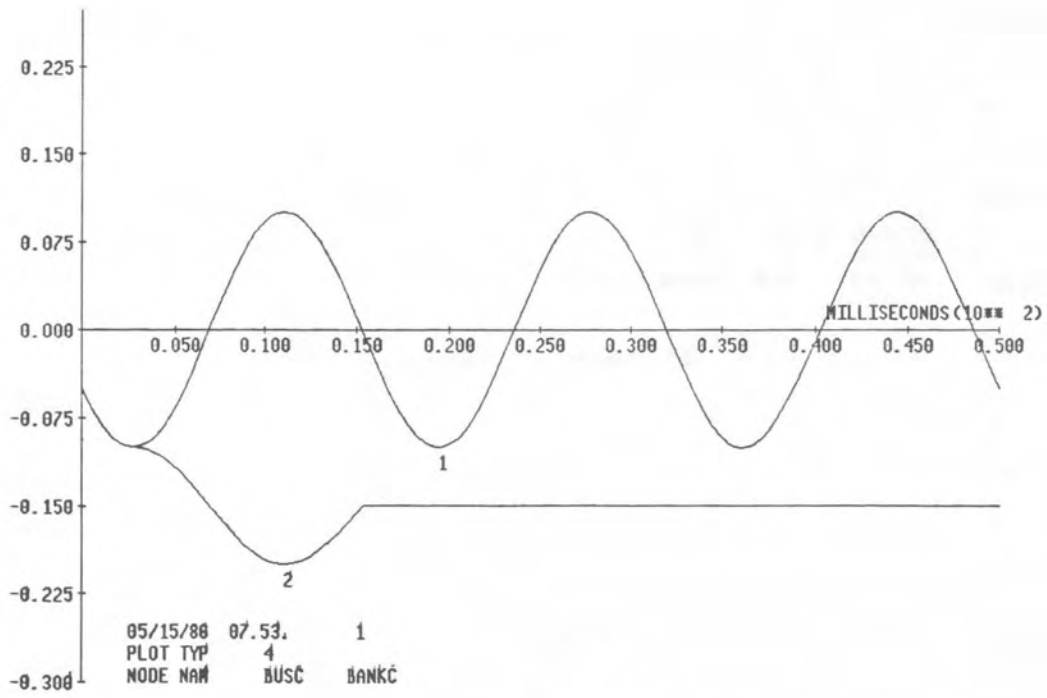

(d) Phase c voltages.

Figure 13.2: (continued).

```

BEGIN NEW DATA CASE
C -----Figure 13.3(b)-----
C Opening of a breaker in a capacitor bank
C ----dt<---tmax<-Xopt
  50.E-6  50.E-3  60.
C -Iprnt<--Iplot<-Idoubl<-KssOut<-MaxOut          <---Icat
   15      1      0      0      0                  0
C
C .....Circuit data.....
C Bus-->Bus-->Bus-->Bus--><---R<---L<---C          0
  SRCEA BUSA                               .001      0
  SRCEB BUSB  SRCEA BUSA                    0          0
  SRCEC BUSC  SRCEA BUSA                    0          0
  BANKA BANKN                               1000.      2
  BANKB BANKN BANKA BANKN                   2          2
  BANKC BANKN BANKA BANKN                   2          2
  BANKN                                       .1          0
BLANK End of circuit data.....!
C
C .....Switch data.....
C Bus-->Bus--><---Tclose<---Topen<---Ie          0
  BUSA  BANKA  -1.E-3  1.E-3  0          2
  BUSB  BANKB  -1.E-3  8.E-3  0          2
  BUSC  BANKC  -1.E-3  1.E-3  0          2
BLANK End of switch data.....!
C
C .....Source data.....
C Bus--><I<Amplitude<Frequency<---T0:Phi0<---O=Phi0  <---Tstart<---Tstop
14SRCEA      1.      60.      0.      0.      -1.      9999.
14SRCEB      1.      60.     -120.     0.      -1.      9999.
14SRCEC      1.      60.     120.      0.      -1.      9999.
BLANK End of source data.....!
C
C .....Output Request Data.....
C Bus-->Bus-->Bus-->Bus-->Bus-->Bus-->Bus-->Bus-->Bus-->Bus-->Bus-->
  SRCEA BUSA  BANKA BUSB  BANKB BUSC  BANKC BANKN
BLANK End of output requests.....!
C
C Plot request Data.....
2Capacitor switching problem, breaker B stuck
C -----Graph type: 4(volts) 8(branch volts) 9(currents)
C ; -----Units: 1(deg) 2(cyc) 3(sec) 4(msec) 5(microsec)
C ; ; -----Units per inch
C ; ; ; -----Plot starting time
C ; ; ; -----Plot stopping time
C ; ; ; -----Value at bottom of vertical scale
C ; ; ; -----Value at top of vertical scale
C ; ; ; ;
C VV<--<--<--<--<--<--Bus-->Bus-->Bus-->Bus-->Heading----->Vert axis----->
  144 5. 0.0 50. -3.0 3.0BUSC  BANKC      CapDeEnerPhC  PU Voltage
  144 5. 0.0 50. -3.0 3.0BUSB  BANKB      CapDeEnerPhB  PU Voltage
  144 5. 0.0 50. -3.0 3.0BUSA  BANKA      CapDeEnerPhA  PU Voltage
BLANK End of Plot Request.....!
BLANK End of All Cases

```

(a) Input data.

Figure 13.3: Same as 13.1, but breaker for phase B stuck. Notice pu TRV in excess of 3 pu on phase C.

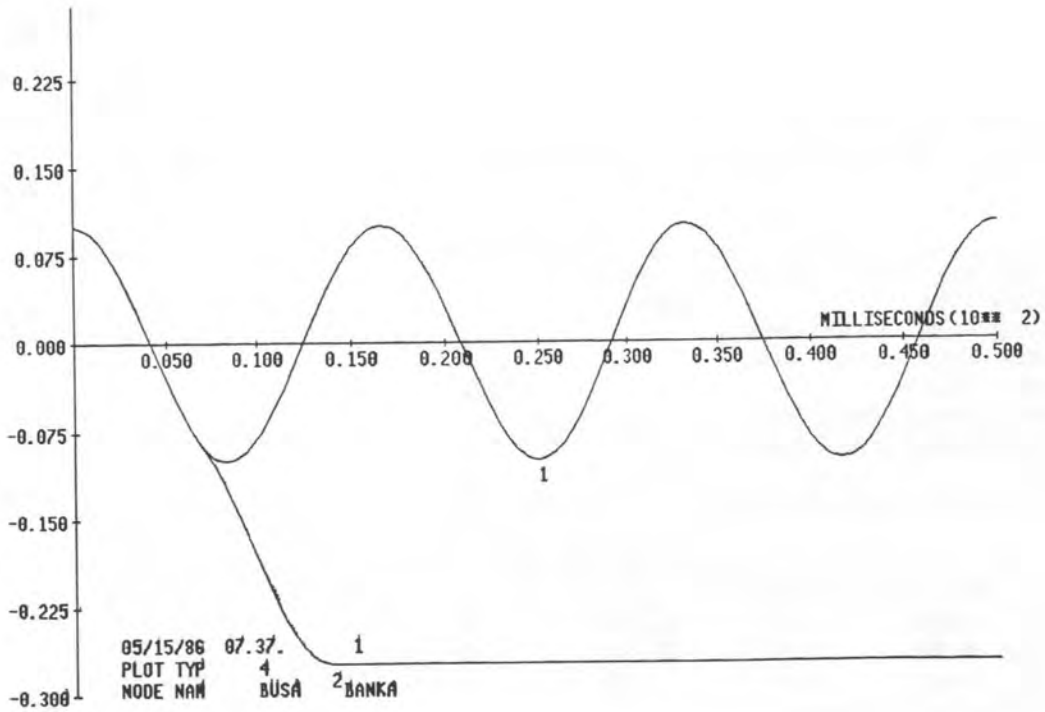

(b) Phase a voltage.

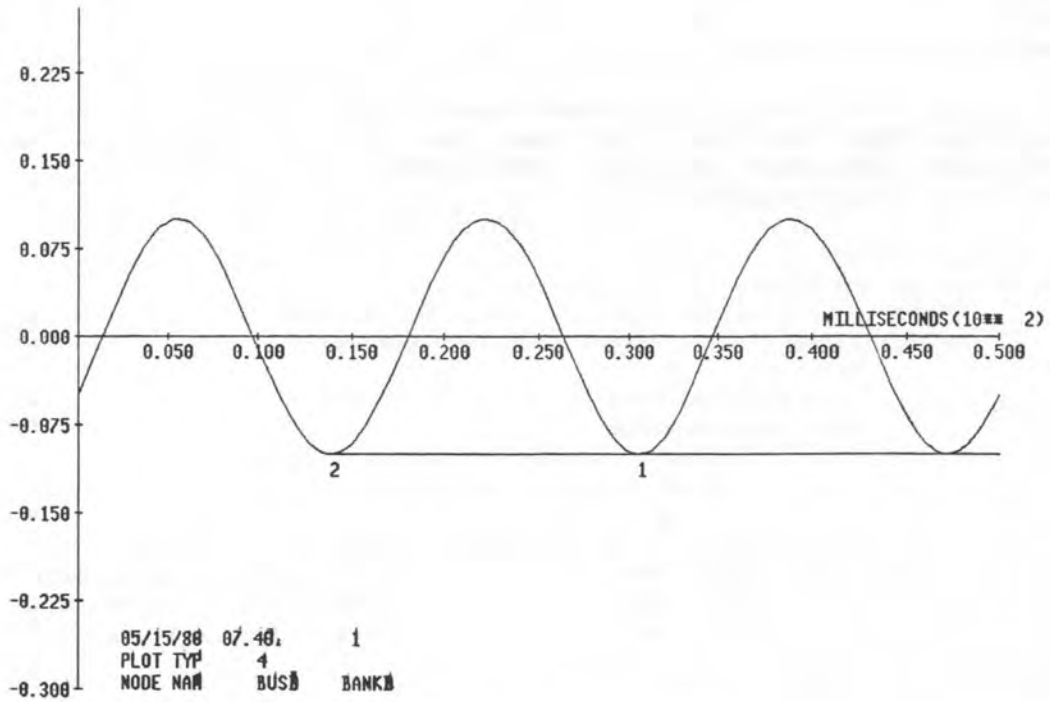

(c) Phase b voltage.

Figure 13.3: (continued).

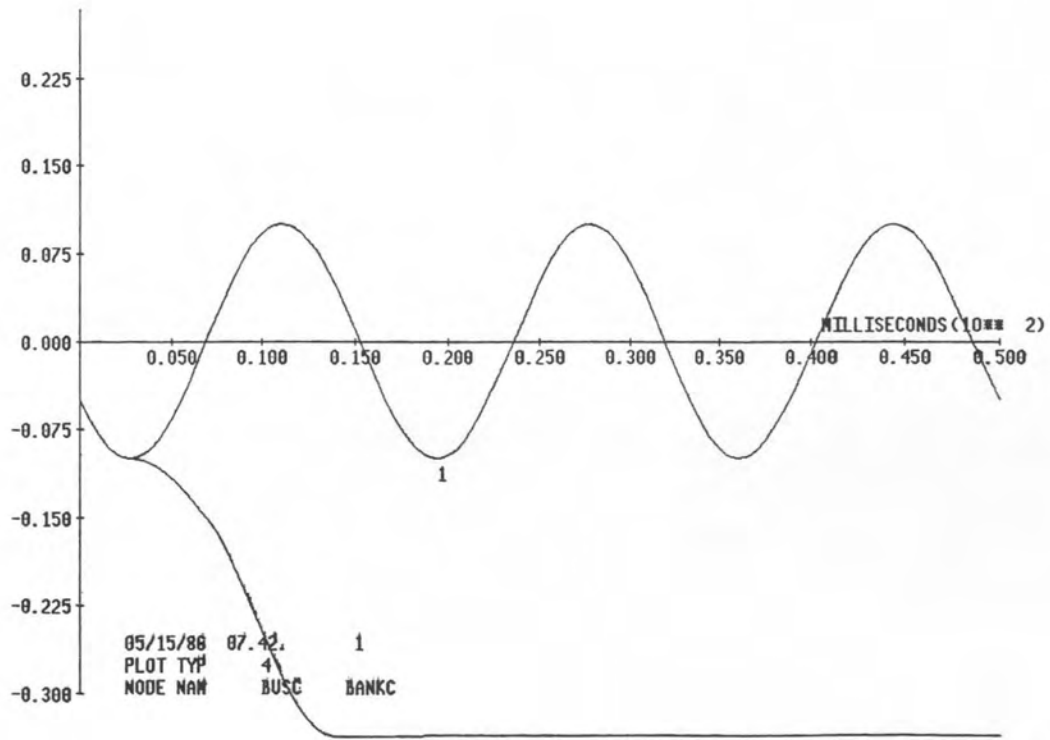

(d) Phase c voltage.

Figure 13.3: (continued).

Section 14

REPRESENTATION OF LIGHTNING ARRESTERS AND OTHER NONLINEARITIES

It is of some interest to learn how the EMTP represents nonlinearities and time-dependent devices (Figure 14.1). The two examples of greatest interest are lightning arresters and transformer saturation. In these cases the EMTP constructs a Thevenin network as seen from the terminals of the nonlinear device (Figure 14.2). This gives a single linear equation on two variables: $(e_k - e_m)$ and i_{km} . The nonlinearity itself provides the other equation. A simultaneous iterative solution of these two equations gives the conditions at the nonlinear element.

One minor observation about this process is that it is possible that in some cases no solution may exist to the problem. This usually indicates an inadequate model. In other cases there may be more than one solution. The EMTP will "track" one of these, but that may not be the correct physical solution (Figure 14.3). Initial conditions become very important.

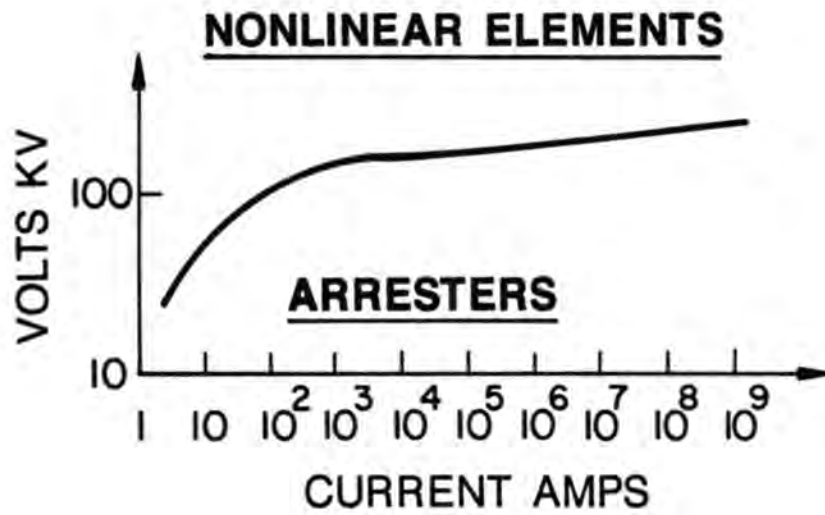

(a) Ordinary nonlinearity.

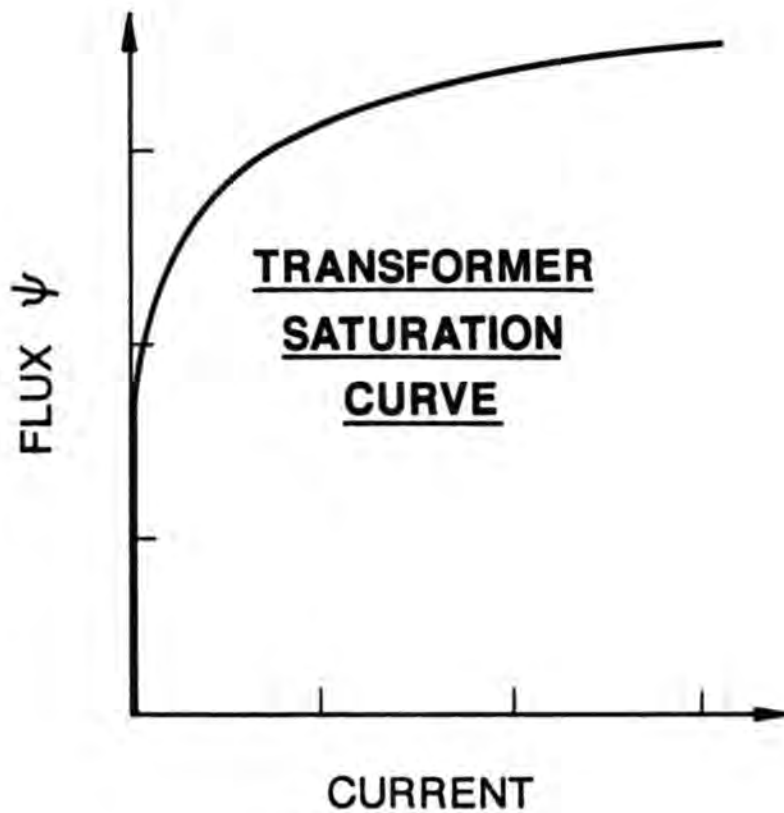

(b) Nonlinear inductance.

Figure 14.1: The variable characteristic devices handled by the EMTP.

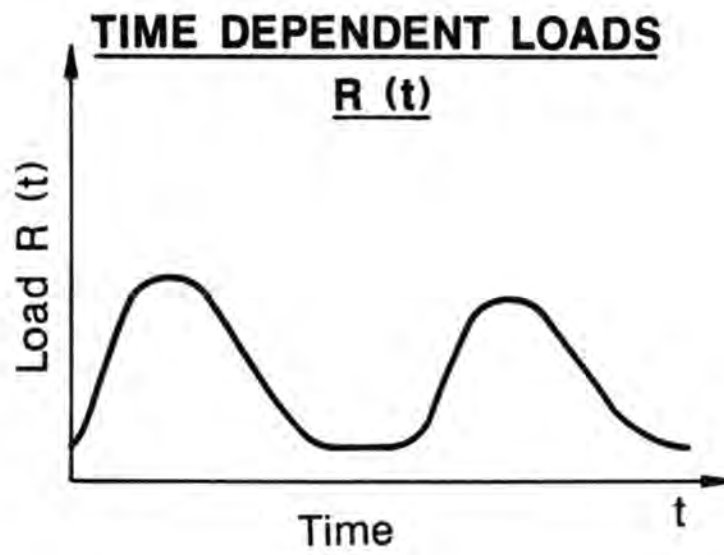

(c) Time-dependent resistance.

Figure 14.1: (continued).

EMTP NONLINEAR METHODS

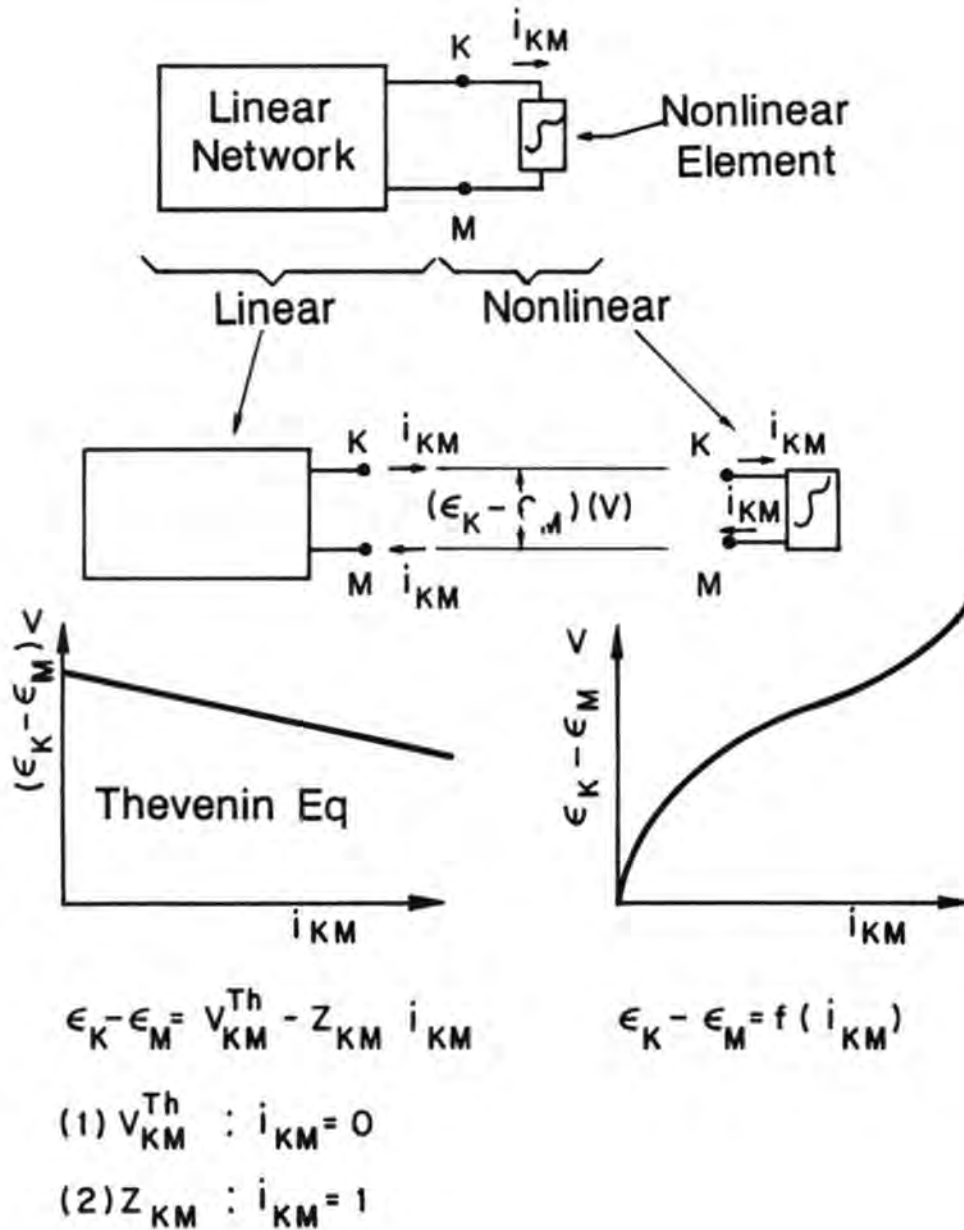
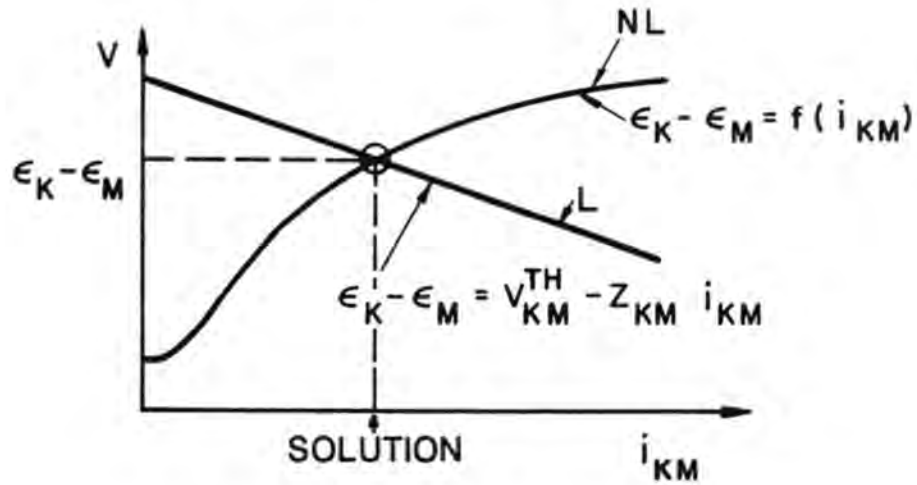

Figure 14-2. How the EMTP represents nonlinearities.

EMTP SOLUTION



SOLVING TWO
SIMULTANEOUS EQUATIONS
FOR
 $\epsilon_K(t) - \epsilon_M(t)$ and $i_{KM}(t)$

PROBLEMS

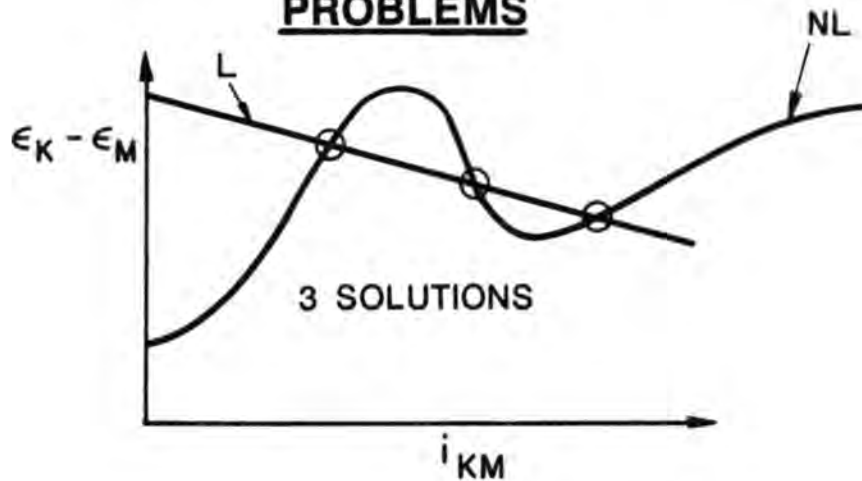

Figure 14.3: Nonlinearities may lead to multiple solutions.

Time-dependent loads are handled the same way, except that in this case both equations are linear, no iterations are required and no multiple solutions may exist. (Figure 14.4).

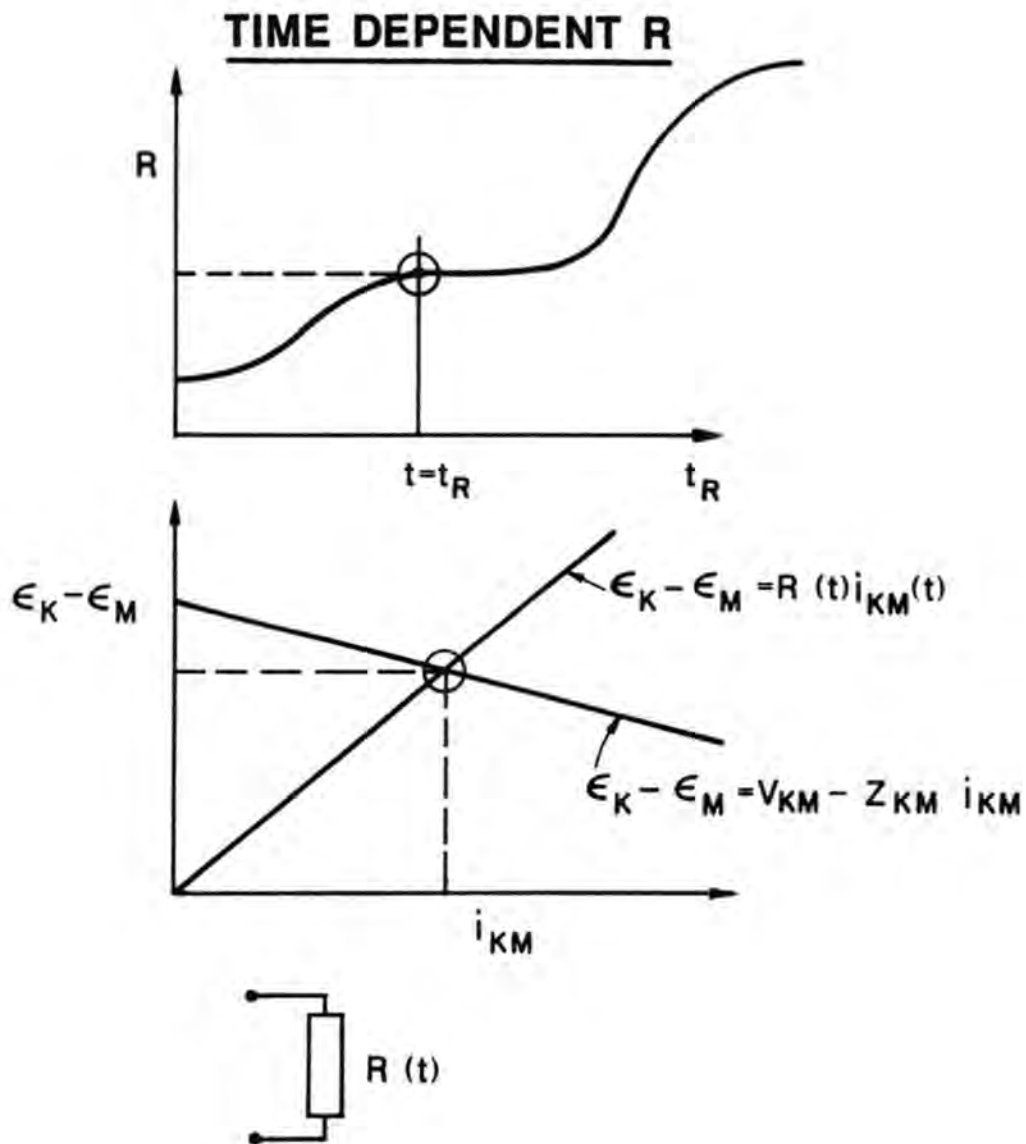
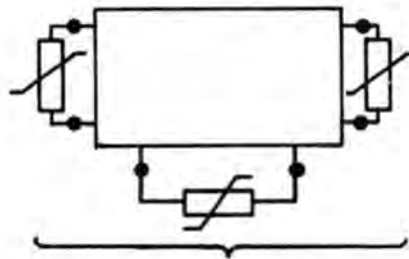

Figure 14.4: Time-dependent resistances.

A direct consequence of the manner in which the EMTP handles nonlinearities is that you may only have one nonlinearity per subnetwork (Note: some capability for 3 phase nonlinearities now exists for ZnO arresters). There are two ways of breaking up an otherwise connected network into subnetworks (Figure 14.5 and 14.6): by using ideal sources or by using distributed lines. A distributed line uses past history information from the other end of the line. During any one time step, whatever happens at one end of the line is not influenced by current events at the other end.

2 OR MORE NONLINEAR ELEMENTS

~3 ARRESTERS



CAN NOT MAKE A SIMPLE
THEVENIN EQUIVALENT

ITERATIVE SOLUTION IS REQUIRED

→
→
→ EMTP: ONE N.L.ELEMENT
PER NETWORK

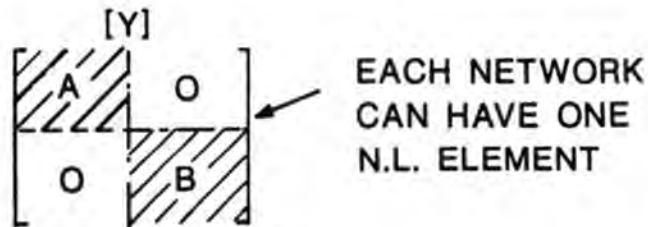

Figure 14.5: Two or more linearities cannot be solved by the EMTP unless they are in different subnetworks.

TYPES OF SUBNETWORKS

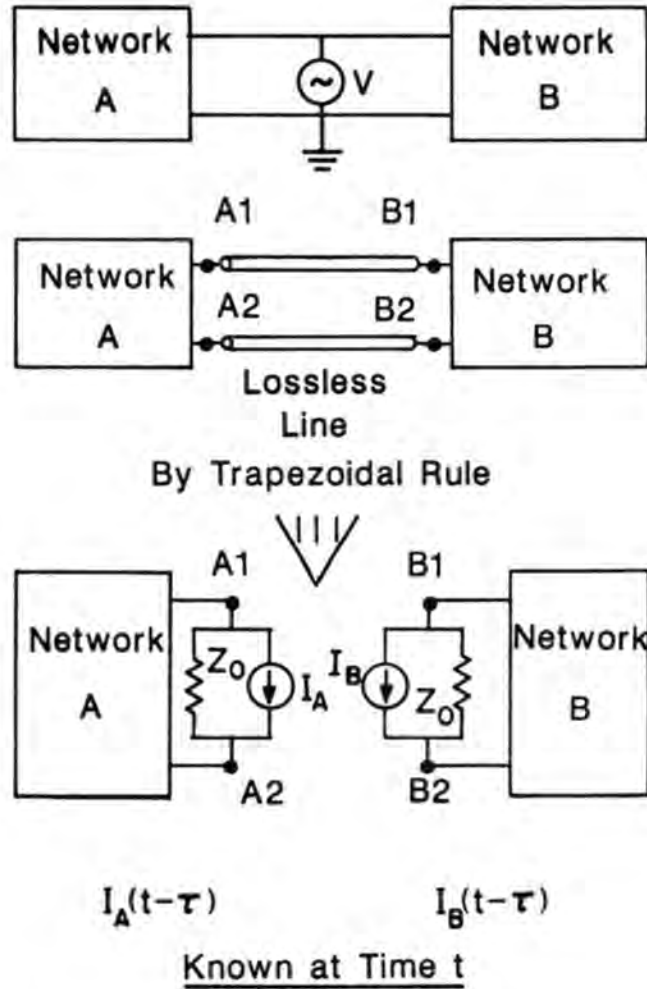

Figure 14.6: How to separate nonlinearities.

The consequence of all this is that users must be careful not to use more than one nonlinearity at the time in a given subnetwork. If this is not possible, a user must:

- Introduce some artificial short (at least $1 \Delta t$) lines to separate nonlinearities.
- Use EMTP "pseudo-nonlinear" elements. These are elements where a one time step delay is introduced. They are less accurate and less reliable, but do not require separation.

Finally, representing nonlinear inductances is done by first reducing the nonlinear inductance to a nonlinear resistance. Figure 14.7 illustrates the reduction process.

The discussion now centers around the practical issues of representing lightning arresters on the EMTP. There are two fundamental ways:

- Use of point-by-point nonlinearities.
- Use of the built-in ZnO arrester model.

Point by point nonlinearities are specified by selecting either a type 92 (true nonlinearity) or a type 99 (a pseudo-nonlinearity). You need at least the following information:

- The fixed series minimum resistance value of the branch.
- The flashover voltage.
- The set of v-i points describing the characteristics of the device. Symmetry around the origin is not assumed.

This device goes into conduction when $v > V_{flash}$, stops conduction when the current crosses zero.

NONLINEAR INDUCTANCE

$$\text{FLUX } \psi(t) = f(i_{KM}(t))$$

$$\psi(t) = \int_0^t (e_K(t) - e_M(t)) dt + \psi(0)$$

By Trapezoidal Rule

$$\psi(t) = \int_{t-\Delta t}^t (e_K - e_M(t)) dt + \int_0^{t-\Delta t} (\epsilon_K - \epsilon_M) dt + \psi(0)$$

OR

$$\psi(t) = \frac{\Delta t}{2} [\epsilon_K(t) - \epsilon_M(t)] + \underbrace{\frac{\Delta t}{2} C (t-\Delta t)}_{\substack{\text{History} \\ \text{Term}}}$$

$$\psi(t) = f(i_{KM})$$

$$(1) \quad \boxed{\epsilon_K(t) - \epsilon_M(t) = \frac{2}{\Delta t} f(i_{KM}) - C (t-\Delta t)}$$

$$(2) \quad \epsilon_K(t) - \epsilon_M(t) = V_{KM}^{Th} - Z_{KM} i_{KM}$$

Figure 14.7: Reducing a nonlinear inductance to a nonlinear resistance.

Point by point nonlinearities are easy to use but should be used with care, since they do not necessarily reproduce accurately the true behavior of gapped arresters.

The other way to represent lightning arresters is using a built-in model of a ZnO arrester. The built-in model uses the following equation:

$$i = p \left(\frac{V}{V_{ref}} \right)^q$$

For the sake of efficiency, the EMTP uses a very large resistance until V exceed some V_{min} fractions of its nominal voltage.

To use this model you need to know:

- The nominal voltage V_{ref} .
- The exponent q .
- The coefficient p .

Figure 14.8 illustrates a simple 200 mile line terminated by a ZnO arrester with:

$$p = 2500$$

$$q = 26$$

$$V_{ref} = 778 \text{ kV}$$

$$V_{min} = .5$$

The enclosed coding sheets give details on the formats for both kinds of ways of representing lightning arresters.

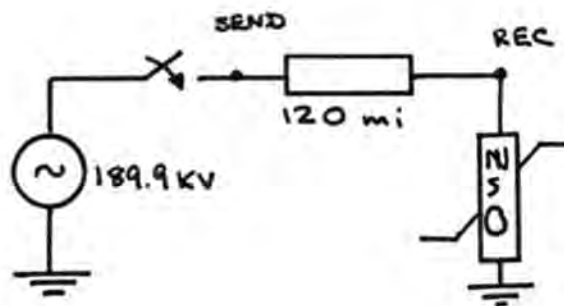

(a) Circuit diagram.

Figure 14.8: Energization of line 1-2 from ideal source. Line terminated in ZnO arrester.

```

BEGIN NEW DATA CASE
C -----Figure 14.8-----
C Model of a pure single phase ZnO gapless arrester at the end of 120mi Line
C .....
C
C ----dt<---tmax
50.E-6 20.E-3
C
C -lprnt<---lplot<-----Ignore-----><---lcat<---Ignore----->
15 1 0
C
C .....Circuit data.....
C Bus-->Bus-->Bus-->Bus--><---R<---L<---C<-----Ignore for now----->0
SEND 1. 0
C Bus-->Bus-->Bus-->Bus--><---R'<---L'<---C'<---len 0 0 0 0
-ISEND REC 0.3167 3.222.00787 193.1 0 0 0
C Bus-->Bus--><-----ZnO model-----> 5555.<-----Ignore for now----->0
92REC 5555. 1
C -----VREF<-----Vflash<-----Vzero
206600. 0. 0.
C -----p<-----q<-----Vmin
1500. 26. .5
9999.
BLANK End of circuit data.....:
C
C .....Switch data.....
C Bus-->Bus--><---Tclose<---Topen<-----Ignore for now----->0
BLANK End of switch data.....:
C
C .....Source data.....
C Bus--><I<Amplitude<Frequency<---T0<Phi0<---0=Phi0 <---Tstart<---Tstop
14SEND 187790. 60. 0 0. 0. 9999.
BLANK End of source data.....:
C
C .....Output Request Data.....
C Bus-->Bus-->Bus-->Bus-->Bus-->Bus-->Bus-->Bus-->Bus-->Bus-->Bus-->
SEND REC
BLANK End of output requests.....:
C
C Plot request Data.....
C Graph type: 4(volts) 8(branch volts) 9(currents)
C ; Units: 1(deg) 2(cyc) 3(sec) 4(msec) 5(microsec)
C ; Units per inch
C ; Plot starting time
C ; Plot stopping time
C ;
C VV<---I<---I<--- Bus-->Bus-->Bus-->Bus-->Heading----->Vert axis----->
144 2. 0.0 20. SEND REC ZnOArrester REC KV
194 2. 0.0 20. REC ZnOArrester ArrCurr
BLANK End of Plot Request.....:
BLANK End of All Cases

```

(b) Input data.

Figure 14.8: (continued).

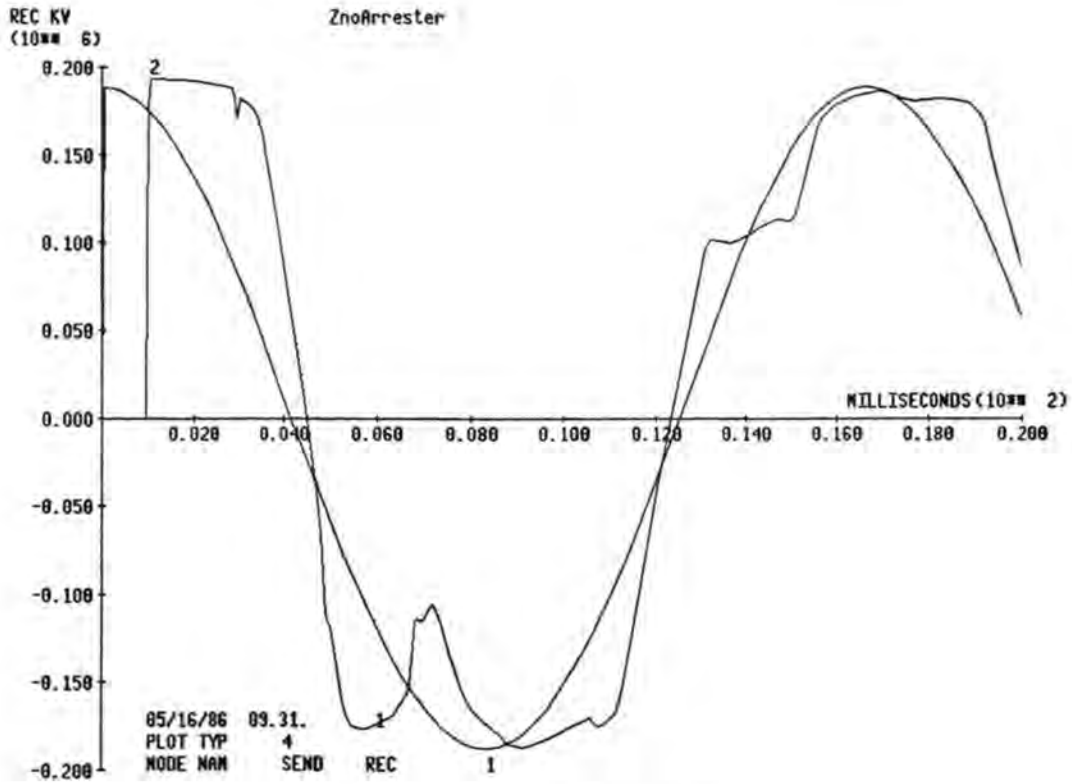

(c) Arrester voltage.

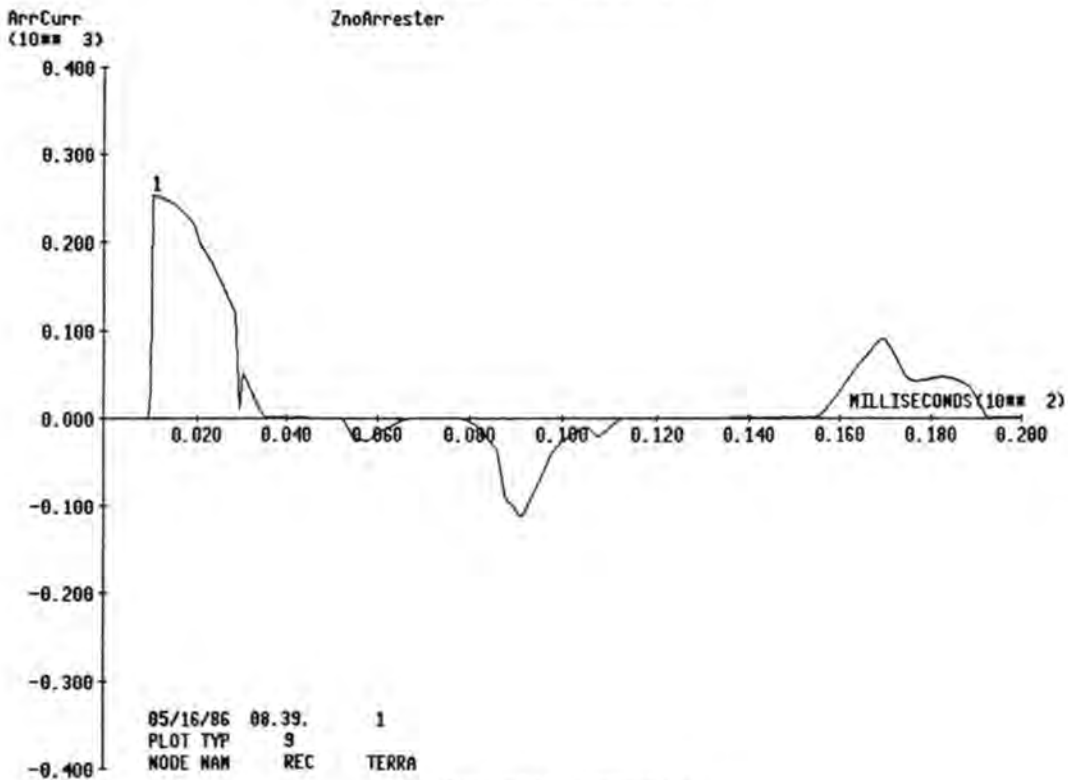

(d) Arrester current.

Figure 14.8: (continued).

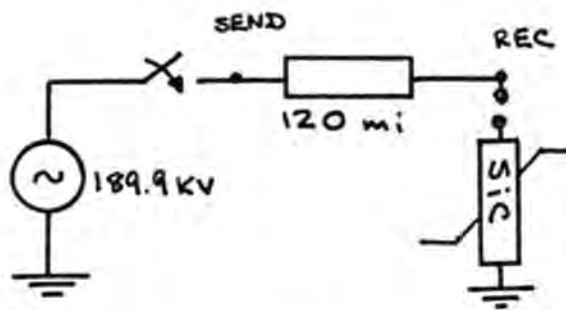

(a) Circuit diagram.

Figure 14.9: Energization of same line, but terminated in a SiC gapped arrester.

```

BEGIN NEW DATA CASE
C -----Figure 14.9-----
C Model of a Gapped SiC arrester at the end of line 1-2 using exact nonlin :
C .....
C ----dt<---tmax
  50.E-6 20.E-3
C
C -lprnt<---lplot<-----ignore-----><---Icat<---ignore----->
   15      1                                     0
C .....Circuit data.....
C Bus-->Bus-->Bus-->Bus--><---R<---L<---C<---ignore for now----->0
  SEND                                     1.                                     0
C Bus-->Bus-->Bus-->Bus--><---R'<---L'<---C'<---len 0 0 0
-1SEND REC                                0.3167 3.222.00787 193.1 0 0 0
C True Multi-phase Gapped Nonlinearity Model
C                                     -1: gap flashes, stays closed
C                                     :_0: gap flashes on and off
C                                     :_1: gap flashes, clears once
C Bus-->Bus-->Bus-->Bus--><---;      4444.<-Code in Col 40-44
92REC                                     4444.
C -----Rlin<-----Vflash<-----Vzero
   0.                                     234740.
C -----Current<-----Voltage
   16.1                                  150000.
   94.5                                  200000.
   167.3                                  220000.
   282.1                                  240000.
   455.0                                  260000.
   711.2                                  280000.
   1076.0                                  300000.
   6046.6                                  400000.
   9999.
BLANK End of circuit data.....
C .....Switch data.....
C Bus-->Bus--><---Tclose<---Topen<-----ignore for now----->0
BLANK End of switch data.....
C .....Source data.....
C Bus--><I<Amplitude<Frequency<---T0;Phi0<---0=Phi0 <---tstart<---Tstop
14SEND 187790. 60. 0 0. 0. 0. 9999.
BLANK End of source data.....
C .....Output Request Data.....
C Bus-->Bus-->Bus-->Bus-->Bus-->Bus-->Bus-->Bus-->Bus-->Bus-->Bus-->
  SEND REC
BLANK End of output requests.....
C Plot request Data.....
C -----Graph type: 4(volts) 8(branch volts) 9(currents)
C :_Units: 1(deg) 2(cyc) 3(sec) 4(msec) 5(microsec)
C :_Units per inch
C :_Plot starting time
C :_Plot stopping time
C :_
C VV<--<--<--<--< Bus-->Bus-->Bus-->Bus-->Heading----->Vert axis----->
  144 2. 0.0 20. SEND REC Gap SiC arresterREC Volts

```

(b) Input data.

Figure 14.9: (continued).

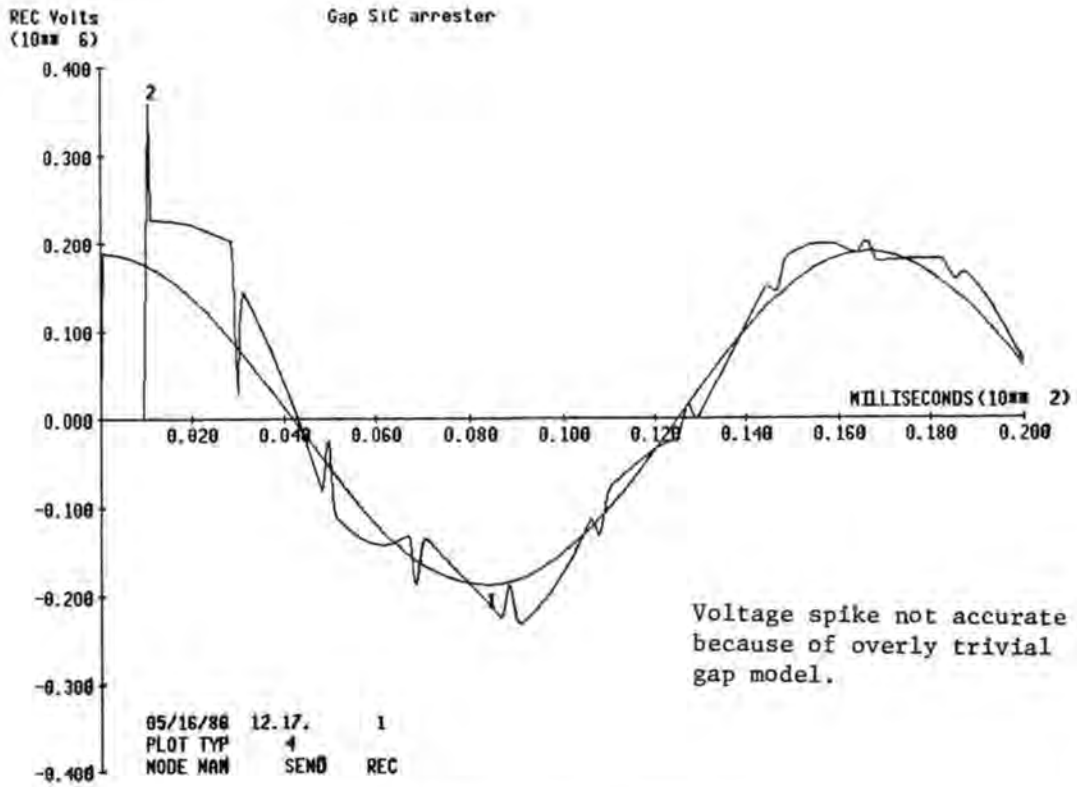

(c) Voltage across arrester.

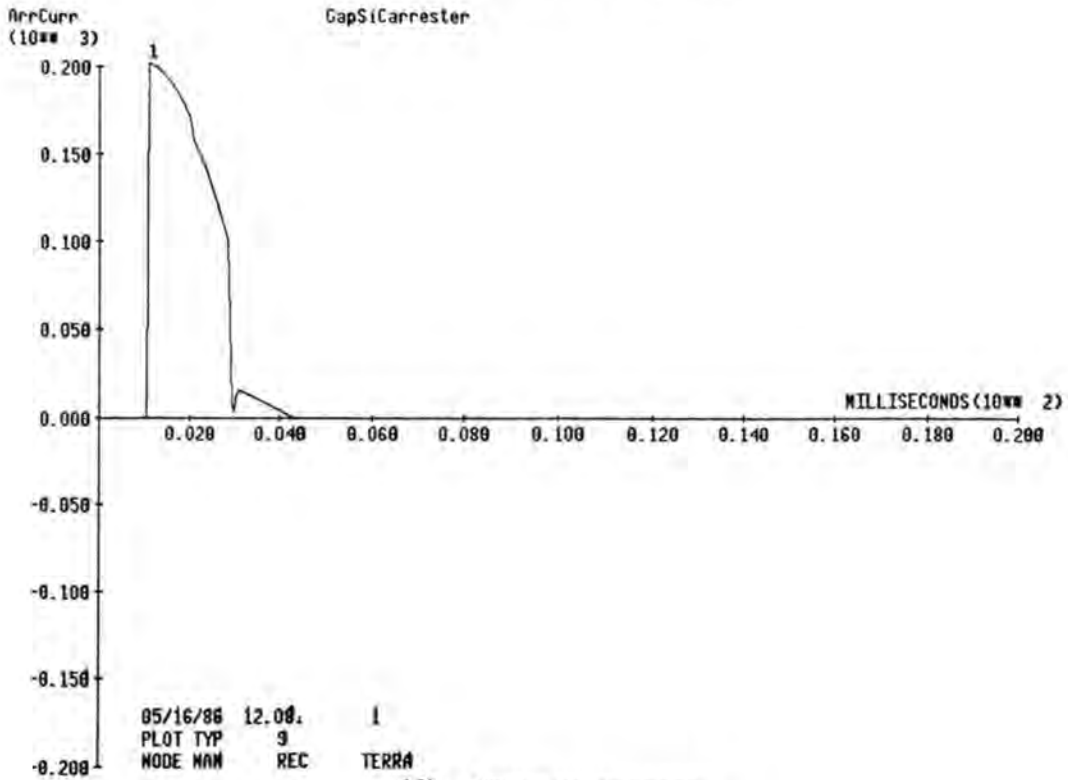

(d) Arrester current.

Figure 14.9: (continued).

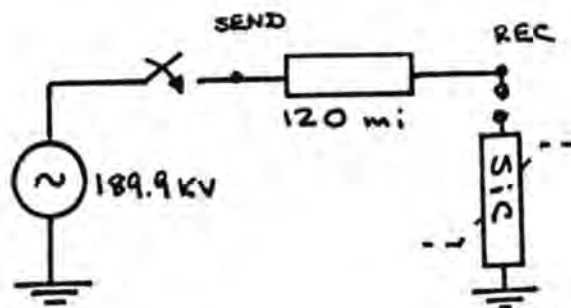

(a) Circuit diagram.

Figure 14.10: Same as 14.9, but using the pseudo-nonlinear arrester model.

```

BEGIN NEW DATA CASE
C -----Figure 14.10-----
C Model of a gapped SiC arrester at end of 120Mi line using pseudo-nonlin model.
C .....
C
C ----dt<---tmax
C 50.E-6 20.E-3
C
C -Iprnt<--Iplot<-----Ignore-----><---Icat<---Ignore----->
C      15      1                                0
C
C .....Circuit data.....
C Bus-->Bus-->Bus-->Bus--><---R<---L<---C<---Ignore for now----->0
C SEND 1. 0
C Bus-->Bus-->Bus-->Bus--><---R'<---L'<---C'<---len 0 0 0 0
C -1SEND REC 0.3167 3.222.00787 193.1 0 0 0
C Pseudo Nonlinear Resistance Model
C
C Bus-->Bus-->Bus-->Bus--><Vflsh<ldely<Jump<Vseal 0
C 99REC 235.E3 1
C -----Current<-----Voltage
C      16.1      150000.
C      94.5      200000.
C      167.3     220000.
C      282.1     240000.
C      455.0     260000.
C      711.2     280000.
C      1076.0    300000.
C      6046.6    400000.
C      9999.
BLANK End of circuit data.....;
C
C .....Switch data.....
C Bus-->Bus--><---Tclose<---Topen<-----Ignore for now----->0
BLANK End of switch data.....;
C
C .....Source data.....
C Bus--><I<Amplitude<Frequency<---T0<Phi0<---0=Phi0 <---Tstart<---Tstop
C 14SEND 187790. 60. 0 0. 0. 0. 9999.
BLANK End of source data.....;
C
C .....Output Request Data.....
C Bus-->Bus-->Bus-->Bus-->Bus-->Bus-->Bus-->Bus-->Bus-->Bus-->Bus-->
C SEND REC
BLANK End of output requests.....;
C
C Plot request Data.....
C _____Graph type: 4(volts) 8(branch volts) 9(currents)
C : _____Units: 1(deg) 2(cyc) 3(sec) 4(msec) 5(microsec)
C :: _____Units per inch
C :: | _____Plot starting time
C :: | _____Plot stopping time
C :: |
C VV<--<--<--< Bus-->Bus-->Bus-->Bus-->Heading----->Vert axis----->
C 194 2. 0.0 20. REC Gap SiC arr ps ArrCurr
C 144 2. 0.0 20. SEND REC Gap SiC arr ps REC Volts
BLANK End of Plot Request.....;
BLANK End of All Cases

```

(b) Input data.

Figure 14.10: (continued).

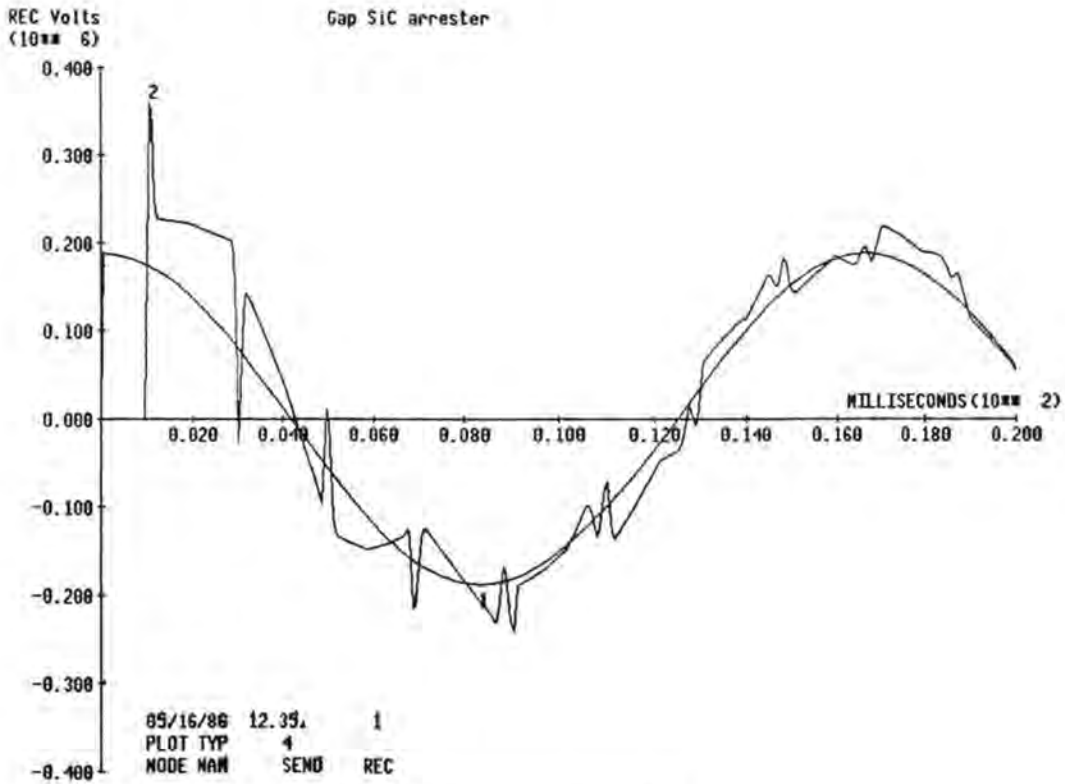

(c) Arrester voltage.

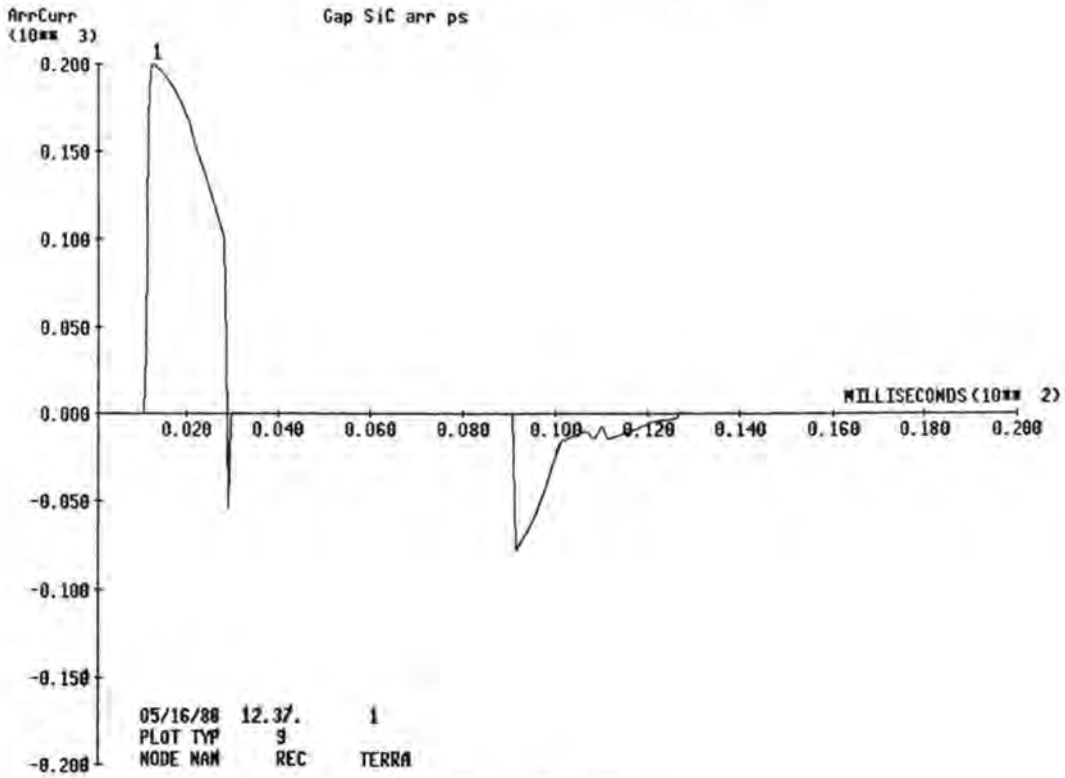

(d) Arrester current.

Figure 14.10: (continued).

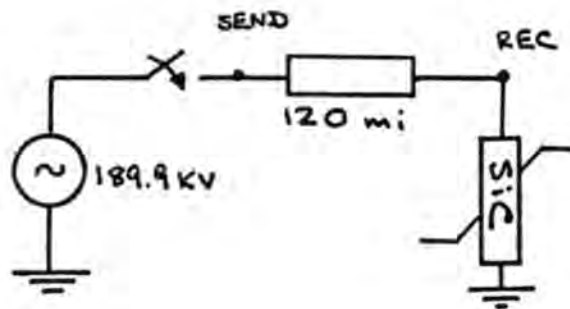

(a) Circuit diagram.

Figure 14.11: Same, with gapless SiC arresters.

```

BEGIN NEW DATA CASE
C -----Figure 14.11-----
C Model of a Gappless SiC arrester at the end of line 1-2 using exact nonlin  !
C .....
C
C ----dt<---tmax
C 50.E-6 20.E-3
C
C -lprnt<---lplot<-----ignore----->---lcat<---ignore----->
C 15 1 0
C .....Circuit data.....
C Bus-->Bus-->Bus-->Bus--><---R<---L<---C<---ignore for now----->0
SEND 1. 0
C Bus-->Bus-->Bus-->Bus--><---R'<---L'<---C'<---len 0 0 0 0
-1SEND REC 0.3167 3.222.00787 193.1 0 0 0 0
C True Multi-phase Gapped Nonlinearity Model
C _-1: gap flashes, stays closed
C _-0: gap flashes on and off
C _-1: gap flashes, clears once
C Bus-->Bus-->Bus-->Bus--><---: 4444.<---Code in Col 40-44 0
92REC 4444. 1
C -----Rlin<-----Vflash<-----Vzero
C 0. -1. 0.
C -----Current<-----Voltage
C 16.1 150000.
C 94.5 200000.
C 167.3 220000.
C 282.1 240000.
C 455.0 260000.
C 711.2 280000.
C 1076.0 300000.
C 6046.6 400000.
C 9999.
BLANK End of circuit data.....!
C .....Switch data.....
C Bus-->Bus--><---Tclose<---Topen<-----ignore for now----->0
BLANK End of switch data.....!
C .....Source data.....
C Bus--><I<Amplitude<Frequency<---T0:Phi0<---0=Phi0 <---Tstart<---Tstop
14SEND 187790. 60. 0 0. 0. 0. 9999.
BLANK End of source data.....!
C .....Output Request Data.....
C Bus-->Bus-->Bus-->Bus-->Bus-->Bus-->Bus-->Bus-->Bus-->Bus-->
SEND REC
BLANK End of output requests.....!
C Plot request Data.....
C _-Graph type: 4(volts) 8(branch volts) 9(currents)
C _-Units: 1(deg) 2(cyc) 3(sec) 4(msec) 5(microsec)
C _-Units per inch
C _-Plot starting time
C _-Plot stopping time
C _-Value at bottom of vertical scale
C _-Value at top of vertical scale
C VV<---<---<---<---<---:Bus-->Bus-->Bus-->Bus-->Heading----->Vert axis----->

```

(b) Input data.

Figure 14.11: (continued).

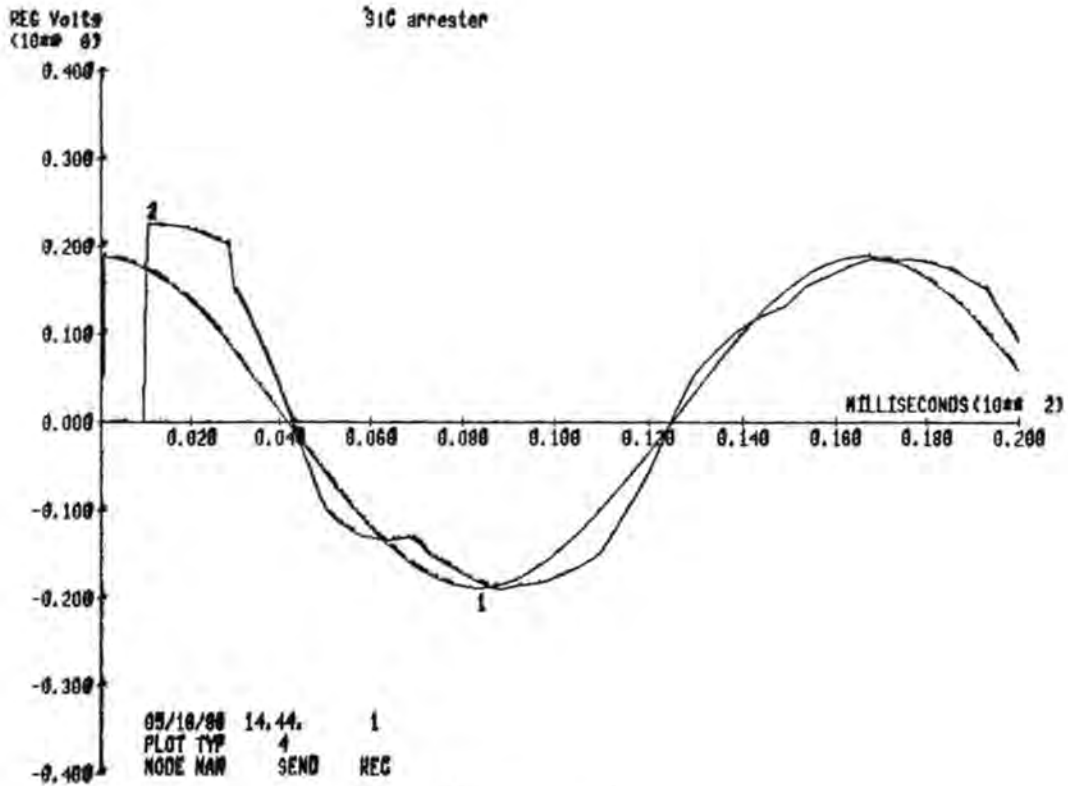

(c) Arrester voltage.

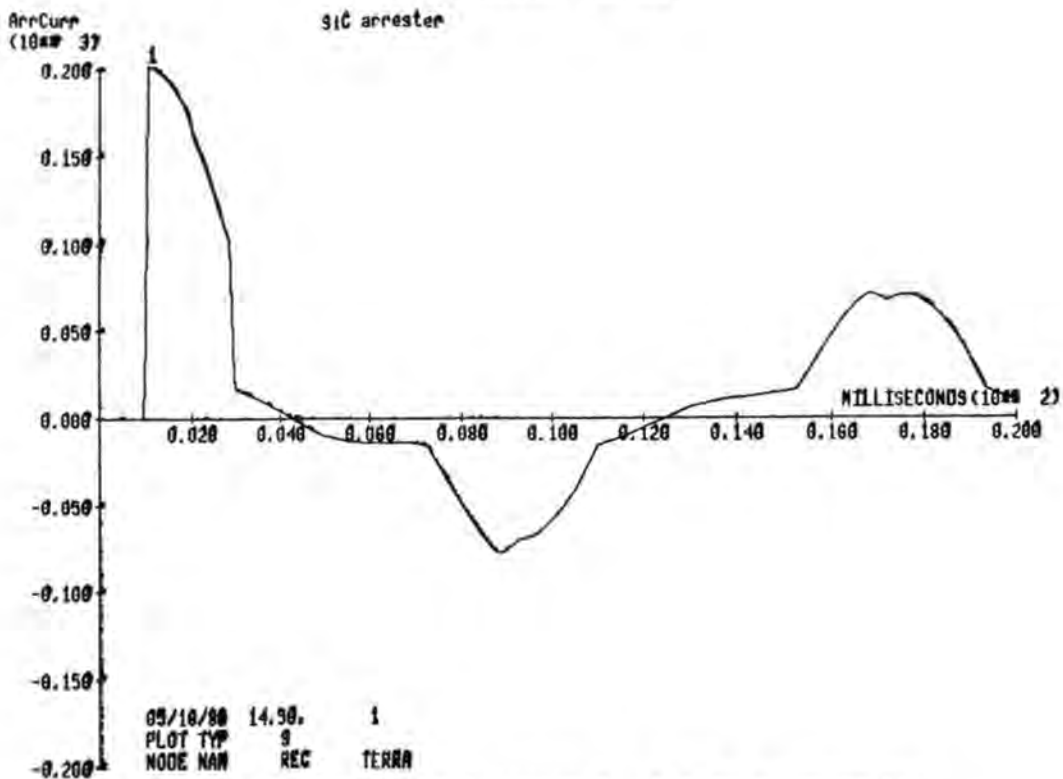

(d) Current through arrester. Notice unacceptably large current during normal operation.

Figure 14.11: (continued).

Problem 14.1: Prepare the data for a more comprehensive case where you energize all three phases of line 1-2, use a better model for the systems, and you use ZnO arresters in all three phases. Determine the energy dissipated in each arrester.

Problem 14.2: Using the methods outlined in a paper by a recent IEEE Working Group (*), describe how you could use the EMTP to determine the outage rate of line 1-2.

(*) Working Group on Lightning Performance of Transmission Lines, "A Simplified Method for Estimating Lightning Performance of Transmission Lines", IEEE Transactions on Power Apparatus and Systems, Vol PAS-104, April 1985, pp. 919-927.

```

C
C Zinc Oxide Nonlinearity Model =====
C
C Bus-->Bus-->Bus-->Bus-->          5555.<-Code in Col 40-44          0
92                                     5555.
C .....^.....^.....^.....^          ^^^^^^          ^
C
C -----Vref<-----Vflash<-----Vzero
C .....^.....^.....^.....^.....^
C
C -----Coef<-----Expon<-----Vmin
C .....^.....^.....^.....^.....^
C
C Termination Code
C           9999.
C

```



```

C
C True Multi-phase Gapped Nonlinearity Model =====
C                                     -1: gap flashes, stays closed
C                                     0: gap flashes on and off
C                                     1: gap flashes, clears once
C Bus-->Bus-->Bus-->Bus--><-----| 4444.<-Code in Col 40-44      0
92                                     4444.
C .....^.....^.....^.....^.....^      ^
C
C -----Rlin<-----Vflash<-----Vzero
C .....^.....^.....^.....^.....^
C
C -----Current<-----Voltage
C .....^.....^.....^.....^.....^
C .....^.....^.....^.....^.....^
C .....^.....^.....^.....^.....^
C .....^.....^.....^.....^.....^
C .....^.....^.....^.....^.....^
C .....^.....^.....^.....^.....^
C .....^.....^.....^.....^.....^
C .....^.....^.....^.....^.....^
C .....^.....^.....^.....^.....^
C .....^.....^.....^.....^.....^
C .....^.....^.....^.....^.....^
C
C Termination Code
C          9999.
C

```

Section 15

REPRESENTATION OF TRANSFORMERS

Models for transformers

Representation of transformers for transient studies depend on the intended nature of the study. For slower switching type transients a conventional transformer model such as shown in Figure 1a can be used. For faster transients, brushing and winding capacitances may have to be included and may in fact dominate this behavior. Only models for slower transients, are considered here.

A major issue in the representation of the magnetization branch. We describe this issue in a separate sub section.

Consider a two winding single phase transformer with a voltage rating $KV_1:KV_2$, a power rating MVA, and a leakage impedance of $X\%$. We first can calculate:

$$X_{pu} = \frac{X\%}{100}$$

This reactance must somehow be divided among both windings. This is not a simple issue, and it gets more complicated for three winding transformers. However, it can be assumed for simplicity that on a pu basis, the impedance is split evenly among the windings. Then:

$$X_{pu\ 1} = X_{pu} \times .5$$

$$X_{pu\ 2} = X_{pu} \times .5$$

The actual ohmic values for these impedances are:

$$X_{\Omega 1} = X_{pu\ 1} \times Z_{b1}$$

$$X_{\Omega 2} = X_{pu 2} \times Z_{b2}$$

where

$$Z_{b1} = \frac{(KV_1)^2}{MVA} \quad Z_{b2} = \frac{(KV_2)^2}{MVA}$$

Finally, the impedance values should be converted to RL values.

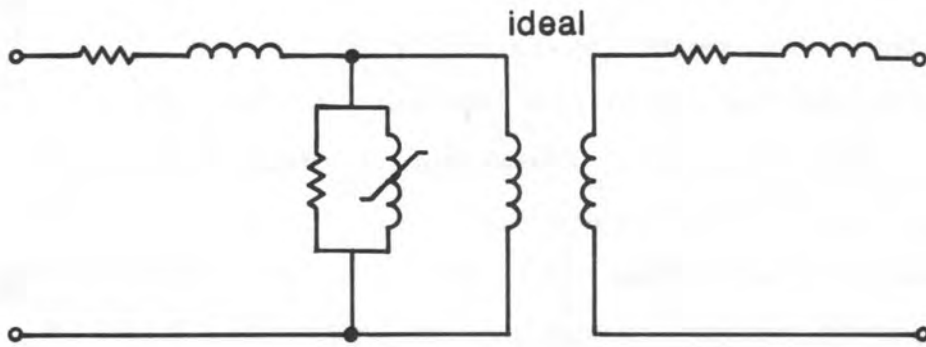

(a) Ideal transformer plus equivalent circuit model.

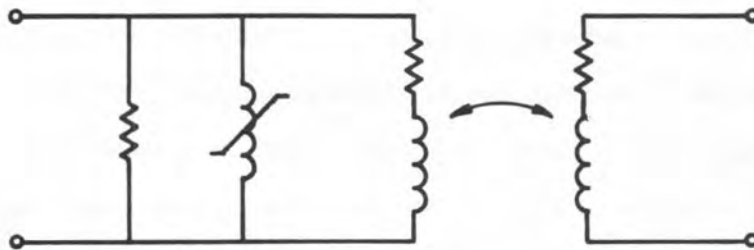

(b) Mutual coupled inductances.

Figure 15.1: Representations of a two winding transformer for slow transients.

Implementing the transformer models in the EMTF

There are three ways of representing transformers in the EMTF. We will only learn one way here: the built-in TRANSFORMER model. This model requires as a minimum the following information:

- The voltage rating of each winding.
- The leadage impedance of each winding.
- Transformer connectivity information.

In addition, you may also have the magnetization current characteristics of the transformer, which may be nonlinear.

TRANSFORMER model require several data lines to describe. The first data line has the keyword "TRANSFORMER". It also gives the transformer a unique name. All other data fields are optional. The optional fields can be used to specify the steady state RMS magnetization flux (in volt-seconds) and current (in amps) as seen from winding #1, and the magnetization core loss resistance R_{mag} .

Following the first data line naming of the transformer are the data lines describing the saturation curve of the transformer as points in a "current" versus "flux" curve. This curve is generally not directly available, but must be calculated from given data; the next sub section explains how. The magnetization curve data is terminated with a data line with a "9999" in columns 13-16. If no magnetization branch is desired, put the 9999 data line immediately after the first transformer data line.

Following the magnetization data is the winding data. Each winding must be numbered, starting with 01. Each winding is connected to two nodes. As before, if one of the nodes is ground, the default name for ground is " " (6 spaces).

In each winding data line put the winding resistance, leakage reactance and voltage. All windings except the first are allowed to have zero impedance.

The exact format of all this information is best illustrated in the enclosed coding sheets.

Problem 15.1: Prepare the data to represent a 200 MVA 230:69 KV grounded Y to Delta transformer, $X = 10\%$.

The high side nodes are BUS12A, BUS12B and BUS12C and the low side node names are BUS13A, BUS13B and BUS13C.

```
C Transformer Data
C
C TRANSFORMER<-----><--Iss<--PhiName-><-Rmag<-----Ignore----->0
TRANSFORMER
C          .....^.....^.....^.....^          ^
C
C Saturation curve
C -----Current<-----Flux
C .....^.....^
C .....^.....^
C .....^.....^
C .....^.....^
C .....^.....^
C .....^.....^
          9999
C
C Winding Data
C
C Bus-->Bus--><--Ignore--><---R<---L<-Volt<----->0
01
C .....^.....^          .....^.....^.....^          ^
02
C .....^.....^          .....^.....^.....^          ^
03
C .....^.....^          .....^.....^.....^          ^
```

The rescaling of currents is more complicated, except for point i_B at the end of the linear region A-B:

$$i_B = I_{\text{RMS-B}}\sqrt{2}. \quad (2)$$

The following points i_C, i_D, \dots are found recursively (Figure 15.2): Assume that i_E is the next value to be found. Assume further that the sinusoidal flux just reaches the value ψ_E at its maximum,

$$\psi = \psi_E \sin \omega t. \quad (3)$$

Within each segment of the curve already defined by its end points, in this case A-B, B-C and C-D, i is known as a function of ψ (namely piecewise linear), and with (3) is then also known as a function of time. Only the last segment is undefined inasmuch as i_E is still unknown. Therefore, $i = f(t, i_E)$ in the last segment. If the integral needed for RMS-values,

$$F = \frac{2}{\pi} \int_0^{\pi/2} i^2 d(\omega t) \quad (4)$$

is evaluated segment by segment, the result will contain i_E as an unknown variable. With the trapezoidal rule of integration (reasonable step width = 1°), F has the form

$$F = a + bi_E + ci_E^2 \quad (5)$$

with a, b, c known. Since F must be equal to $I_{\text{RMS-E}}^2$ by definition, Eq. (5) can be solved for the unknown value i_E . This process is repeated recursively until the last point i_N has been found. If the ψ/i -curve thus generated is used to recompute a $V_{\text{RMS}}/I_{\text{RMS}}$ -curve it will match the original $V_{\text{RMS}}/I_{\text{RMS}}$ -curve, except for possible round-off errors.

The EMTP has a supporting program "SATURATION" to do precisely these calculations for you. The input data required is a number of RMS points for voltage values and current values at no load. The output is a printout (and a file) containing the necessary flux-current data.

The input format for the SATURATION routine is illustrated in the corresponding coding sheet. As an example consider the calculation of the flux curve for the following problem:

<u>IRMS (%)</u>	<u>VRMS(pu)</u>
.5	.9
.8	1.0
1.5	1.1
5.0	1.2
15.0	1.25

Assume that the transformer RMS voltage base is $230/\sqrt{3}$, and the power base is $200/3$. Input data for this problem is illustrated in Figure 15.3(c), and the output results are shown in Figure 15.3(b).

C Calculation of the current vs flux saturation curves from the knowledge
C of the RMS magnetization current of the transformer.

C

BEGIN NEW DATA CASE

SATURATION

C
C --Freq<-KVbase<MVAbase i_0: file output 1: no file output

C^.....^.....^ ^

C

C -----I_{rms}<-----V_{rms}

C^.....^.....^

C^.....^.....^

C^.....^.....^

C^.....^.....^

C^.....^.....^

C^.....^.....^

C^.....^.....^

C^.....^.....^

9999

BLANK End of Saturation Cases

BEGIN NEW DATA CASE

BLANK End of Run

Problem 15.2: Modify the data in Figure 15.3 so the output will be directly in KA and KV-s without further corrections needed.

Using the saturation curves

We illustrate two cases of the effect of saturation that show how to use the saturation data. The first case considers the plotting of the time-domain magnetization current as the voltage is stepped up from 0.9 pu to 1 pu to 1.1 pu to 1.2 pu every two cycles. This example serves to illustrate the shape of the time-domain magnetization current actually produced by the EMTP. Figure 15.4 illustrates this case. Notice in particular that the saturation curve from Figure 15.3(b) was converted from Amps and Volt-seconds to Kamps and KVolt-seconds. As a second example of how to use the saturation data and the effect that saturation may have on overvoltages, consider the circuit in Figure 15.5(a), the operation of line 1-12 at no load conditions using a very simple source Thevenin model. Consider the case of operation at 15% overvoltage conditions, which can easily occur in a load rejection study, that is:

$$V_{\text{Thev}} = \frac{230}{\sqrt{3}} \sqrt{2} \times 1.15 = 215.96 \text{ KV}$$

This study discusses the effect that source side resonances may have. The resonances will be more pronounced when the voltage-improving 80 MVAR capacitor bank is in service at bus 1. The capacitance of this bank is approximately 4 microfarads per phase. We will study three steady state cases. Figure 15.5(b) contains input data for the second of these cases.

- The capacitor in service, the transformer magnetization represented as a linear branch. The results are illustrated in Figure 15.5(c).
- The capacitor in service, the transformer magnetization represented as a nonlinear branch. This case is shown in Figure 15.5(d), its data in Figure 15.5(b).

- The transformer magnetization represented as a nonlinear branch, the capacitor out of service. The results are shown in Figure 15.5(e).

Observe that ignoring saturation has a pronounced effect on the voltage waveform. Also observe that the presence or absence of the capacitor influences the amount of harmonics present, even when saturation is represented.

```

BEGIN NEW DATA CASE
C =====
C
C Calculation of the current vs flux saturation curves from the knowledge
C of the RMS magnetization current of the transformer.
C
C .....
C
SATURATION
C --freq<-KVbase<MVABase<-Ipunch<-kthird
   60. 132.791  66.667    0    0
C Notice that we are working in KV not in V in the EMTP runs.
C -----Irms<-----Vrms
   0.005         0.9
   0.008         1.0
   0.015         1.1
   0.050         1.2
   0.150         1.25
   9999
BLANK End of Saturation Cases
BEGIN NEW DATA CASE
BLANK End of Run

```

(a) Input data.

```

DERIVED SATURATION CURVE GIVING PEAK CURRENT VS. FLUX
  ROW      CURRENT (AMP)      FLUX (VOLT-SEC)
  1         0.0000000000         0.0000000000
  2         3.5499911727         448.3271397706
  3         7.9501058958         498.1412664117
  4        15.9271288023         547.9553930529
  5        61.4854155098         597.7695196941
  6       219.1499933591         622.6765830147
          9999

```

(b) Portion of output results.

Figure 15.3: Calculations of saturation curves using the EMTP.

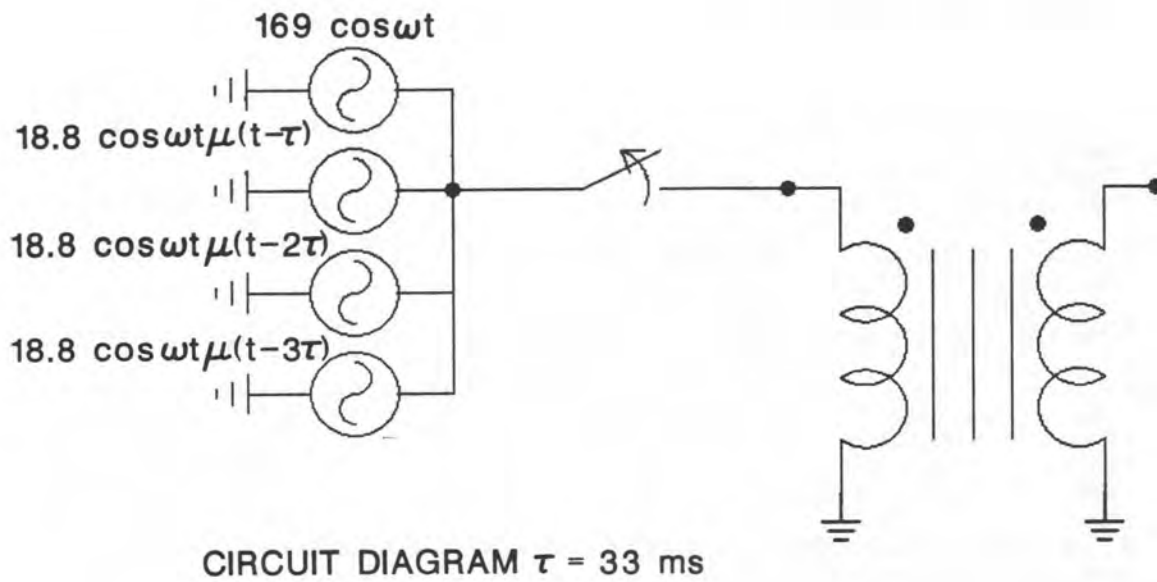

(a) Circuit diagram.

Figure 15.4: Illustration of steady state magnetization current as the voltage is stepped from .9 pu to 1.1 pu every 2 cycles. Parallel voltage sources are actually in series, by EMTP convention.



```

BEGIN NEW DATA CASE
C =====Figure 15.4(b)=====
C Testing of nonlinear transformer under ideal voltage source conditions .
C .....
C
C ----dt<---tmax
C 50.E-6 100.E-3
C
C -Iprnt<--Iplot
C 15 1
C
C .....Circuit data.....
C TRANSFORMER-ref--><----><---Iss<--PhiName-><-Rmag<-----Ignore----->0
TRANSFORMER .00355.44833XFMRA 0
.0035499911727 .4483271397705
.0079501058958 .4981412664117
.0159271288023 .5479553930520
.0614854155098 .5977695196940
.2191499933591 .6226765830146
9999 0
C Bus-->Bus--><---Ignore--><----R<----L<-Volt<-----Ignore----->0
1BKR 0. 35.08 132.8 1
2LOAD 0. 9.471 69.00 0
BLANK End of circuit data.....:
C
C .....Switch data.....
C Bus-->Bus--><---Tclose<---Topen 0
SRC BKR -1.E-3 9999. 1
BLANK End of switch data.....:
C
C .....Source data.....
C Bus--><I<Amplitude<Frequency<--T0;Phi0<---0=Phi0<-Ignore-><---Tstart<---Tstop
14SRC 169.014 60. 0. 0. -1. 0.
14SRC 18.779 60. 0. 0. .03333 0.
14SRC 18.779 60. 0. 0. .06667 0.
14SRC 18.779 60. 0. 0. .10000 0.
C peak Line to ground voltage for a 230 KV RMS line to line source is 187.79KV ;
BLANK End of source data.....:
C
C .....Output Request Data.....
C Bus-->Bus-->Bus-->Bus-->Bus-->Bus-->Bus-->Bus-->Bus-->Bus-->Bus-->
SRC BKR LOAD
BLANK End of output requests.....:
C
C Plot request Data.....
C 2Illustration of magnetization current as voltage increases
C ----Graph type: 4(volts) 8(branch volts) 9(currents) .
C : ----Units: 1(deg) 2(cyc) 3(sec) 4(msec) 5(microsec) .
C :: ----Units per inch .
C :: : ----Plot starting time .
C :: : : ----Plot stopping time .
C :: : : .
C VV<-:<--:<--: Bus-->Bus-->Bus-->Bus-->Heading----->Vert axis----->
19410. 0.0100. SRC BKR ImagTrivial Bkr KA
BLANK End of Plot Request.....:
BEGIN NEW DATA CASE
BLANK End of data

```

(b) Input data.

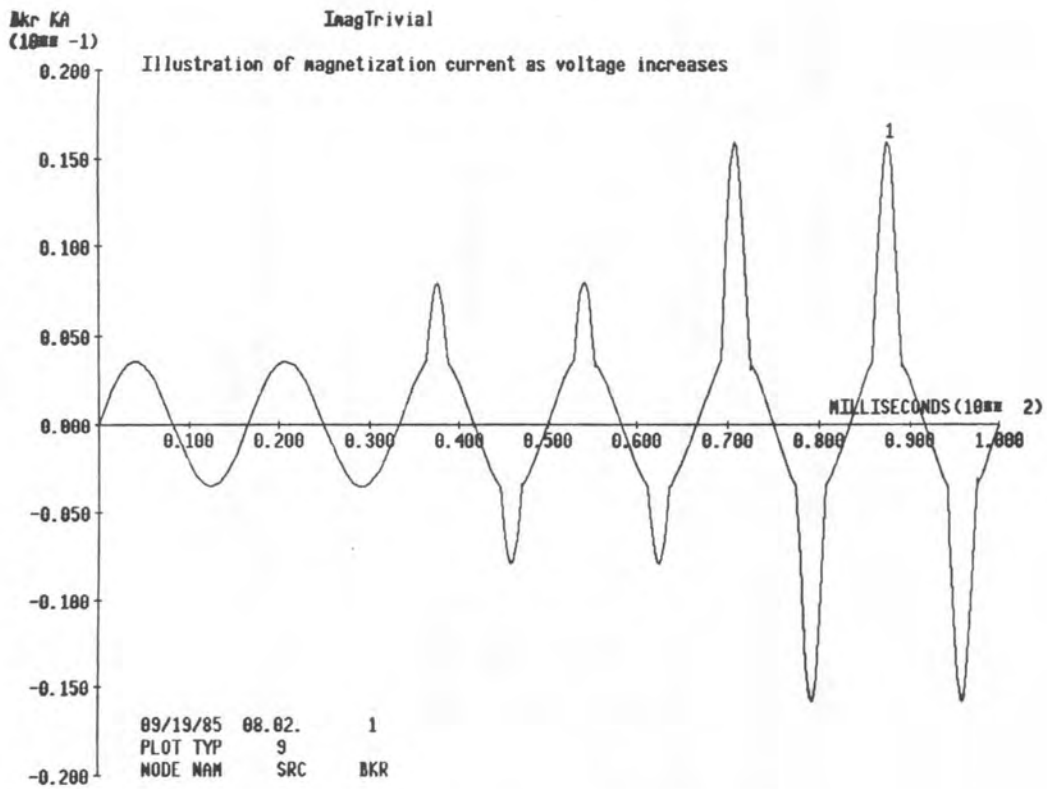
Figure 15.4: (continued).



(c) Magnetization current.

Figure 15.4: (continued).

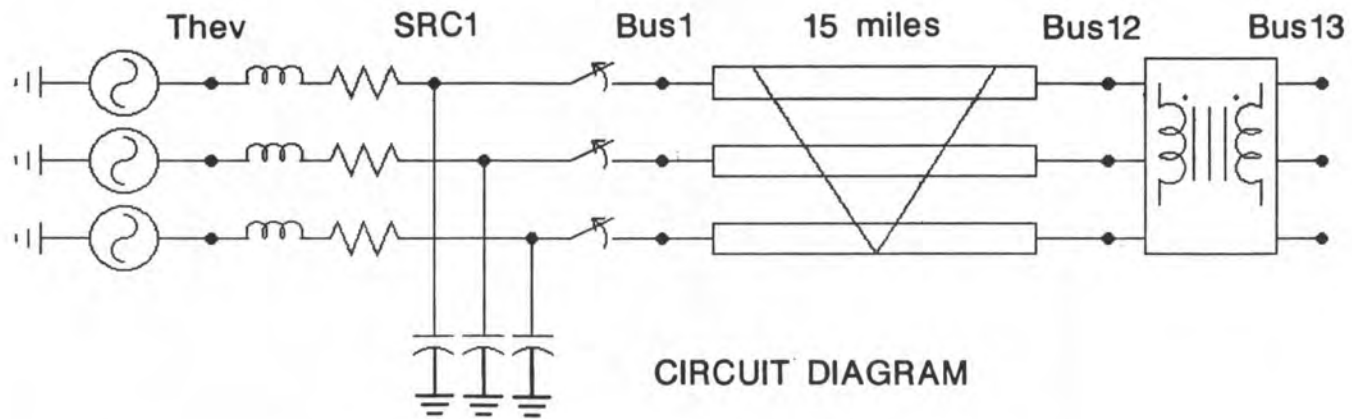

(a) Circuit diagram.

Figure 15.5: Effect of saturation and nonlinearities on voltage waveforms.

```

BEGIN NEW DATA CASE
C -----Figure 15.5(b)-----
C Energization of line 1-12 with a nonlinear transformer, no load, 15% OV .
C capacitor at bus 1. Resonance at 5th harmonic occurs.
C ----->
C -dt<---tmax<
20.E-6 40.E-3
C -Iprnt<--Iplot<-Idoubl<-KssOut<-MaxOut <---Icat
15 1 0 0 0 0
C
C .....Circuit data.....
C Bus-->Bus-->Bus-->Bus--><---R<---L<---C 0
THEVA SRC1A 0.714 70.68 0
THEVB SRC1B THEVA SRC1A 0
THEVC SRC1C THEVA SRC1A 0
SRC1A 4.00 0
SRC1B SRC1A 0
SRC1C SRC1A 0
C Bus-->Bus-->Bus-->Bus--><---R'<---L'<---C'<---len 0 0 0 0
-1BUS1A BUS12A 0.3167 3.222.00787 24.14 0 0 0
-2BUS1B BUS12B 0.0243 .9238 .0126 24.14 0 0 0
-3BUS1C BUS12C 0
C
C TRANSFORMER-ref--><---><---Iss<---PhiName-><-Rmag 0
TRANSFORMER .00355.44833XFMRA 0
.0035499911727 .4483271397705 0
.0079501058958 .4981412664117 0
.0159271288023 .5479553930520 0
.0614854155098 .5977695196940 0
.2191499933591 .6226765830146 0
9999 0
C Bus-->Bus--><---Ignore--><---R<---L<-Volt 0
1BUS12A 0. 35.08 132.8 1
2BUS13ABUS13B 0. 9.471 69.00 0
C
C TRANSFORMER-ref--><---><---Iss<---PhiName-><-Rmag 0
TRANSFORMER XFMRA XFMRB 0
1BUS12B 1
2BUS13BBUS13C 0
C
C TRANSFORMER-ref--><---><---Iss<---PhiName-><-Rmag 0
TRANSFORMER XFMRA XFMRB 0
1BUS12C 1
2BUS13CBUS13A 0
BLANK End of circuit data.....!
C
C .....Switch data.....
C Bus-->Bus--><---Tclose<---Topen<-----Ie 0
SRC1A BUS1A -1.E-3 9999. 0 1
SRC1B BUS1B -1.E-3 9999. 0 1
SRC1C BUS1C -1.E-3 9999. 0 1
BLANK End of switch data.....!
C
C .....Source data.....
C Bus--><I<Amplitude<Frequency<---T0:Phi0<---0=Phi0 <---Tstart<---Tstop
14THEVA 215.963 60. 0. 0. -1. 9999.
14THEVB 215.963 60. -120. 0. -1. 9999.
14THEVC 215.963 60. 120. 0. -1. 9999.
BLANK End of source data.....!

```

(b) Input data.

Figure 15.5: (continued).

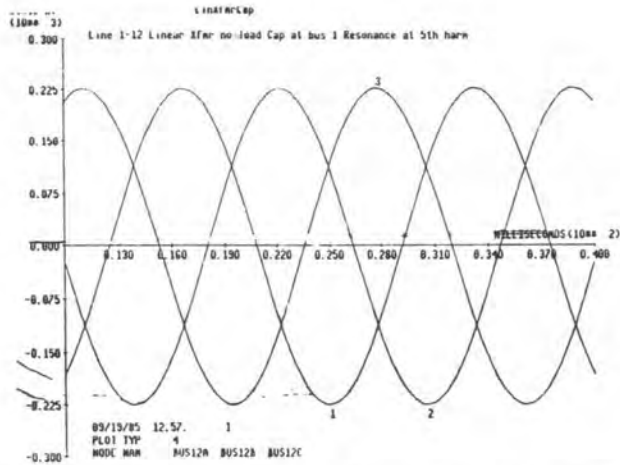

(c) Capacitor at bus 1, linear transformer.

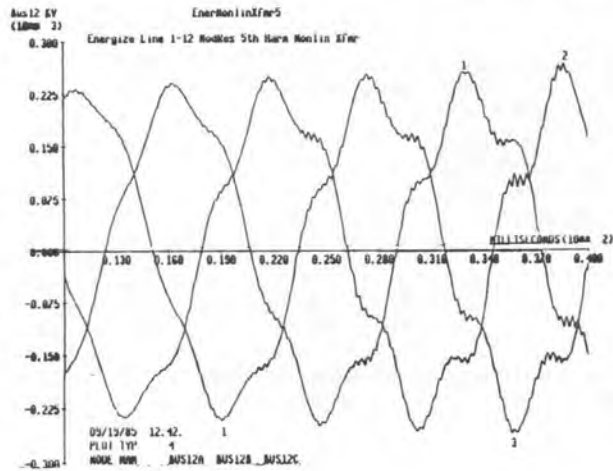

(d) Capacitor at bus 1, nonlinear transformer.

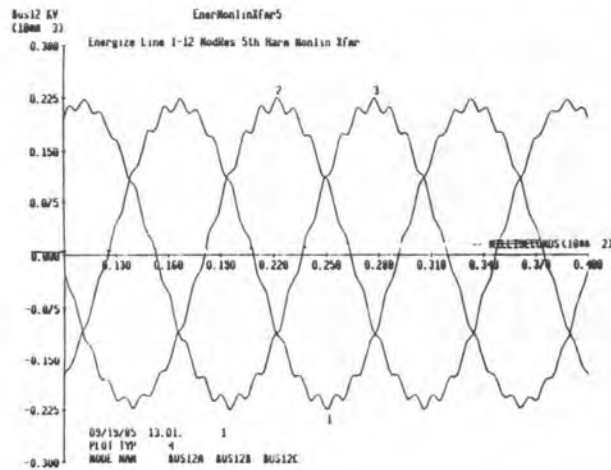

(e) No capacitor at bus 1, nonlinear transformer.

Figure 15.5: (continued).

```

C True Nonlinear Inductance Model =====
C
C Bus-->Bus-->Bus-->Bus--><--Iss<Phiss                                O
93
C .....^.....^.....^.....^.....^.....^.....^                                ^
C
C -----Current<-----Flux
C .....^.....^.....^.....^.....^.....^.....^
C .....^.....^.....^.....^.....^.....^.....^
C .....^.....^.....^.....^.....^.....^.....^
C .....^.....^.....^.....^.....^.....^.....^
C .....^.....^.....^.....^.....^.....^.....^
C .....^.....^.....^.....^.....^.....^.....^
C .....^.....^.....^.....^.....^.....^.....^
C .....^.....^.....^.....^.....^.....^.....^
C .....^.....^.....^.....^.....^.....^.....^
C .....^.....^.....^.....^.....^.....^.....^
C .....^.....^.....^.....^.....^.....^.....^
C .....^.....^.....^.....^.....^.....^.....^
C .....^.....^.....^.....^.....^.....^.....^
C .....^.....^.....^.....^.....^.....^.....^
C Termination Code
C                               9999.
C

```

Off-Site Records Management, LLC



F0001883408

Container #: 1037172

ACCT: EP2465
POD

EPRI EL-4651 Vol.1



Members of the EMTP Development Coordination Group

Bonneville Power Administration

Canadian Electrical Association-Utility Members

Hydro Quebec

Ontario Hydro

Western Area Power Administration

United States Bureau of Reclamation

Associate Members of the EMTP Development Coordination Group

ASEA

Central Research Institute
of the Electric Power Industry in Japan
